

# XBS-C / XBSS-C Flexible Coupling - Single - Disk Type

WEB Selection Tool   WEB CAD Download   Zero Backlash   High Rigidity   SUS Stainless steel

**XBS-C** Aluminum alloy hub  
**XBSS-C** Made of all stainless steel

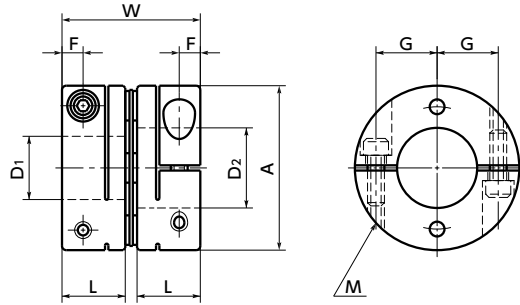

## Dimensions

Unit : mm

Part Number	A	L	W	F	G	M	Screw Tightening Torque (N·m)
XBS-15C2	15	7.5	16	2.3	5.25	M2	0.5
XBS-19C2	19	9	19	2.5	7.1	M2	0.5
XBS-25C2	25	11	23.6	3.5	9.25	M2.5	1
XBS-27C2	27	11	23.6	3.5	10.25	M2.5	1
XBS-34C3	34	12	26.2	4	13	M3	1.5
XBS-39C2	39	15	32.8	5	14.5	M4	3.5
XBS-44C2	44	15	32.8	5	17	M4	3.5
XBS-56C3	56	20	43.2	6	21.25	M5	8
XBS-68C5	68	24	53	7	25	M6	13
XBS-82C5	82	31	68	9	29.5	M8	30
XBS-94C7	94	31	68.8	9	35.5	M8	30
XBS-104C8	104	32	71.2	9	40.5	M8	30
XBSS-15C2	15	7.5	16	2.3	5.25	M2	0.5
XBSS-19C2	19	9	19	2.5	7.1	M2	0.5
XBSS-25C2	25	11	23.6	3.5	9.25	M2.5	1
XBSS-27C2	27	11	23.6	3.5	10.25	M2.5	1
XBSS-34C3	34	12	26.2	4	13	M3	1.5
XBSS-39C2	39	15	32.8	5	14.5	M4	3.5
XBSS-44C2	44	15	32.8	5	17	M4	3.5
XBSS-56C3	56	20	43.2	6	21.25	M5	8

size	Standard Bore Diameter																											
	D1	D2	3	4	5	6	8	10	11	12	14	15	16	18	19	20	22	24	25	28	30	32	35	38	40	42	45	50
15C2	●	●	●	●																								
19C2		●	●	●	●																							
25C2			●	●	●	●																						
27C2				●	●	●	●	●																				
34C3					●	●	●	●	●																			
39C2						●	●	●	●	●																		
44C2							●	●	●	●	●																	
56C3								●	●	●	●	●																
68C5*1										●	●	●	●															
82C5*1											●	●	●	●	●													
94C7*1												●	●	●	●	●	●											
104C8*1													●	●	●	●	●	●	●									

- All products are provided with hex socket head cap screw.
- Recommended dimensional allowances of applicable shaft diameter are h6 and h7.
- In case of mounting on D-cut shaft, be careful about the position of the D-cut surface of the shaft. → P.257
- \*1 This size is only for **XBS-C**.

Additional Keyway at Shaft Hole → P.788   Cleanroom Wash & Packaging → P.792   Change to Stainless Steel Screw → P.790  
 Available / Add'l charge   Available / Add'l charge   Available / Add'l charge

## Performance

Part Number	Max. Bore Diameter (mm)	Rated*1 torque (N·m)	Max.*1 torque (N·m)	Max. Rotational Frequency (min <sup>-1</sup> )	Moment*2 of Inertia (kg·m <sup>2</sup> )	Static Torsional Stiffness (N·m/rad)	Max. Lateral Misalignment (mm)	Max. Angular Misalignment (°)	Max. Axial Misalignment (mm)	Mass*2 (g)
XBS-15C2	6	0.6	1.2	42000	9.8×10 <sup>-8</sup>	300	0.02	0.5	±0.1	5
XBS-19C2	8	1	2	33000	2.9×10 <sup>-7</sup>	600	0.02	1	±0.1	9
XBS-25C2	12	2	4	25000	1.1×10 <sup>-6</sup>	1300	0.02	1	±0.2	17
XBS-27C2	14	2.2	4.4	23000	1.4×10 <sup>-6</sup>	1600	0.02	1	±0.2	21
XBS-34C3	16	4.2	8.4	18000	4.0×10 <sup>-6</sup>	2500	0.02	1	±0.3	43
XBS-39C2	20	8	16	16000	9.8×10 <sup>-6</sup>	4600	0.02	1	±0.3	83
XBS-44C2	22	10	20	14000	1.6×10 <sup>-5</sup>	6000	0.02	1	±0.3	105
XBS-56C3	28	25	50	11000	5.7×10 <sup>-5</sup>	14000	0.02	1	±0.4	232
XBS-68C5	32	60	120	9000	1.6×10 <sup>-4</sup>	25000	0.02	1	±0.5	388
XBS-82C5	35	80	160	7000	4.2×10 <sup>-4</sup>	42000	0.02	1	±0.6	740
XBS-94C7	45	150	300	6000	6.9×10 <sup>-4</sup>	55000	0.02	1	±0.7	960
XBS-104C8	50	200	400	6000	1.1×10 <sup>-3</sup>	68000	0.02	1	±0.7	1180
XBSS-15C2	6	0.5	1	42000	2.3×10 <sup>-7</sup>	500	0.02	0.5	±0.1	15
XBSS-19C2	8	1	2	33000	7.4×10 <sup>-7</sup>	1000	0.02	1	±0.1	29
XBSS-25C2	12	1.2	2.4	25000	2.8×10 <sup>-6</sup>	1500	0.02	1	±0.2	53
XBSS-27C2	14	1.5	3	23000	3.8×10 <sup>-6</sup>	2100	0.02	1	±0.2	67
XBSS-34C3	16	3.5	7	18000	1.1×10 <sup>-5</sup>	3800	0.02	1	±0.3	115
XBSS-39C2	20	5	10	16000	2.3×10 <sup>-5</sup>	5500	0.02	1	±0.3	185
XBSS-44C2	22	7	14	14000	3.9×10 <sup>-5</sup>	7000	0.02	1	±0.3	305
XBSS-56C3	28	15	30	11000	1.4×10 <sup>-4</sup>	15000	0.02	1	±0.4	610

\*1 Correction of rated torque and max. torque due to load fluctuation is not required.  
 \*2 These are values with max. bore diameter.

High-torque specification **XHS** is available. → P.74

Rated output (W)	Servomotor type				Servomotor Specifications			Selection size	
	Mitsubishi Electric Corporation	YASKAWA Electric Corporation	SANYO DENKI Co., Ltd.	KEYENCE CORPORATION	Diameter of motor shaft (mm)	Rated torque (N·m)	Instantaneous maximum torque (N·m)	XHS-C	XBS-C
100					8	0.32	1.1	XHS-19C	XBS-25C
200					14	0.64	2.2	XHS-27C	XBS-34C
400	HG-KR	SGMJV	R2	SV	14	1.3	4.5	XHS-34C	XBS-39C
750					16 - 19	2.4	8.4	XHS-39C	XBS-44C

• Part number specification

**XBS-39C2-12-14**

