

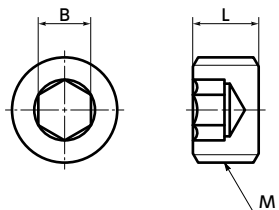

SFP Hex Socket Head Parallel Screw Plugs

[WEB Selection Tool](#)
[WEB CAD Download](#)

- For applications such as compression spring holders and oil injection opening covers.

● Application

Spring holders and load adjusters, Hydraulic equipment, pneumatic machinery and equipment, and general industrial machines

● Material/Finish

RoHS Compliant

SFP	
Main Body	S45C (Hardness 34 - 43 HRC) Ferrosoferric Oxide Coating (Black)

Unit : mm

Part Number	M	L	B	Mass (g)	Qty per pack*1
SFP-M12	M12×1.5	10	6	5	10
SFP-M14	M14×1.5	10	6	8	10
SFP-M16	M16×1.5	10	8	10	10
SFP-M18	M18×1.5	10	10	12	5
SFP-M20	M20×1.5	12	10	20	5
SFP-M22	M22×1.5	12	12	23	5
SFP-M24	M24×1.5	12	14	27	5
SFP-M27	M27×1.5	12	14	37	5
SFP-M30	M30×1.5	12	17	44	5
SFP-M33	M33×1.5	12	17	55	5
SFP-M36	M36×1.5	18	17	107	1

*1 The minimum order quantity is 1 piece. → P.794

- Usage example
Compression Spring Holder

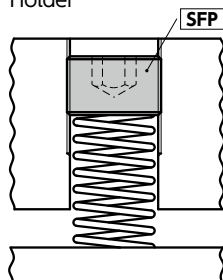

- Usage example
Protection for Unused Screw Holes

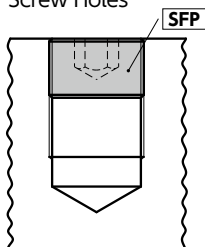

- Usage example
Oil Injection Opening Cover in Gear Boxes, Etc.

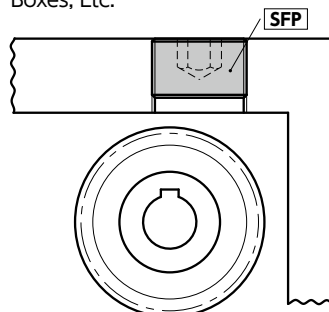

- Part number specification

SFP-M16



Order in number of packs.
The minimum order quantity is 1 piece. → P.794

Individual Sales → P.794	Cleanroom Wash & Packaging → P.792	Screw Length Adjustment → P.796	Vibration Resistant → P.795	Modification process for captive use → P.791
Available / Add'l charge	Not Available	Not Available	Please feel free to contact us	Not Available