

# AIR-PILOTED VALVES SERIES INDEX

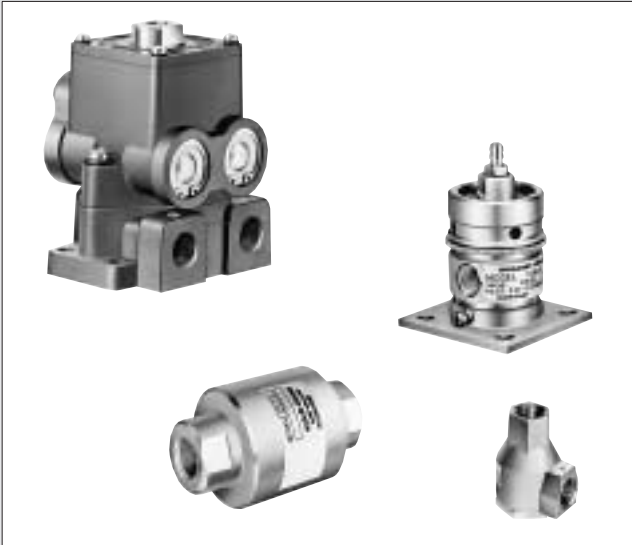

Air-piloted Valves Features	939
Application Examples of Air-piloted Valves	939
Charts for Selection of Air-piloted Valves	940
Differences between A Type and AA Type Air-piloted Valves	940
Safety Precautions	940
Diaphragm Type 125, 250, 2503, 500 Series	941
Piston Poppet Type 375, 501, 750, 1000, 1250 Series	943
Diaphragm Type 250-4, 2503-4 Series	945
Piston Poppet Type 254 Series	947
Piston Poppet Type Manifold M254 Series	949
Piston Poppet Type 375-4, 501-4, 750-4, 1000-4, 1250-4 Series	950
Double Pilot Type 125A2, 250A2, 2503A2 Series	952
Low Pressure Air-piloted Valves 125LA	954

# Air-piloted Valves Features

- Since the unit requires air piping only, with no need for electrical wiring, it can be handled by a person without fear of electrical shocks or current leakage.
- Using no electricity means that expensive equipment to protect against explosions, special precautions, or measures against electric noise are not to be required.
- Unlike electrical equipment, the construction is simple. The associated limit valve is also durable and can be used for long periods.
- Because harmless compressed air is used, there is no need for major construction work on the main or pilot air line unlike that of hydraulic piping, and piping work is simple enough for anyone trained to perform.
- The power source is always compressed air, so that the system can be easily used where no power supply exists. In addition, it retains memory for about several dozen minutes, and can therefore continue operations even during power outages.

## Koganei Air-piloted Valves Features

### Assured operation

Sharp, switching characterized by poppet and diaphragm construction. The valve seat is also reliable. (Quick switching of main pressure helps to keep valve seat seal performance.)

### Few breakdowns occur in this construction.

The construction is extremely simple. A poppet valve prevents galling or other problems, even if small foreign objects have entered inside. And no sticking occurs even if the unit is left unused for long periods of time.

### It can be used without lubrication.

With virtually no sliding parts, there is no need for lubrication other than for a few specific models. This means no breakdown due to insufficient lubrication.

### Tolerates frequent operations for long operating life

The small mass and stroke of the moving parts means a small inertial force which, along with construction with the large-capacity synthetic rubber for absorbing impacts, ensures continuous high-frequency operations and a long operating life.

### Any mounting direction acceptable

No matter what direction is used for mounting, the construction causes no trouble to the operation.

### Compact and lightweight

A unique, compact design, with a body of light aluminum alloy.

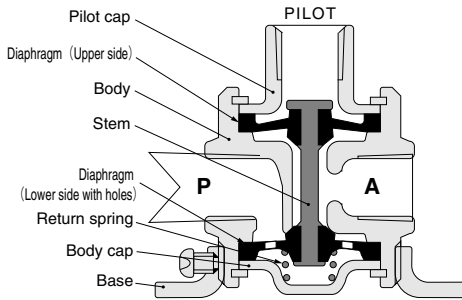

Diaphragm type basic construction (125A type)

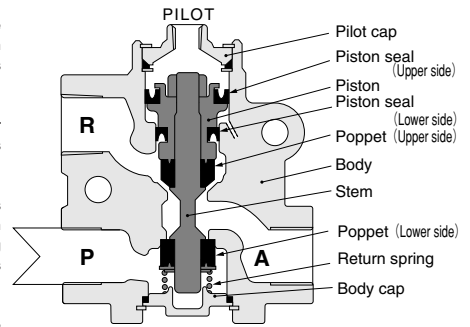

Piston poppet-type basic construction (501A type)

# Application Examples of Air-piloted Valves

## Using as a large-sized stop valve

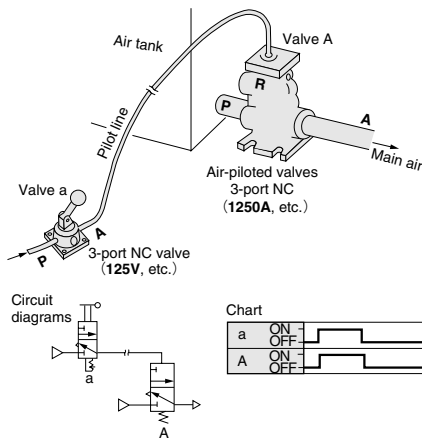

## Air cylinder operation

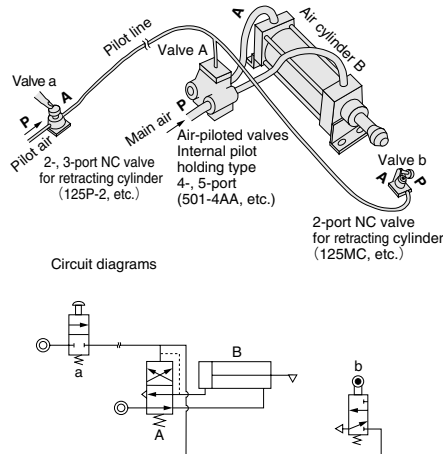

## Switching of air pressure signal

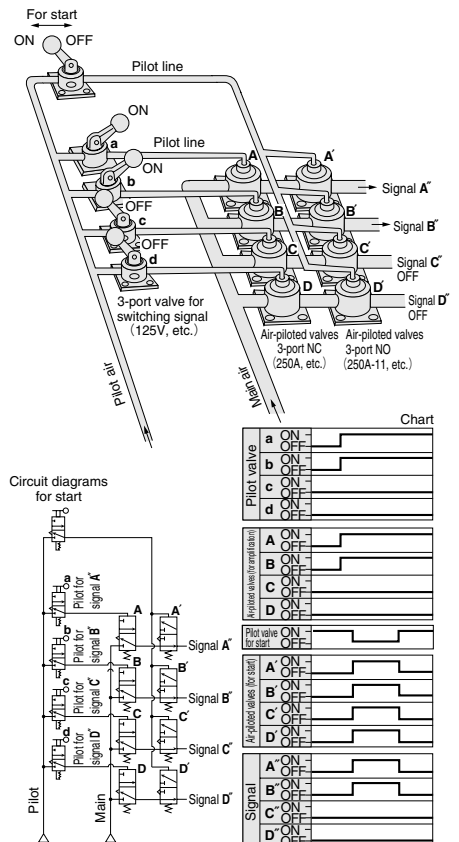

## Air cylinder operation

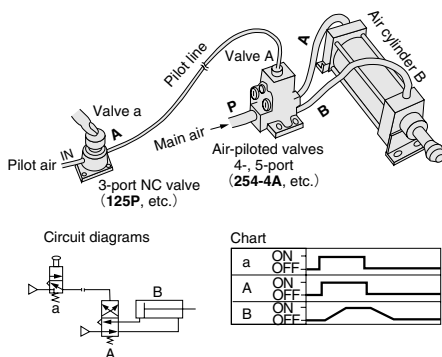

The air cylinder rod extends only as long as pilot valve **a** is pressed down.

Momentarily push pilot valve **a** to switch air-piloted valve **A**, and then maintain that condition. After switching **A**, let the air cylinder rod extend, and then push down limit valve **b**. Pushing **b** exhausts air from the **A** pilot line, switches off air-piloted valve **A**, and the air cylinder rod retracts.

To obtain signals **A'** and **B'**, turn ON hand operated valves **a** and **b**, and open the air-piloted valves **A** and **B**. Then, turning off the manual valve for start (which is normally left ON) turns off all of the air-piloted valves, (NO valves) **A'**, **B'**, **C'**, and **D'**, and opens them up, and signals **A'** and **B'** appear.

# Charts for Selection of Air-piloted Valves

## ● 2-, 3-port valve (air flow rate of each model)

Model of air-piloted valve	Air flow rate ℓ /min [ft. <sup>3</sup> /min.] (Supply pressure 0.5MPa [73psi.] when outlet port vents to the air)							
	200	300	400	1000	2000	3000	10000	20000
3P+34A (TAC valve)	120 [4.2]							
31P+341A (TAC <sup>2</sup> valve)	370 [13.1]							
125A	370 [13.1]							
250A 2503A	1000 [35.3]							
500A	3700 [131]							
375A 501A	4700 [166]							
750A	9300 [328]							
1000A 1250A	18600 [657]							

## ● 4-, 5-port valve (applicable cylinder bore size of each model)

Model of air-piloted valve	Cylinder bore size mm [in.]									
	φ20 [0.787]	25.32 [0.984] 1.260	40 [1.575]	50 [1.969]	63 [2.480]	80 [3.150]	100 [3.937]	125 [4.921]	140 [5.512]	180 [7.087]
4P+34A (TAC valve)	This area presents high cylinder speed is not required.									
41P+341A (TAC <sup>2</sup> valve)	Normal operating range (Cylinder speed 300~500mm/s [11.8~19.7in./sec.] /max. 200~300mm/s [7.9~11.8in./sec.] min. 50mm/s [2.0in./sec.]									
250-4A 2503-4A	This area presents high cylinder speed is required.									
254-4A										
375-4A 501-4A										
750-4A										
1000-4A 1250-4A	(Cylinder speed: min. 500~600mm/s [19.7~23.6in./sec.])									

- Notes :
- While the speeds shown in this graph assume an air supply pressure of 0.5MPa [73psi.] and a load ratio of 0, the speeds will be virtually the same in the range of 0.4~0.7MPa [58~102psi.], and up to a load ratio of about 30 %.
  - In general, select a valve with a margin of about 50 % for the required cylinder speed, and then use a speed controller to reduce the speed in operation.
  - In considering the time required for the cylinder to make one stroke, the "cylinder delay time" and "cushioning time" need to be considered alongside the "cylinder speed."

# Differences between A Type and AA Type Air-piloted Valves

## A type valves (Continuous pilot pressure is needed to maintain the operating condition.)

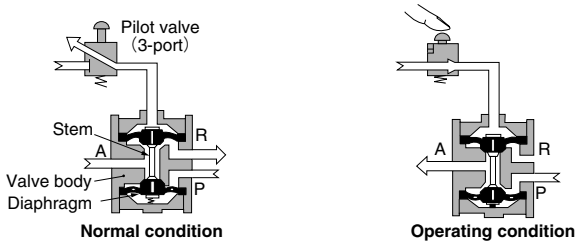

## AA type Valves (The difference from the A type valve is the existence of a bypass hole (small hole) on the stem. This helps the pilot valve to maintain its operating condition during a momentary operation. It is able to maintain the operating condition even if a certain amount of air leaks from the pilot line.)

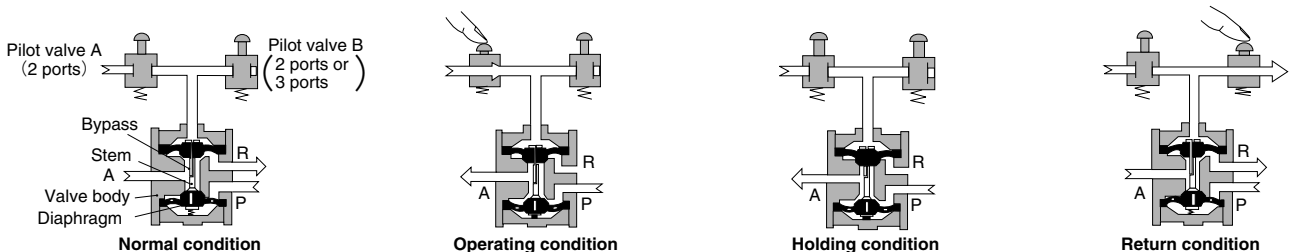

Note : These schematic diagrams show the diaphragm type, 3-port valves. The bypass for the 4-, 5-port valve is on the A side stem. See the Operating Principles for the 250-4 AA type on p.946.

## Safety Precautions (Air-piloted valves)



### Warning

- All types other than the A2 (double pilot) type are designed to use air as the media. For other media, consult us.
- Always check the Catalog, etc., when performing piping to products to ensure that the connections are correctly done. Wrong piping could result in abnormal operation of the actuator, etc.



### Caution

For locations subject to water or to large amounts of dust, use a cover, etc., to protect the valve. In addition, install a muffler, etc., to the R port to prevent entering of dust. Intrusion of water or dust could result in short-term functional breakdowns, or in sudden drops in performance or reduced operating life.



### Others

- Use main air pressure higher than the minimum operating pressure listed in the Catalog.
- Set the pilot pressure to a level suitable to the main pressure. An unnecessarily high pressure can shorten the operating life.
- If excessively throttling the R port for operation, set the pilot pressure at the main pressure or higher (A type). For details, see the specifications of each series.
- The AA type (internal pilot holding type) cannot be used as a 2-port valve. For a large air flow rate, provide sufficient air supply. In addition, the R port cannot be used in a choked condition. Install speed controllers between the valve and cylinder.
- As with the normal A type, use a pilot valve size that offers enough margin when the AA type is operated as a single pilot valve. In this case, set the main and pilot valves to the same pressure.

# Diaphragm Type Air-piloted Valves Rc1/8~1/2

125, 250, 2503, 500 Series

## Symbols

Spring return normal type (A type)				Spring return internal pilot holding type (AA type)
2-port		3-port		3-port
NC (normally closed)	NO (normally open)	NC (normally closed)	NO (normally open)	NC (normally closed)
125A-2 250A-2 2503A-2 500A-2	125A-2-11 250A-2-11 2503A-2-11 500A-2-11	125A 250A 2503A	125A-11 250A-11 2503A-11	125AA 250AA 2503AA
500A (common for NC and NO)				

## Specifications

Item	Basic model	A type (normal type)				AA type (internal pilot holding type)		
		125A	250A	2503A	500A	125AA	250AA	2503AA*
Port size Rc	Main	1/8	1/4	3/8	1/2	1/8	1/4	3/8
	Pilot	1/8				1/8		
Effective area [Cv]	mm <sup>2</sup>	5.5 [0.27]	15 [0.76]		55 [2.7]	5.5 [0.27]	15 [0.76]	
Media		Air						
Operating pressure range MPa {kgf/cm <sup>2</sup> } [psi.]	Main	Normally closed Normally closed with booster Normally open	0~0.9 {0~9.2} [0~131] 0.07~0.9 {0.7~9.2} [10~131] 0.07~0.9 {0.7~9.2} [10~131]		Normally closed 0~0.9 {0~9.2} [0~131] Normally open 0~0.5 {0~5.1} [0~73]	0.2~0.9 {2.0~9.2} [29~131]		
	Pilot	See the table "Minimum Pilot Pressure"				0.2~0.9 {2.0~9.2} [29~131] (Use at the same pressure as main pressure)		
Proof pressure MPa {kgf/cm <sup>2</sup> } [psi.]		1.35 {13.8} [196]			Normally closed 1.35 {13.8} [196] Normally open 0.75 {7.65} [109]	1.35 {13.8} [196]		
Operating temp. range (atmosphere and media) °C [°F]		5~60 [41~140]						
Maximum operating frequency Hz		10						
Lubrication		Not required						
Mass kg [lb.]		0.05 [0.11]	0.19 [0.42]	0.22 [0.49]	0.45 [0.99]	0.05 [0.11]	0.19 [0.42]	0.22 [0.49]

- Notes : 1. The AA type offers the 3-port NC (normally closed) only.  
 2. The ※ mark shows semi-standard products.  
 3. When excessively throttling the R port in operation, set the pilot pressure at the main pressure or higher.

## Operating Principles, Major Parts and Materials

### A type normally closed

#### ● Normal condition

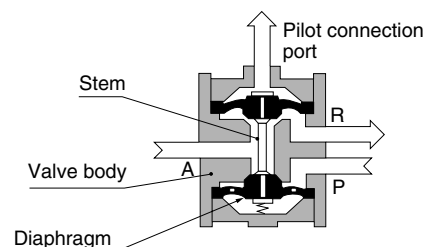

#### ● Operating condition

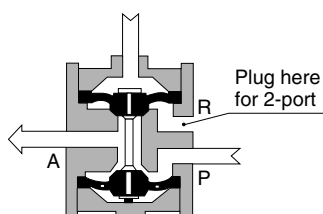

Note: The AA type (internal pilot holding type) is identical, except for the bypass hole (small hole) in the stem.

Parts	Materials
Body	Aluminum alloy (anodized)
Stem	Brass
Diaphragm	Synthetic rubber (Upper diaphragm of 500A: Urethane rubber)

## Order Codes

### ● A type (normal type)

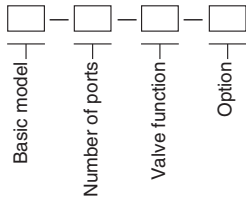

#### Basic model

Code	Main port size
125A	Rc1/8
250A	Rc1/4
2503A	Rc3/8
500A	Rc1/2

#### Valve function

Code	Valve function
Blank	NC (normally closed)
11	NO (normally open) (500A type common for NC and NO)

#### Number of ports

Code	Number of ports
Blank	3 ports
2	2 ports

#### Option

Code	specifications
22	With lock nuts for panel mounting (125A type only)
65	Normally closed with pilot booster (125A, 250A, 2503A type only)

### ● AA type (internal pilot holding type)

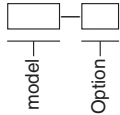

#### Basic model

Code	Main port size Rc
125AA	1/8
250AA	1/4
2503AA*	3/8

#### Option

Code	Specifications
22	With lock nuts for panel mounting (125AA type only)

Notes: 1. The \* mark shows semi-standard products.  
2. 2-port valve and normally open type not available.

## Flow Rate

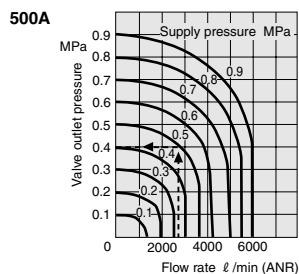
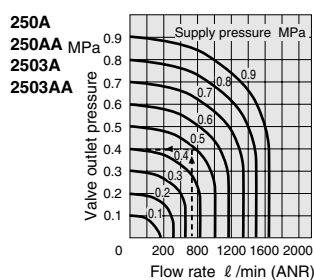
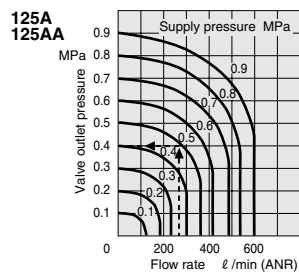

1MPa = 145psi., 1 l/min = 0.0353ft<sup>3</sup>/min.

#### How to read the graph (500A)

When the supply pressure is 0.5MPa [73psi.] and the flow rate is 2750 l/min [97.1ft<sup>3</sup>/min.] (ANR), the valve outlet pressure becomes 0.4MPa [58psi.].

## Dimensions (mm)

### ● 125A ● 125AA

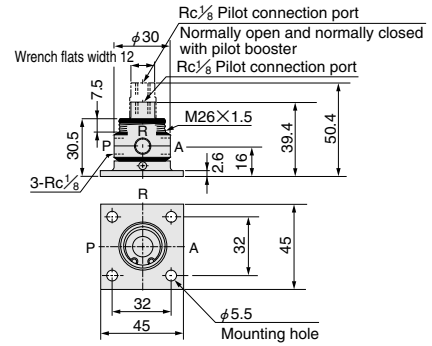

Note: For normally open type, the exhaust port (R) is on the opposite side (A type).

### ● 250A ● 250AA ● 2503A ● 2503AA

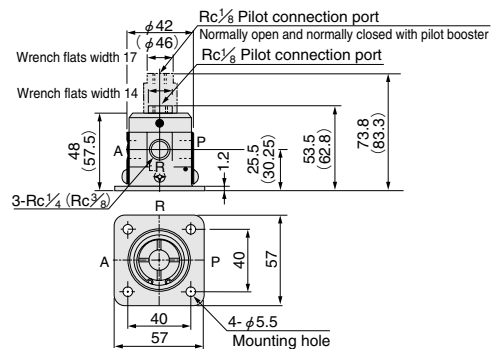

Notes: 1. ( ) shows 2503A, 2503AA  
2. For the normally open type, the exhaust port (R) is on the opposite side (A type).

### ● 500A

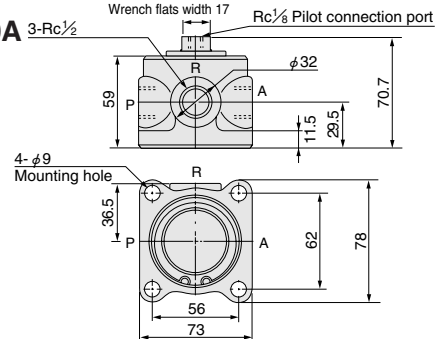

Note: For the normally open type, the exhaust port (R) becomes the inlet port (P), and P becomes R.

## Minimum Pilot Pressure

Model		MPa [psi.]							
		Main pressure							
		0	0.1	0.3	0.5	0.7	0.9		
125A	NC	0.16 [23]	0.18 [26]	0.26 [38]	0.39 [57]	0.54 [78]	0.67 [97]		
	With booster NC	—	0.13 [19]	0.2 [29]	0.26 [38]	0.35 [51]	0.44 [64]		
250A	NC	0.1 [15]	0.18 [26]	0.27 [39]	0.42 [61]	0.62 [90]	0.82 [119]		
	With booster NC	—	0.12 [17]	0.18 [26]	0.24 [35]	0.29 [42]	0.36 [52]		
2503A	NC	0.1 [15]	0.18 [26]	0.27 [39]	0.42 [61]	0.62 [90]	0.82 [119]		
	NO	—	0.15 [22]	0.24 [35]	0.34 [49]	0.45 [65]	0.57 [83]		
500A	NC	0.1 [15]	0.15 [22]	0.29 [42]	0.46 [67]	0.64 [93]	0.83 [120]		
	NO	0.12 [17]	0.18 [26]	0.35 [51]	0.55 [80]	—	—		

Note: Set the AA type pilot pressure to the same as the main pressure.

## Time Required for Switching by Pilot Line Length

(Both main and pilot 0.5MPa [73psi.]  
Pilot line inner diameter 4mm [0.16in.]  
s

Model		Pilot line length L m [ft.]					
		2 [6.6]	6 [19.7]	10 [32.8]	50 [164]	100 [328]	
125A	ON	0.05	0.1	0.2	1.0	2.6	
	OFF	0.1	0.2	0.4	1.7	4.8	
250A	ON	0.05	0.1	0.2	1.1	2.9	
	OFF	0.1	0.2	0.3	1.3	4.0	
500A	ON	0.05	0.1	0.15	1.1	3.2	
	OFF	0.1	0.1	0.2	1.2	3.0	

#### How to read the table

For example, when using a 10m [32.8ft.] pilot line to send a signal to the 125A type, it takes 0.2 second for the switching operation to turn it on and 0.4 second to turn it off.

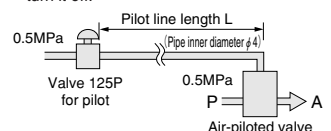

# Piston Poppet Type Air-piloted Valves Rc1/4~1 1/4

375, 501, 750, 1000, 1250 Series

## Symbols

Spring return normal type (A type)		
2-port		3-port
NC (normally closed)	NO (normally open)	NC/NO (common for NC and NO)
375A-2 501A-2 750A-2 1000A-2 1250A-2		375A 501A 750A 1000A 1250A

## Specifications

Item	Basic model	A type (normal type)				
		375A	501A	750A	1000A	1250A
Port size Rc	Main	3/8	1/2	3/4	1	1 1/4
	Pilot	1/8		1/4		
Effective area [Cv]	mm <sup>2</sup>	70 [3.5]	140 [7]	280 [14]		
Media		Air				
Operating pressure range MPa [kgf/cm <sup>2</sup> ] [psi.]	Main	0~0.9 [0~9.2] [0~131]				
	Pilot	See the table "Minimum Pilot Pressure"				
Proof pressure MPa [kgf/cm <sup>2</sup> ] [psi.]		1.35 [13.8] [196]				
Operating temp. range (atmosphere and media) °C [°F]		0~60 [32~140]				
Maximum operating frequency Hz		10	3	4		
Lubrication		Required (Turbine Oil Class 1 (ISO VG32) or equivalent)				
Mass kg [lb.]		0.6 [1.3]	1.8 [4.0]	2.7 [6.0]		

Note: When excessively throttling the R port in operation, set the pilot pressure at the main pressure or higher.

## Operating Principles, Major Parts and Materials

### ● Normal condition

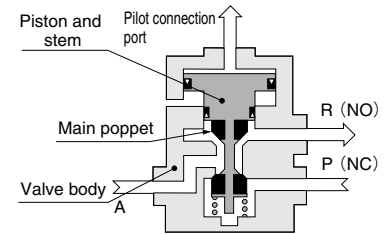

### ● Operating condition

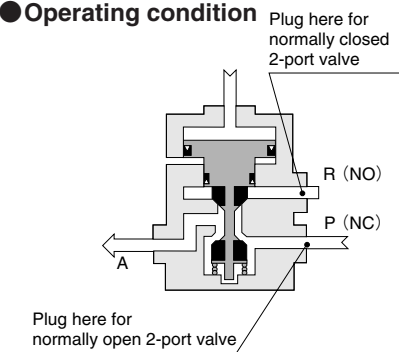

Parts	Materials
Body	Aluminum alloy (anodized)
Stem	Brass
Poppet seal	Synthetic rubber

## Order Codes

### A type (normal type)

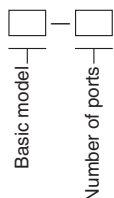

### Basic model

Code	Main port size Rc
375A	3/8
501A	1/2
750A	3/4
1000A	1
1250A	1 1/4

### Number of ports

Code	Number of ports
Blank	3 ports
2	2 ports

## Dimensions (mm)

### ● 375A ● 501A

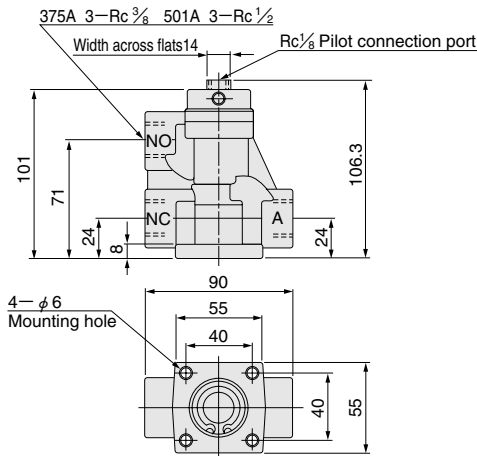

Note: For the normally closed type, the exhaust port (R) is on the NO side.  
For the normally open type, the exhaust port (R) is on the NC side. (A type only).

### ● 750A

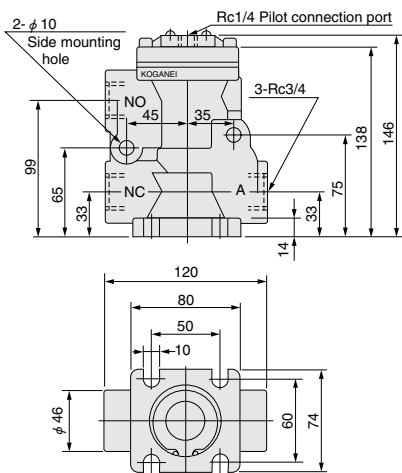

Note: For the normally closed type, the exhaust port (R) is on the NO side.  
For the normally open type, the exhaust port (R) is on the NC side. (A type only).

### ● 1000A ● 1250A

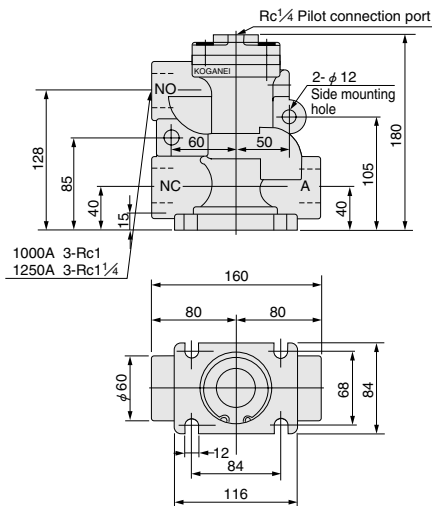

Note: For the normally closed type, the exhaust port (R) is on the NO side.  
For the normally open type, the exhaust port (R) is on the NC side. (A type only).

## Flow Rate

### 375 Series

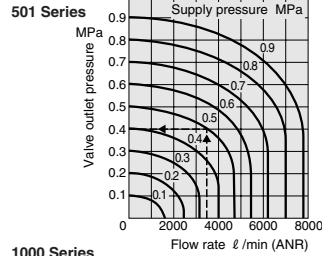

### 750 Series

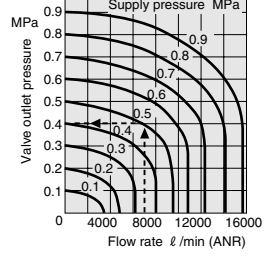

### 1000 Series

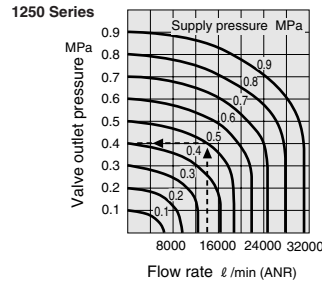

1MPa = 145psi., 1 ℓ/min = 0.0353ft<sup>3</sup>/min.

### How to read the graph (1000, 1250 series)

When the supply pressure is 0.5MPa [73psi.] and the flow rate is 13900 ℓ/min [491ft<sup>3</sup>/min.] (ANR), the valve outlet pressure becomes 0.4MPa [58psi.].

## Minimum Pilot Pressure

Model		Main pressure					
		0 [0]	0.1 [15]	0.3 [44]	0.5 [73]	0.7 [102]	0.9 [131]
375A	NC	0.1 [15]	0.1 [15]	0.22 [32]	0.33 [48]	0.45 [65]	0.57 [83]
	501A	NO	0.1 [15]	0.1 [15]	0.19 [28]	0.27 [39]	0.36 [52]
750A	NC	0.1 [15]	0.1 [15]	0.23 [33]	0.34 [49]	0.47 [68]	0.59 [86]
	1000A	NO	0.1 [15]	0.1 [15]	0.15 [22]	0.2 [29]	0.25 [36]
1250A	NC	0.1 [15]	0.1 [15]	0.2 [29]	0.29 [42]	0.39 [57]	0.49 [71]
	1250A	NO	0.1 [15]	0.1 [15]	0.15 [22]	0.2 [29]	0.25 [36]

## Time Required for Switching by Pilot Line Length

(Both main and pilot 0.5MPa [73psi.]  
Pilot line inner diameter 4mm [0.16in.] )

Model		Pilot line length L m [ft.]				
		2 [6.6]	6 [19.7]	10 [32.8]	50 [164]	100 [328]
375A	ON	0.05	0.1	0.15	1.0	2.9
	501A	OFF	0.1	0.2	0.3	1.5
750A	ON	0.05	0.15	0.2	1.2	3.0
	1000A	OFF	0.1	0.3	0.5	2.5
1250A	ON	0.09	0.15	0.2	1.3	3.7
	1250A	OFF	0.2	0.4	0.6	3.3

### How to read the table

For example, when using a 10m [32.8ft.] pilot line to send a signal to the 375A type, it takes 0.15 second for the switching operation to turn it on and 0.3 second to turn it off.

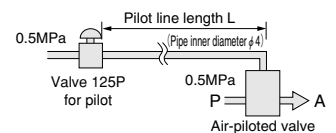



# Diaphragm Type Air-piloted Valves Rc1/4~3/8

250-4, 2503-4 Series

## Symbols

Spring return normal type (A type)	Spring return Internal pilot holding type (AA type)
5-port	
<b>250-4A</b> <b>2503-4A</b>	<b>250-4AA</b> <b>2503-4AA</b>

## Specifications

Item	Basic model	A type (normal type)		AA type (internal pilot holding type)	
		250-4A	2503-4A	250-4AA	2503-4AA
Port size Rc	Main	1/4	3/8	1/4	3/8
	Pilot	1/8			
Effective area [Cv]	mm <sup>2</sup>	15 [0.76]			
Media		Air			
Operating pressure range MPa [kgf/cm <sup>2</sup> ] [psi.]	Main	0.07~0.9 [0.7~9.2] [10~131]		0.2~0.9 [2.0~9.2] [29~131]	
	Pilot	See the table "Minimum Pilot Pressure"		0.2~0.9 [2.0~9.2] [29~131] (Use at the same pressure as the main pressure)	
Proof pressure	MPa [kgf/cm <sup>2</sup> ] [psi.]	1.35 [13.8] [196]			
Operating temp. range (atmosphere and media)	°C [°F]	5~60 [41~140]			
Maximum operating frequency	Hz	10			
Lubrication		Not required			
Mass	kg [lb.]	0.6 [1.3]			

Note: Install speed controllers between the valve and cylinder.

Do not attempt to throttle the R port, and do not install a muffler with a large exhaust resistance.

## Order Codes

Basic model		
Code	Specifications	
<b>250-4A</b>	Spring return (normal type)	Rc1/4
<b>2503-4A</b>		Rc3/8
<b>250-4AA</b>	Spring return (internal pilot holding type)	Rc1/4
<b>2503-4AA</b>		Rc3/8

## Flow Rate

250-4A  
2503-4A

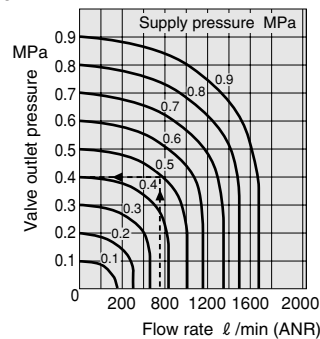

### How to read the graph

When the supply pressure is 0.5MPa [73psi.] and the flow rate is 740 l/min [26.1ft<sup>3</sup>/min.] (ANR), the valve outlet pressure becomes 0.4MPa [58psi.].

1MPa = 145psi., 1 l/min = 0.0353ft<sup>3</sup>/min.



# Operating Principles, Major Parts and Materials

## A type (normal type)

## Internal pilot holding type (AA type)

### ● Normal condition

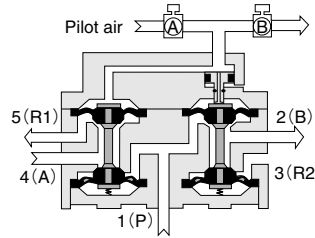
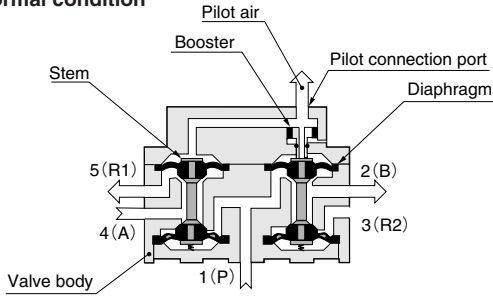

### ● Operating condition

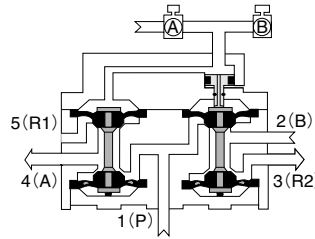
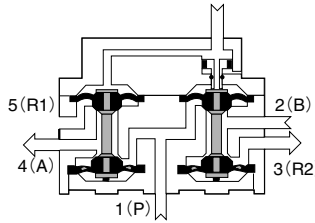

Parts	Materials
Body	Aluminum alloy (anodized)
Stem	Brass
Diaphragm	Synthetic rubber
Seal	

Note: For operation instructions, see p.940.

## Dimensions (mm)

- 250-4A
- 250-4AA
- 2503-4A
- 2503-4AA

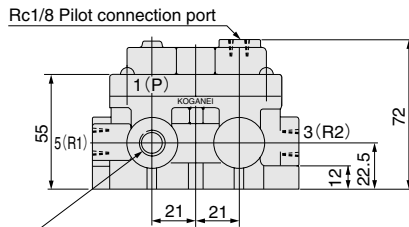

5-Rc1/4(250-4A, 250-4AA)  
5-Rc3/8(2503-4A, 2503-4AA)

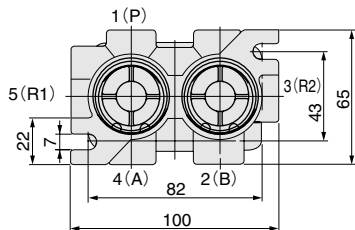

## Minimum Pilot Pressure

Model	Main pressure MPa [psi.]					
	0.07 [10]	0.1 [15]	0.3 [44]	0.5 [73]	0.7 [102]	0.9 [131]
250-4A	0.15 [22]	0.18 [26]	0.27 [39]	0.4 [44]	0.53 [77]	0.7 [102]
2503-4A						

Note: Set the AA type pilot pressure to the same as the main pressure.

## Time Required for Switching by Pilot Line Length

(Both main and pilot 0.5MPa [73psi.]  
Pilot line inner diameter 4mm [0.16in.]

Model		Pilot line length L m [ft.]				
		2 [6.6]	6 [19.7]	10 [32.8]	50 [164]	100 [328]
250-4A	ON	0.05	0.1	0.15	0.9	2.7
2503-4A	OFF	0.05	0.1	0.15	1.5	4.0

### How to read the table

For example, when using a 10m [32.8ft.] pilot line to send a signal, it takes 0.15 second for the switching operation to turn it on and 0.15 second to turn it off.

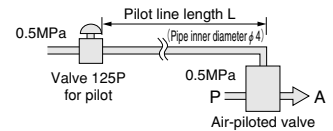

# Piston Poppet Type Air-Piloted Valves Rc1/4~3/8

254 Series

## Symbols

Spring return normal type (A type)	Spring return internal pilot holding type (AA type)
4-port	
<b>254-4A</b> 254-4A-03	<b>254-4AA</b> 254-4AA-03

## Specifications

Item	Basic model	A type (normal type)		AA type (internal pilot holding type)	
		254-4A	254-4A-03	254-4AA	254-4AA-03
Port size Rc	Main	1/4	3/8	1/4	3/8
	Pilot	1/8			
Effective area [Cv]	mm <sup>2</sup>	15 [0.76]			
Media		Air			
Operating pressure range MPa [kgf/cm <sup>2</sup> ] [psi.]	Main	0~0.9 [0~9.2] [0~131]		0.1~0.9 [1.0~9.2] [15~131]	
	Pilot	See the table "Minimum Pilot Pressure"		0.1~0.9 [1.0~9.2] [15~131] (Use at the same pressure as the main pressure)	
Proof pressure MPa [kgf/cm <sup>2</sup> ] [psi.]		1.35 [13.8] [196]			
Operating temp. range (atmosphere and media) °C [°F]		0~60 [32~140]			
Maximum operating frequency Hz		6			
Lubrication		Not required			
Mass kg [lb.]		0.8 [1.8]			

## Order Codes

### ● A type (normal type)

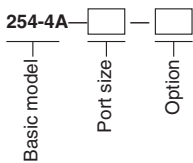

Port size

Code	Port size Rc
Blank	1/4
<b>03</b>	3/8

Option

Code	Specification
<b>70</b>	With speed controller

### ● AA type (internal pilot holding type)

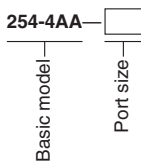

Port size

Code	Port size Rc
Blank	1/4
<b>03</b>	3/8

A built-in type speed controller cannot be installed into the 254-4AA type.  
Install a separate speed controller (KSC21, KSC31, etc.) between the valve and cylinder.

## Flow Rate

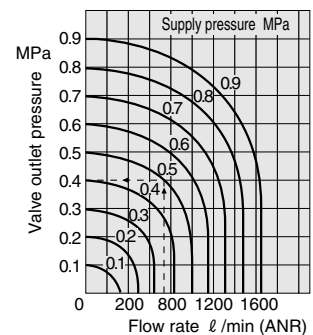

### How to read the graph

When the supply pressure is 0.5MPa [73psi.] and the flow rate is 740 l/min [26.1ft<sup>3</sup>/min.] (ANR), the valve outlet pressure becomes 0.4MPa [58psi.].

1MPa = 145psi., 1 l / min = 0.0353ft<sup>3</sup>/min.

## Operating Principles, Major Parts and Materials

### ● Normal condition

### ● Operating condition

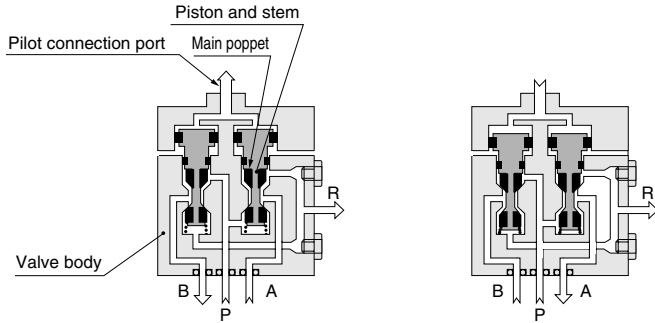

Note: The AA type (internal pilot holding type) is identical, except for the bypass hole (small hole) on the A side stem. For the operating principles and methods of use, see p.940.

Parts	Materials
Body	Aluminum alloy (anodized)
Stem	Brass
Poppet	Synthetic rubber
Seal	

## Minimum Pilot Pressure

Model	Main pressure MPa [psi.]					
	0 [0]	0.1 [15]	0.3 [44]	0.5 [73]	0.7 [102]	0.9 [131]
254-4A	0.1	0.15	0.22	0.3	0.4	0.5
254-4A-03	[15]	[22]	[32]	[44]	[58]	[73]

Note: Set the AA type pilot pressure to the same as the main pressure.

## Time Required for Switching by Pilot Line Length

(Both main and pilot 0.5MPa [73psi.]  
Pilot line inner diameter 4mm [0.16in.]

Model		Pilot line length L m [ft.]				
		2 [6.6]	6 [19.7]	10 [32.8]	50 [164]	100 [328]
254-4A	ON	0.15	0.2	0.3	1.6	3.0
	OFF	0.2	0.35	0.5	2.8	7.1

### How to read the table

For example, when using a 10m [32.8ft.] pilot line to send a signal, it takes 0.3 second for the switching operation to turn it on and 0.5 second to turn it off.

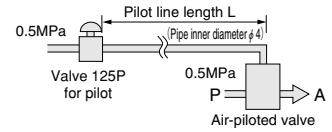

## Dimensions (mm)

### ● 254-4A

### ● 254-4AA

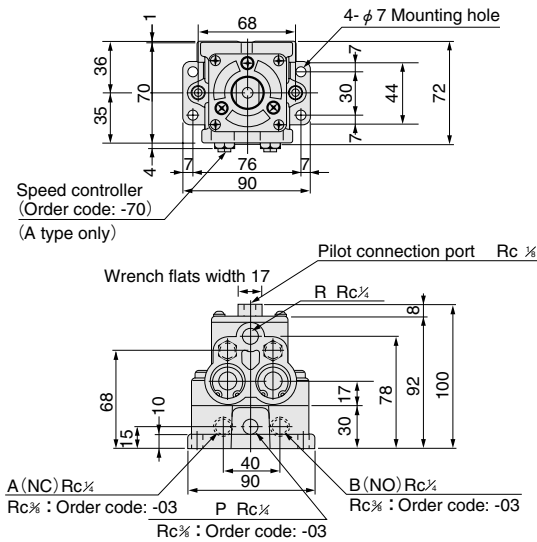

- Notes: 1. To change the speed controller installed position to the A port side, just rotate the valve body by 180 degrees. In this case, B becomes NC, while A becomes NO.  
2. A built-in speed controller cannot be installed into the 254-4AA type.

# Piston Poppet Type Rc1/4~3/8 Manifold Air-piloted Valves

## M254 Series

### Order Codes

Number of units	Stn. 1~3	M254-4A
	Stn. 4	M254-4AA
	Stn. 5	BP
	Stn. 6	M254-4E1-70-AC100V
Station		Valve model

● Number of units (number of mounting valves)	
Code	Number of units
2	2
3	3
⋮	⋮
6	6

● Station (valve mounting position)	
Code	Details
Stn.1	1st position from the left when facing the A, B ports.
Stn.2	2nd position from the left when facing the A, B ports.
Stn.3	3rd position from the left when facing the A, B ports.
⋮	⋮
Stn.6	6th position from the left when facing the A, B ports.

● Valve model	
	Model
	M 254-4A
	M 254-4AA
	M 254-4E1
	M 254-4E2
	M 254-4SE2
	Block-off plate (Order code: BP)

Enter the valve models required for each station.

- Note: 1. The prefix **M** of each valve model signifies a "solenoid valve for manifolds." Enter **M** in every order code. The order code for the valpack cylinder is **M254-4E1-70** or **M254-4A-70**.  
2. The "block-off plate" is used to close unused stations.

### Dimensions (mm)

#### Unit dimensions

Code	L
M2	175
M3	260
M4	345
M5	430
M6	515

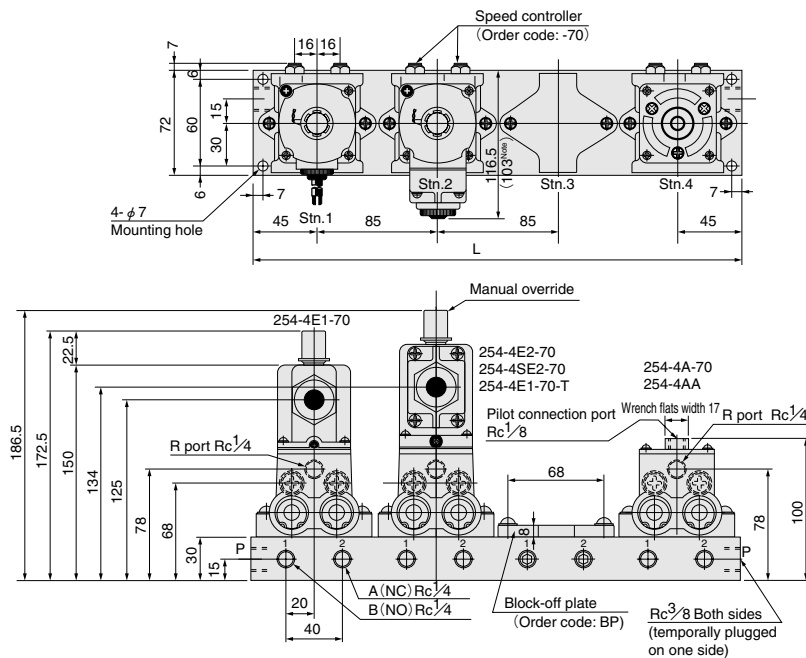

Note: Shows the 254-4E2 and 254-4E1-T dimensions.

### Manifold Mass (with valves)

Manifold model	Mounting valve model	Solenoid valve			Air-piloted valve
		Single solenoid	Double solenoid	Keep solenoid	M254-4A
		M254-4E1	M254-4E2	M254-4SE2	M254-4AA
M2		2.8 [6.2]	3.3 [7.3]	3.1 [6.8]	2.2 [4.9]
M3		4.2 [9.3]	4.9 [10.8]	4.6 [10.1]	3.3 [7.3]
M4		5.6 [12.3]	6.5 [14.3]	6.1 [13.5]	4.4 [9.7]
M5		7.0 [15.4]	8.1 [17.9]	7.6 [16.8]	5.5 [12.1]
M6		8.4 [18.5]	9.7 [21.4]	9.1 [20.1]	6.6 [14.6]
Single valve unit		0.9 [2.0]	1.2 [2.6]	1.1 [2.4]	0.6 [1.3]

### Major Parts and Materials

Parts	Materials
Base	Aluminum alloy (anodized)
Block-off plate	Aluminum alloy (anodized)

# Piston Poppet Type Air-piloted Valves Rc3/8~1 1/4

375-4, 501-4, 750-4,  
1000-4, 1250-4 Series

## Symbols

Spring return Normal type (A type)	Spring return Internal pilot holding type (AA type)
4-port	
375-4A 501-4A 750-4A 1000-4A 1250-4A	375-4AA 501-4AA

## Specifications

Item	Basic model	A type (normal type)					AA type (internal pilot holding type)	
		375-4A	501-4A	750-4A	1000-4A	1250-4A	375-4AA	501-4AA
Port size Rc	Main	3/8	1/2	3/4	1	1 1/4	3/8	1/2
	Pilot	1/8		1/4			1/8	
Effective area [Cv]	mm <sup>2</sup>	50 [2.5]		100 [5]	240 [12]		50 [2.5]	
Media		Air						
Operating pressure range MPa [kgf/cm <sup>2</sup> ] [psi.]	Main	0~0.9 {0~9.2} [0~131]					0.1~0.9 {1.0~9.2} [15~131]	
	Pilot	See the table "Minimum Pilot Pressure"					0.1~0.9 {1.0~9.2} [15~131] (Use at the same pressure as the main pressure)	
Proof pressure	MPa [kgf/cm <sup>2</sup> ] [psi.]	1.35 [13.8] [196]						
Operating temp. range (atmosphere and media)	°C [°F]	0~60 [32~140]						
Maximum operating frequency	Hz	6	3	4		6		
Lubrication		Required (Turbine Oil Class 1 (ISO VG32) or equivalent)						
Mass	kg [lb.]	0.9 [2.0]	3.4 [7.5]	4.7 [10.4]		0.9 [2.0]		

Note: When excessively throttling the R port for use, set the pilot pressure at the main pressure or higher.

## Order Codes



Basic model

Basic model		
Code	Specifications	
375-4A	Spring return (normal type)	Rc3/8
501-4A		Rc1/2
750-4A		Rc3/4
1000-4A		Rc1
1250-4A		Rc1 1/4
375-4AA	Spring return (internal pilot holding type)	Rc3/8
501-4AA		Rc1/2

## Operating Principles, Major Parts and Materials

● Normal condition

● Operating condition

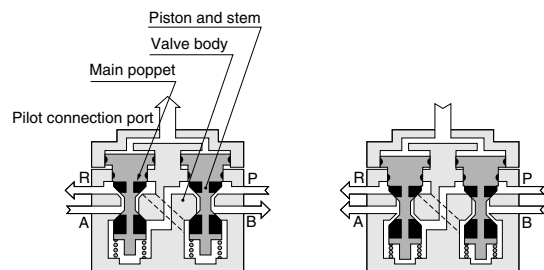

Note: The AA type (internal pilot holding type) is identical, except for the bypass hole (small hole) on the A side stem. For the operating principles and usage, see p.940.

Parts	Materials
Body	Aluminum alloy (anodized)
Stem	Brass
Poppet	Synthetic rubber
Seal	

## Dimensions (mm)

- 375-4A
- 375-4AA
- 501-4A
- 501-4AA

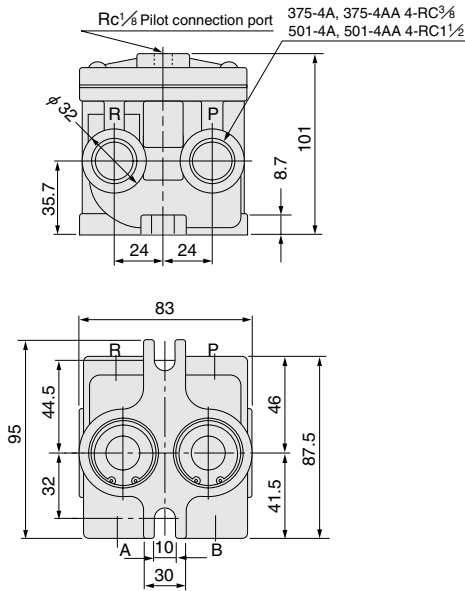

- 750-4A

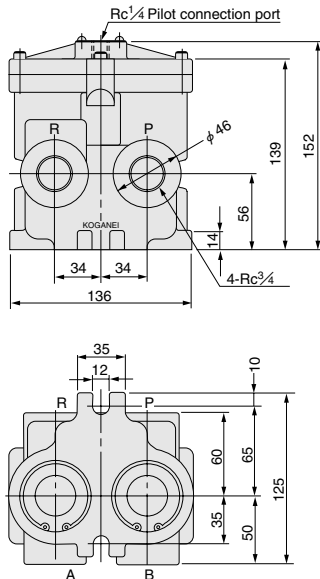

- 1000-4A
- 1250-4A

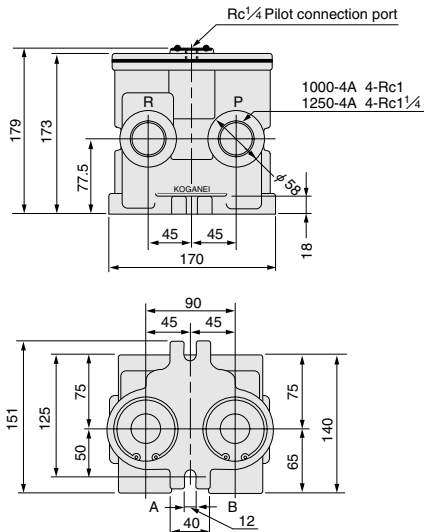

## Flow Rate

375-4 series

501-4 series

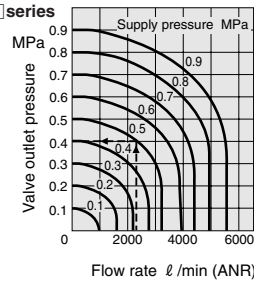

750-4 series

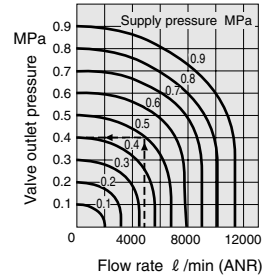

1000-4 series

1250-4 series

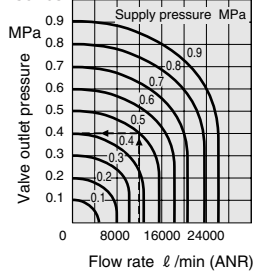

1MPa = 145psi., 1 l/min = 0.0353ft<sup>3</sup>/min.

### How to read the graph

(1000-4, 1250-4 series)  
When the supply pressure is 0.5MPa [73psi.] and the flow rate is 12000 l/min [424ft<sup>3</sup>/min.] (ANR), the valve outlet pressure becomes 0.4MPa [58psi.]

## Minimum Pilot Pressure

Model	Main pressure MPa [psi.]					
	0 [0]	0.1 [15]	0.3 [44]	0.5 [73]	0.7 [102]	0.9 [131]
375-4A						
501-4A	0.1 [15]	0.1 [15]	0.22 [32]	0.36 [52]	0.50 [73]	0.62 [90]
750-4A	0.1 [15]	0.1 [15]	0.23 [33]	0.34 [49]	0.47 [68]	0.59 [86]
1000-4A	0.1 [15]	0.1 [15]	0.21 [30]	0.31 [45]	0.42 [61]	0.53 [77]
1250-4A	0.1 [15]	0.1 [15]	0.21 [30]	0.31 [45]	0.42 [61]	0.53 [77]

Note: Set the AA type pilot pressure to the same as the main pressure.

## Time Required for Switching by Pilot Line Length

(Both main and pilot 0.5MPa [73psi.]  
Pilot line inner diameter 4mm [0.16in.]

Model		Pilot line length L m [ft.]				
		2 [6.6]	6 [19.7]	10 [32.8]	50 [164]	100 [328]
375-4A	ON	0.05	0.1	0.15	1.1	2.7
501-4A	OFF	0.1	0.15	0.2	1.7	5.0
750-4A	ON	0.05	0.15	0.2	1.2	3.0
	OFF	0.1	0.3	0.5	2.5	6.0
1000-4A	ON	0.09	0.15	0.2	1.3	3.7
1250-4A	OFF	0.2	0.4	0.6	3.3	7.5

### How to read the table

For example, when using a 10 m [32.8ft.] pilot line to send a signal to the 501-4A, it takes 0.15 second for the switching operation to turn it on and 0.2 second to turn it off.

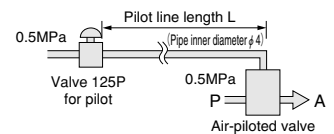

# Double Pilot Type Air-piloted Valves Rc1/8~3/8

125A2, 250A2, 2503A2 Series

## Symbols

2-port		3-port	
NC/NO (common for NC and NO)			
125A2-2 250A2-2 2503A2-2		125A2 250A2 2503A2	

## Specifications

Item		Basic model	125A2	250A2	2503A2
Port size	Rc	Main	1/8	1/4	3/8
		Pilot	1/8		
Effective area [Cv]	mm <sup>2</sup>		5.5 [0.27]	15 [0.76]	
Media			Air, Gas, Liquid, Vacuum		
Operating pressure range MPa [kgf/cm <sup>2</sup> ] [psi.]	Main	Gas	0~0.9 {0~9.2} [0~131] Vacuum 0~-100kPa [0~-29.53in.Hg]		
		Liquid	0~0.2 {0~2.0} [0~29]		
	Pilot		See the table "Minimum Pilot Pressure"		
Proof pressure	MPa [kgf/cm <sup>2</sup> ] [psi.]		1.35 {13.8} [196]		
Operating temp. range (atmosphere and media)	°C [°F]		5~60 [41~140]		
Maximum operating frequency	Hz		10		
Lubrication			Not required		
Mass	kg [lb.]		0.05 [0.11]	0.21 [0.46]	0.24 [0.53]

Note: The even larger size Rc1/2, 3/4, 1, and 1 1/4 units are available as special orders.

## Operating Principles, Major Parts and Materials

### ● Normal condition

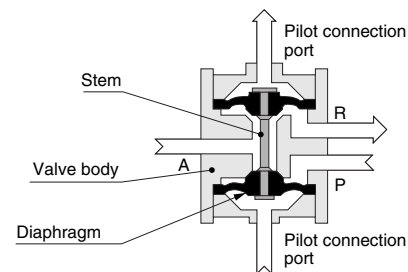

### ● Operating condition

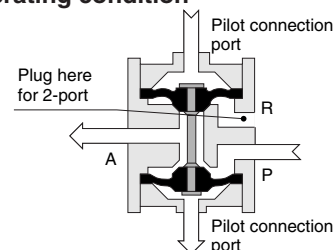

Parts	Materials
Body	Aluminum alloy (anodized)
Stem	Brass
Diaphragm	Synthetic rubber

## Order Codes

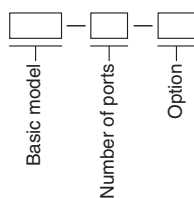

### Basic model

Code	Main port size Rc
125A2	1/8
250A2	1/4
2503A2	3/8

### Number of ports

Code	Number of ports
Blank	3 ports
2	2 ports

### Option

Code	Specifications
22	With lock nuts for mounting panel (125A2 only)

## Handling Precautions

Cannot be used with media that can damage rubber or other body materials.

For use of special media, consult us.

The standard material for the diaphragm is NBR, while that for the body is aluminum, and for the stem is brass. However, Viton can also be ordered for the diaphragm, and stainless steel for the main body and stem.

The valve cannot hold either the actuated or unactuated condition on its own.

Maintain a continuous supply of pilot air.

The pilot pressure might be slightly higher for liquid media.



## Dimensions (mm)

### 125A2

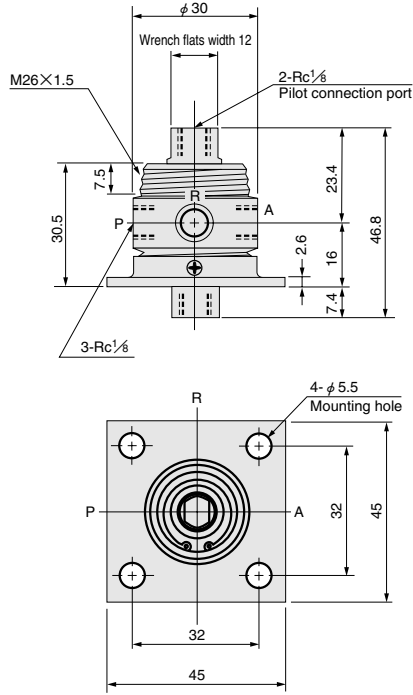

### 250A2 2503A2

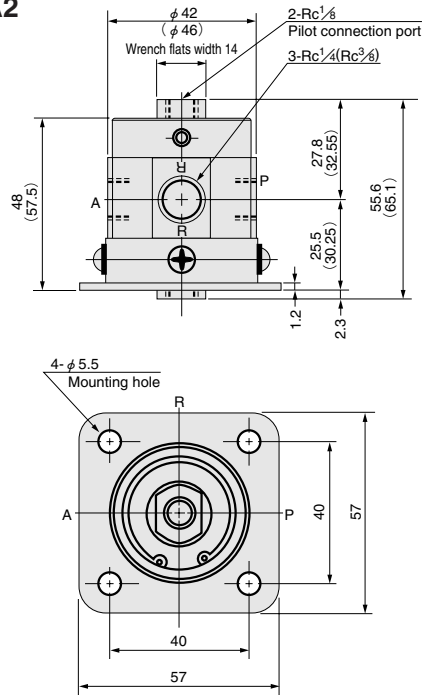

Note: The figures in parentheses ( ) are for the 2503A2.

## Flow Rate

### 125A2

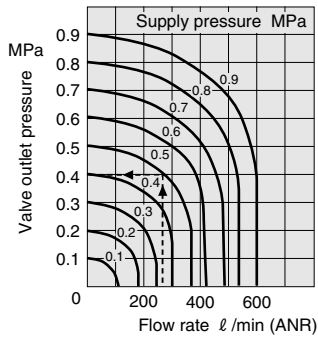

### 250A2 2503A2

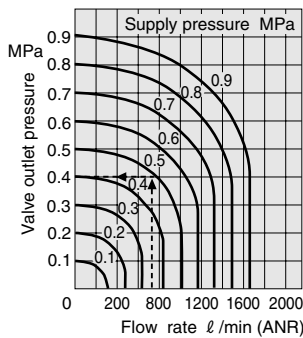

1MPa = 145psi.,  
1  $\ell/\text{min}$  = 0.0353ft<sup>3</sup>/min.

### How to read the graph

When the supply pressure is 0.5MPa [73psi.] and the flow rate is 740  $\ell/\text{min}$  [26.1ft<sup>3</sup>/min.] (ANR), the valve outlet pressure becomes 0.4MPa [58psi.].

## General Application Circuit

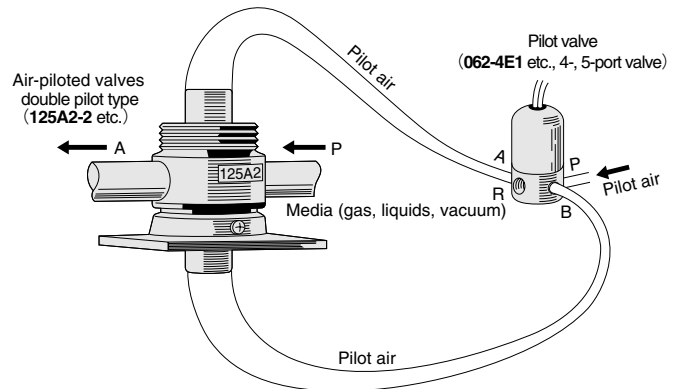

### Circuit diagram

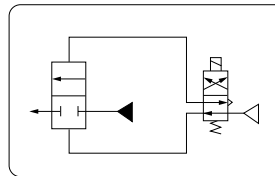

## Minimum Pilot Pressure

Model	Main (gas) pressure					
	0 [0]	0.1 [15]	0.3 [44]	0.5 [73]	0.7 [102]	0.9 [131]
125A2	0.16 [23]	0.18 [26]	0.33 [48]	0.51 [74]	0.67 [97]	0.82 [119]
250A2	0.1 [15]	0.20 [29]	0.39 [57]	0.57 [83]	0.74 [107]	0.84 [122]
2503A2						

Note: The above table assumes a gas media flowing through the main line. For liquid media, the pilot pressure will be slightly higher.

# Low Pressure Air-piloted Valves (Interface Valves)

125LA

## Symbols

2-port	3-port
NC (normally closed)	
125LA-2	125LA

## Specifications

Item	Basic model	125LA
Port size	Main	Rc1/8
	Pilot	M5×0.8 or Barbed fitting (barbed fitting for nylon tube φ6~4)
Effective area [Cv]	mm <sup>2</sup>	5.5 [0.27]
Media	Air	
	Operating pressure range MPa (kgf/cm <sup>2</sup> ) [psi.]	Main
	Pilot	0.001~0.003 {0.01~0.03} [0.15~0.44], Max.0.1 {1.0} [15] See the table "Minimum Pilot Pressure"
Proof pressure	Main	1.35 {13.8} [196]
	Pilot	0.1 {1.0} [15]
Bleed volume	ℓ /min [ft <sup>3</sup> /min.] (ANR)	Max. 1.5 [0.053] (0.5MPa [73psi.])
Operating temp. range (atmosphere and media)	°C [°F]	5~60 [41~140]
Maximum operating frequency	Hz	5
Lubrication		Not required
Mass	kg [lb.]	0.1 [0.22]

## Order Codes

### ● A type (normal type)

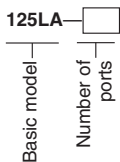

Number of ports

Code	Number of ports
Blank	3 ports
2	2 ports

## Minimum Pilot Pressure

Model	MPa [psi.]		
	Main pressure		
	0.2~0.35 [29~51]	0.35~0.56 [51~81]	0.56~0.9 [81~131]
125LA	0.002 [0.29]	0.0022 [0.32]	0.0029 [0.42]

## Operating Principles, Major Parts and Materials

### ● Normal condition

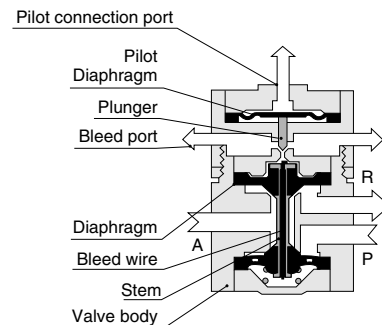

### ● Operating condition

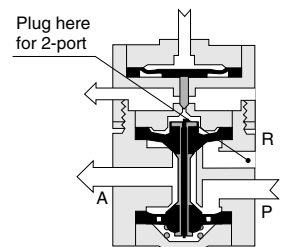

Parts	Materials
Body	Aluminum alloy (anodized)
Stem	Brass
Diaphragm	Synthetic rubber

## Dimensions (mm)

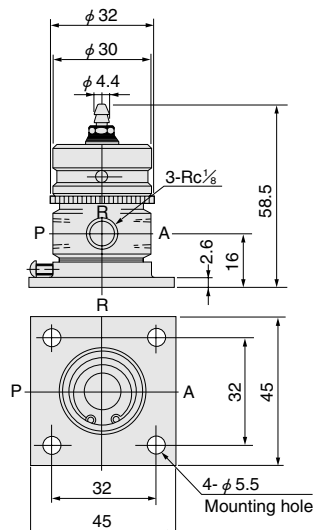

## Flow Rate

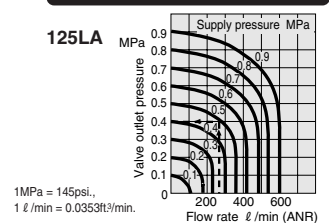

### How to read the graph

When the supply pressure is 0.5MPa [73psi.] and the flow rate is 275 ℓ/min [9.7ft<sup>3</sup>/min.] (ANR), the valve outlet pressure becomes 0.4MPa [58psi.].

## Handling Precautions

Do not apply higher pressure than the specified pilot pressure.  
Use an oil-removing air filter, etc., to prevent impure compressor oil, etc., from entering. To prevent clogging, supply the main line air through the filter to prevent solid objects from mixing into the flow.  
Supply a sufficient amount of air and pressure on the P port.

## Application Examples

### ● Confirmation of objects

When a workpiece is blocking the small hole, the pressure in the low pressure pilot line will rise, and 125LA will switch ON.

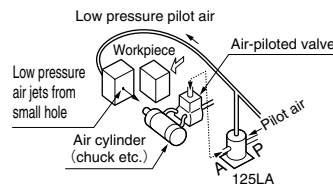

When a workpiece passes through, the sensor pilot on the left side activates, and 125LA will switch ON. If there is no workpiece, the sensor air jet on the right side blows off the left side's pilot air, and 125LA switches OFF.

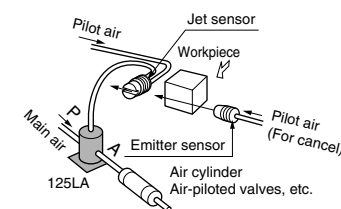

When a workpiece passes through the jet sensor and blocks the air jet, 125LA will switch OFF.

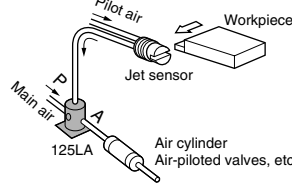

When a workpiece presses against and bends a rubber tube, the low-pressure pilot line's internal pressure will rise, and 125LA will switch ON.

(Use of a coil spring (dense pitch coils, with the end capped) in place of the rubber tube will cause an opposite action to the rubber tube, and switch OFF.)

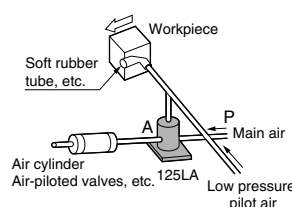

### ● Control of liquid level

When the liquid level rises, the low-pressure pilot line's internal pressure will rise, 125LA will switch ON, and the liquid control valve will activate.

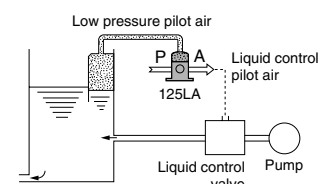

### ● Air timer

(Off delay timer = momentarily return during limited operation time)

Pressing the 2-port valve (pressing and releasing) switches the 125LA to ON, and switches it to OFF after a set period. Since the 125LA has a snap-action operation, the neutral position can be kept at the minimum level.

