



CAD drawing data catalog is available.



KOGANEI

GENERAL CATALOG OF AIR TREATMENT, AUXILIARY, VACUUM

HAND VALVES INDEX

Specifications, Order Code, Size Table	403
Dimensions	404
NCU Specifications Order Code, Model Table	406
Safety Precautions, Handling Instructions and Precautions	407

 **Caution** Before use, be sure to read the "Safety Precautions" on p. 31.

HAND VALVES

- These valves are for switching flow paths along piping.
- Can be mounted in various locations. Horizontal connection is also acceptable.

- Both 3-way valves (standard type and type with exhaust mechanism) and 2-way valves are available.

Symbols

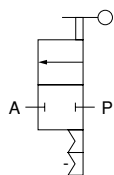

2-way valves

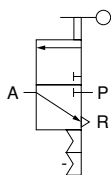

3-way valves

Specifications

Media	Air
Operating pressure range	0~0.9MPa {0~9.2kgf/cm ² } [0~131psi.]
Operating vacuum pressure	-100kPa {-750mmHg} [-14.5psi.]
Operating temperature range	0~60°C [32~140°F]
Recommended tube	Nylon tube, urethane tube
Sales unit	1 pc.

Note: The 3-way valve's R port cannot be used for piping connections.

Inner Construction, Major Parts and Materials

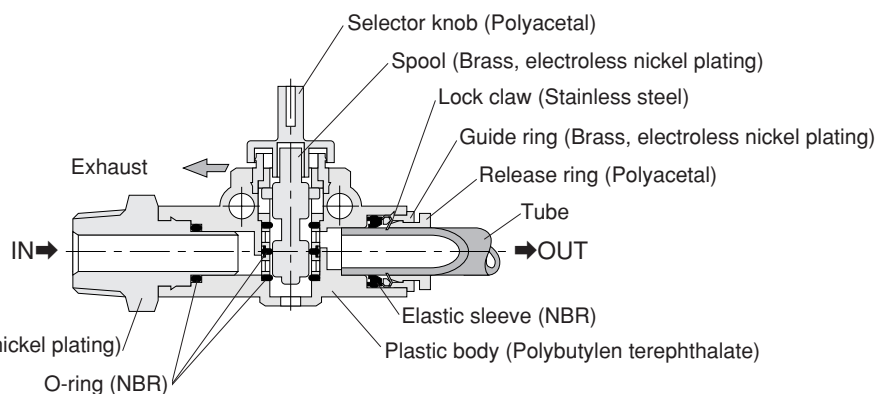

Order Code

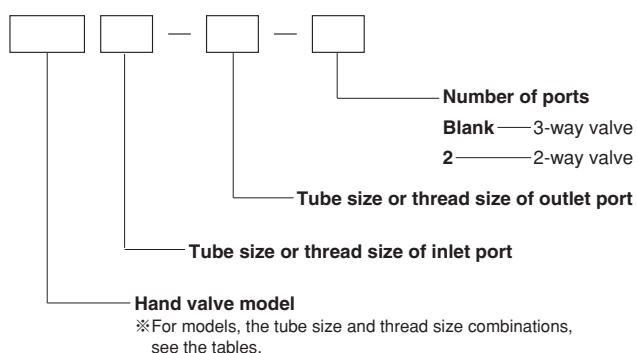

● FVA Straight A 404



Tube size	Thread size R			
	1/8	1/4	3/8	1/2
6	01	02	03	—
8	01	02	03	—
10	—	02	03	04
12	—	02	03	04

● For the NCU specifications, see p.406.

● FVB Straight B 404



Tube size	Thread size R			
	1/8	1/4	3/8	1/2
6	01	02	03	—
8	01	02	03	—
10	—	02	03	04
12	—	02	03	04

● FVN Nipple 405



Thread size R
1/8-1/8
1/4-1/8
1/4-1/4
3/8-1/4
3/8-3/8

● FVU Union straight 405



Tube size
6-6
8-6
8-8
10-10
12-10
12-12

Dimensions (mm)

Straight A FVA

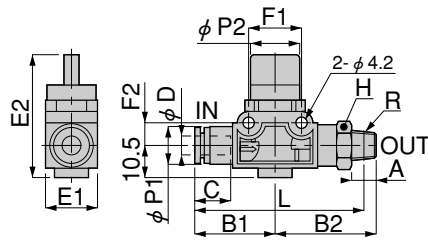

Model	Tube outer diameter ϕD	R	A	E1	E2	L ^{Note}	$\phi P1$	$\phi P2$	C	B1	B2	Width across flats H	F1	F2	Effective area (mm ²)	Mass (g) [oz.]
FVA6-01-□	6	R1/8	8	17	40.5	55.9	12.5	16.5	17	26.4	33.5	14	18	8	7.5	34 [1.20]
FVA6-02-□		R1/4	11			56.8					36.5				7.7	40 [1.41]
FVA6-03-□		R3/8	12			58.3					38.3				7.5	53 [1.87]
FVA8-01-□	8	R1/8	8	17	40.5	57.2	15	16.5	18.1	27.7	33.5	14	18	8	8.7	35 [1.23]
FVA8-02-□		R1/4	11			58.2					36.5				8.9	41 [1.45]
FVA8-03-□		R3/8	12			59.7					38.3				8.6	54 [1.90]
FVA10-02-□	10	R1/4	11	21	41	68.7	17.5	19.5	20.2	32.2	42.5	17	24	11	16.2	62 [2.19]
FVA10-03-□		R3/8	12			69.4					43.5				16	71 [2.50]
FVA10-04-□		R1/2	15			70.5					46.5				15.7	93 [3.28]
FVA12-02-□	12	R1/4	11	21	41	71.4	21	19.5	23.4	34.9	42.5	17	24	11	16.3	66 [2.33]
FVA12-03-□		R3/8	12			72.1					43.5				17.1	74 [2.61]
FVA12-04-□		R1/2	15			73.2					46.5				16.1	96 [3.39]

Note: The L dimensions are the reference dimensions after the fittings are assembled.

Straight B FVB

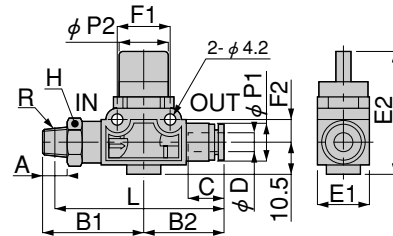

Model	Tube outer diameter ϕD	R	A	E1	E2	L ^{Note}	$\phi P1$	$\phi P2$	C	B1	B2	Width across flats H	F1	F2	Effective area (mm ²)	Mass (g) [oz.]
FVB01-6-□	6	R1/8	8	17	40.5	55.9	12.5	16.5	17	33.5	26.4	14	18	8	8.3	34 [1.20]
FVB02-6-□		R1/4	11			56.8				36.5					8.5	40 [1.41]
FVB03-6-□		R3/8	12			58.3				38.3					8.2	53 [1.87]
FVB01-8-□	8	R1/8	8	17	40.5	57.2	15	16.5	18.1	27.7	33.5	14	18	8	8.9	35 [1.23]
FVB02-8-□		R1/4	11			58.2					36.5				41 [1.45]	
FVB03-8-□		R3/8	12			59.7					38.3				54 [1.90]	
FVB02-10-□	10	R1/4	11	21	41	68.7	17.5	19.5	20.2	32.2	42.5	17	24	11	16.6	62 [2.19]
FVB03-10-□		R3/8	12			69.4					43.5				16.9	71 [2.50]
FVB04-10-□		R1/2	15			70.5					46.5				16.5	93 [3.28]
FVB02-12-□	12	R1/4	11	21	41	71.4	21	19.5	23.4	34.9	42.5	17	24	11	17	66 [2.33]
FVB03-12-□		R3/8	12			72.1					43.5				17.1	74 [2.61]
FVB04-12-□		R1/2	15			73.2					46.5				16.8	96 [3.39]

Note: The L dimensions are the reference dimensions after the fittings are assembled.

Dimensions (mm)

Nipple FVN

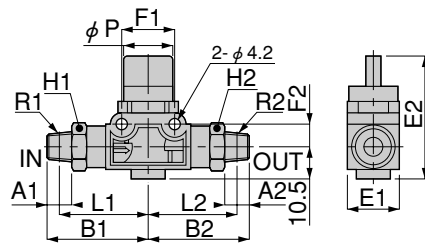

Model	R1	R2	A1	A2	E1	E2	L1 ^{Note}	L2 ^{Note}	ϕ P	B1	B2	Width across flats H1	Width across flats H2	F1	F2	Effective area (mm ²)	Mass (g) [oz.]
FVN01-01-□	1/8	1/8	8	8	17	40.5	29.5	29.5	16.5	33.5	33.5	14	14	18	8	8.8	43 [1.52]
FVN02-01-□	1/4	1/8	11	8	17	40.5	30.5	29.5	16.5	36.5	33.5	14	14	18	8	9	49 [1.73]
FVN02-02-□		1/4		11	21	41	36.5	36.5	19.5	42.5	42.5	17	17	24	11	15.8	80 [2.82]
FVN03-02-□	3/8	1/4	12	11	21	41	37.2	36.5	19.5	43.5	42.5	17	17	24	11	15.6	88 [3.10]
FVN03-03-□		3/8		12	37.2	43.5		43.5			15.7					96 [3.39]	

Note: The L1 and 2 dimensions are the reference dimensions after the fittings are assembled.

Union straight FVU

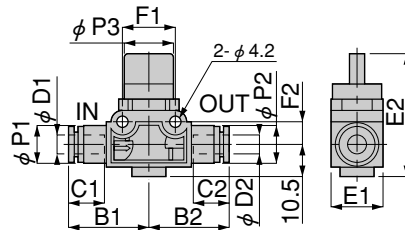

Model	Tube outer diameter ϕ D1	Tube outer diameter ϕ D2	E1	E2	ϕ P1	ϕ P2	ϕ P3	C1	C2	B1	B2	F1	F2	Effective area (mm ²)	Mass (g) [oz.]
FVU6-6-□	6	6	17	40.5	12.5	12.5	16.5	17	17	26.4	26.4	18	8	7.2	25 [0.88]
FVU8-6-□	8	6	17	40.5	15	12.5	16.5	18.1	17	27.7	26.4	18	8	8.1	26 [0.92]
FVU8-8-□		8				15			18.1		27.7			8.7	
FVU10-10-□	10	10	21	41	17.5	17.5	19.5	20.2	20.2	32.2	32.2	24	11	17.4	45 [1.59]
FVU12-10-□	12	10	21	41	21	17.5	19.5	23.4	20.2	34.9	32.2	24	11	17.5	48 [1.69]
FVU12-12-□		12				21			23.4		34.9			34.9	

Functions

● 3-way valve

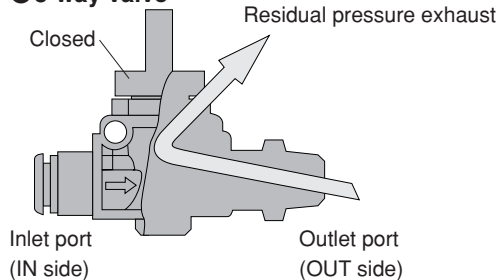

The 3-way valve can exhaust residual pressure (residual pressure remained in mounted equipment) left behind in the outlet port side when air has been shut off.

Ensures safe operations during equipment maintenance and repairs, etc.

The 2-way valve is suitable for air supply to tanks and other equipment where exhausting residual pressure is not desired.

The 2-way valve is also suitable for use in vacuum piping.

HAND VALVES

NCU Specifications

NCU Specifications

● Order Code

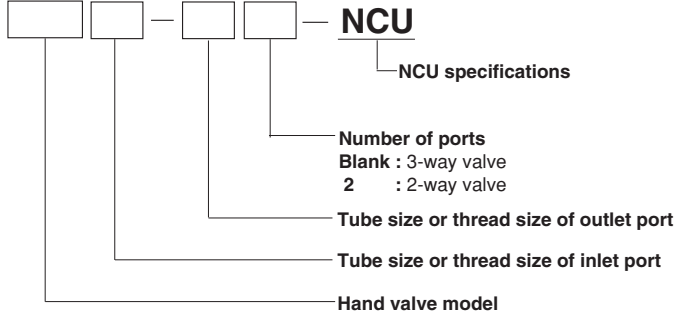

- For specifications, see p.403.
 - The dimensions, inner construction, major parts and materials for the NCU specifications shown below are the same as the standard type. See inner construction, major parts and materials on p.403 and dimensions on p. 404~405.
- The sealant is not applied to the R taper thread section of the NCU specifications.

Caution: For delivery times, consult us.

※For the fitting models, the tube size and thread combinations, see the table below. Columns showing the “←” symbol indicate that standard parts can be used for the NCU specifications. In these cases, place orders for the standard parts.

● Model Table(NCU Specifications)

Parts	Tube outer diameter	Thread	Standard type model (reference)	NCU specification model
Straight A FVA	6	R1/8	FVA6-01	FVA6-01-NCU
			FVA6-01-2	FVA6-01-2-NCU
		R1/4	FVA6-02	FVA6-02-NCU
			FVA6-02-2	FVA6-02-2-NCU
		R3/8	FVA6-03	FVA6-03-NCU
			FVA6-03-2	FVA6-03-2-NCU
	8	R1/8	FVA8-01	FVA8-01-NCU
			FVA8-01-2	FVA8-01-2-NCU
		R1/4	FVA8-02	FVA8-02-NCU
			FVA8-02-2	FVA8-02-2-NCU
		R3/8	FVA8-03	FVA8-03-NCU
			FVA8-03-2	FVA8-03-2-NCU
	10	R1/4	FVA10-02	FVA10-02-NCU
			FVA10-02-2	FVA10-02-2-NCU
		R3/8	FVA10-03	FVA10-03-NCU
			FVA10-03-2	FVA10-03-2-NCU
		R1/2	FVA10-04	FVA10-04-NCU
			FVA10-04-2	FVA10-04-2-NCU
	12	R1/4	FVA12-02	FVA12-02-NCU
			FVA12-02-2	FVA12-02-2-NCU
		R3/8	FVA12-03	FVA12-03-NCU
			FVA12-03-2	FVA12-03-2-NCU
		R1/2	FVA12-04	FVA12-04-NCU
			FVA12-04-2	FVA12-04-2-NCU
Straight B FVB	6	R1/8	FVB01-6	FVB01-6-NCU
			FVB01-6-2	FVB01-6-2-NCU
		R1/4	FVB02-6	FVB02-6-NCU
			FVB02-6-2	FVB02-6-2-NCU
		R3/8	FVB03-6	FVB03-6-NCU
			FVB03-6-2	FVB03-6-2-NCU
	8	R1/8	FVB01-8	FVB01-8-NCU
			FVB01-8-2	FVB01-8-2-NCU
		R1/4	FVB02-8	FVB02-8-NCU
			FVB02-8-2	FVB02-8-2-NCU
		R3/8	FVB03-8	FVB03-8-NCU
			FVB03-8-2	FVB03-8-2-NCU

Parts	Tube outer diameter	Thread	Standard type model (reference)	NCU specification model
Straight B FVB	10	R1/4	FVB02-10	FVB02-10-NCU
			FVB02-10-2	FVB02-10-2-NCU
		R3/8	FVB03-10	FVB03-10-NCU
			FVB03-10-2	FVB03-10-2-NCU
		R1/2	FVB04-10	FVB04-10-NCU
			FVB04-10-2	FVB04-10-2-NCU
	12	R1/4	FVB02-12	FVB02-12-NCU
			FVB02-12-2	FVB02-12-2-NCU
		R3/8	FVB03-12	FVB03-12-NCU
			FVB03-12-2	FVB03-12-2-NCU
		R1/2	FVB04-12	FVB04-12-NCU
			FVB04-12-2	FVB04-12-2-NCU
Nipple FVN	---	R1/8	FVN01-01	FVN01-01-NCU
			FVN01-01-2	FVN01-01-2-NCU
	---	R1/4,R1/8	FVN02-01	FVN02-01-NCU
			FVN02-01-2	FVN02-01-2-NCU
	---	R1/4	FVN02-02	FVN02-02-NCU
			FVN02-02-2	FVN02-02-2-NCU
	---	R3/8,R1/4	FVN03-02	FVN03-02-NCU
			FVN03-02-2	FVN03-02-2-NCU
---	R3/8	FVN03-03	FVN03-03-NCU	
		FVN03-03-2	FVN03-03-2-NCU	
Union straight FVU	6-6	---	FVU6-6	←
			FVU6-6-2	←
	8-6	---	FVU8-6	←
			FVU8-6-2	←
	8-8	---	FVU8-8	←
			FVU8-8-2	←
	10-10	---	FVU10-10	←
			FVU10-10-2	←
	12-10	---	FVU12-10	←
			FVU12-10-2	←
	12-12	---	FVU12-12	←
			FVU12-12-2	←

HAND VALVES

Safety Precautions (Hand Valves)

The following is a safety precaution to Hand Valves. For other safety precautions, be sure to read the precautions on p.31.

Caution

- Firmly twist the selector knob until it stops at the 90° position. Failure to completely turn the selector knob can reduce switching capability, resulting in inadequate flow rate and more resistance.
- The 2-way and 3-way valves can be identified by the ② and ③ numbers stamped onto the top surface of the selector knob.
- For vacuum pressure use, install a vacuum filter on the suction side. Foreign particles sucked into the system could cause defective operation.

Handling Instructions and Precautions

● Mounting

Precautions for mounting the body

1. To tighten the hand valve's taper pipe thread, use a suitable tool to tighten on the outer hexagonal sections of the hand valve's body.
2. When tightening body thread, tighten to the recommended tightening torque shown in the table below. Tightening to more than the recommended torque could lead to damage thread sections or air leaks due to deformation. Tightening to less than the recommended torque could lead to loose body thread or air leaks.

Recommended tightening torque

Thread type	Thread	Tightening torque
Taper pipe thread	R1/8	7~9N·m(71.38~91.77kgf·cm) [5.16~6.64ft·lbf]
	R1/4	12~14N·m(122.37~142.76kgf·cm) [8.85~10.3ft·lbf]
	R3/8	22~24N·m(224.34~244.73kgf·cm) [16.2~17.7ft·lbf]
	R1/2	28~30N·m(285.52~305.92kgf·cm) [20.7~22.1ft·lbf]

Precautions for disconnecting the body

1. To disconnect the hand valve's taper pipe thread, use a suitable tool to loosen it on the outer hexagonal sections of the hand valve's body.
2. Clean off the sealant coating on the thread of the removed mating part. The coated sealant could enter other relating parts, and cause breakdowns.

Securing method

1. Tightening method on outer hexagonal section

To mount the body, use a wrench to tighten the outer hexagonal sections of the straight A, B or nipple type hand valves.

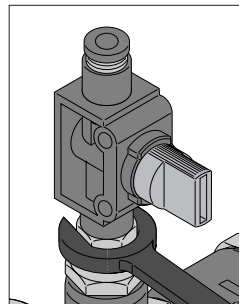

2. Securing method for the body

The hand valve union straight type is secured in place with M4 screws through mounting holes on the plastic body. (For mounting hole pitch, see the external dimensions in this section.)

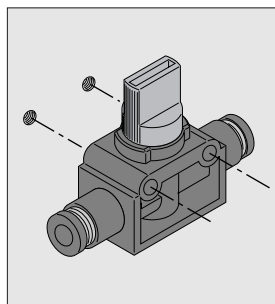

● Tube connection and disconnection

Precautions for connecting the tube

1. Check that the cut section of the tube has been cut at straight angle, that the outer surface of the tube is not scratched, and that the tube has not become oval shaped.
2. When connecting a tube, failure to insert the tube all the way to the end could result in air leaks.

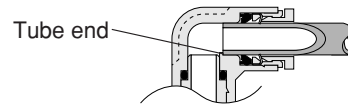

3. After connection, pull the tube to check that it will not disconnect.

Precautions for disconnecting the tube

1. Before disconnecting a tube, check that the pressure inside the tube is down to zero.
2. Push the release ring evenly all the way to the end, and then pull the tube out. An insufficient push could make it impossible to pull out the tube, or could scratch the tube, leaving scratched tube material inside the fitting.

Tube connection and disconnection method

1. Tube connection

The Hand Valve is equipped with a lock claw that holds the tube in place when it has been pushed all the way to the end, and with an elastic sleeve for sealing the tube periphery.

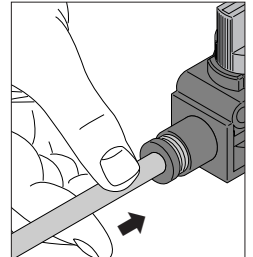

2. Tube disconnection

To disconnect the tube, first push on the release ring, releasing the lock claw, and then pull out the tube.

Always stop the air supply before removing the tube.

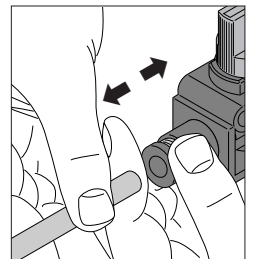

Handling Instructions and Precautions

For cases where tight or cramped piping spaces hinder tube removal operations, a special tool is available. Consult us for details.

Special tool for tube removal

For $\phi 3$, $\phi 4$ and $\phi 6$ tubes
Order code : **UJ-1**



For $\phi 6$, $\phi 8$, $\phi 10$ and $\phi 12$ tubes
Order code : **UJ-2**



● Usable tubes

Either nylon or urethane tubes can be used. The tube outer diameter accuracy should be, for nylon tubes, within $\pm 0.1\text{mm}$ [$\pm 0.004\text{in.}$] of the nominal dimensions, and for urethane tubes, within $\pm 0.15\text{mm}$ [$\pm 0.006\text{in.}$] of the nominal dimensions, while the ovalness (difference between long diameter and short diameter) should be within 0.2 mm [0.008in.].

Cautions: 1. Use tubes with no visible scratches on the outer surface. If a scratch is made during repeated use, cut off the scratched section.

2. Do not bend or twist the tube too much near the connection to the fitting. It could result in air leaks. The minimum bending radius for nylon tubes is as shown in the table below.

mm [in.]	
Tube size	Minimum bending radius
$\phi 4$ [0.16]	20 [0.8]
$\phi 6$ [0.24]	30 [1.2]
$\phi 8$ [0.31]	50 [2.0]
$\phi 10$ [0.39]	80 [3.2]
$\phi 12$ [0.47]	150 [5.9]

● Selector knob operation method

To supply the air

Turn the selector knob clockwise until it stops at the 90° position, supplying the air.

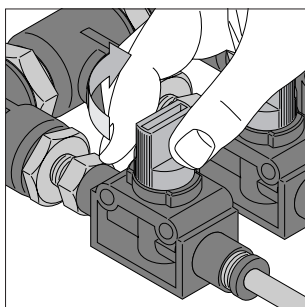

To shut off the air supply

Turn the selector knob counter-clockwise until it stops at the 90° position, shutting off the air. In the 3-way valve, residual pressure on the OUT side is exhausted at the same time when the selector knob's twist is completed.

