



CAD drawing data catalog is available.



KOGANEI

ACCESSORIES GENERAL CATALOG

**AIR TREATMENT, AUXILIARY, VACUUM,
AND FLUORORESIN PRODUCTS**

**SPEED CONTROLLERS, MUFFLERS,
EXHAUST FILTERS,
AIR-HYDRO CONVERTERS, AIR BLEEDERS,
HOLDERS AND COLUMN TUBES,
AIR INDICATORS**

CONTENTS

Speed Controllers	
TSCO Series	
Specifications, Inner Construction and Major Parts	539
Order Codes, Dimensions	540
TSC Series	
Specifications, Order Codes, Inner Construction and Major Parts	541
Dimensions	542
SC Series	
Specifications, Order Codes, Inner Construction and Major Parts	543
Dimensions	544
SCL Series	
Specifications, Inner Construction and Major Parts, Order Codes	545
Dimensions	546
KSC Series	
Specifications, Order Codes, Inner Construction and Major Parts	547
Dimensions	548
Mufflers	
Made of Plastic	549
Made of Brass	551
Exhaust Filters	
Specifications, Order Codes	552
Dimensions, Selection Reference Graph	553
Air-hydro Converters	
Specifications, Order Codes	554
Selection Guideline	555
Dimensions	556
Handling Instructions and Precautions	557
Air Bleeders	
Specifications, Order Codes	558
Handling Instructions and Precautions	559
Holder and Column Tubes	
Order Codes, Dimensions	560
Air Indicators	562



Caution Before use, be sure to read the "Safety Precautions" on p. 49.

SPEED CONTROLLERS TSCO SERIES

M3×0.5

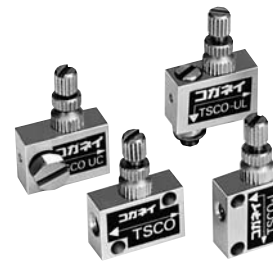

- Offer fine speed control for the M3 ported Pen Cylinders.
- Compact, lightweight, and easy to handle.

Specifications

Item	Model	TSCO	TSCO-L	TSCO-UC	TSCO-UL
Piping type	Controlled flow P	Female thread		Universal male thread	
	Controlled flow A	Female thread			
Port size		M3×0.5			
Media		Air			
Operating pressure range	MPa [psi.]	0~0.7 [0~102]			
Proof pressure	MPa [psi.]	1.03 [149]			
Cracking pressure	MPa [psi.]	0.05 [7.3]			
Operating temperature range	°C [°F]	5~60 [41~140]			
Mass	g [oz.]	5 [0.18]	4 [0.14]	6 [0.21]	6 [0.21]

Symbol

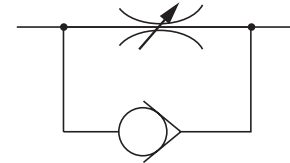

Flow Rate Characteristics

● Controlled flow

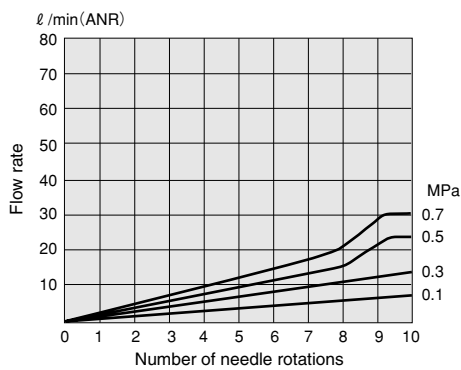

● Free flow

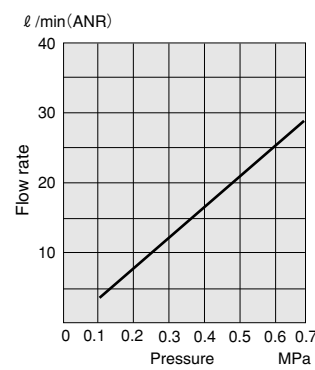

1MPa = 145psi. 1 l/min = 0.0353ft³/min.

Inner Construction and Major Parts

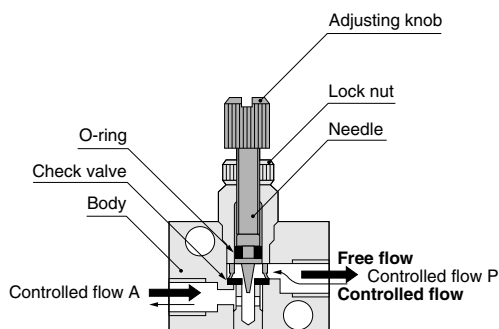

Major Parts and Materials

Parts	Materials
Body	Brass (nickel plated)
Needle	Stainless steel
Lock nut	Brass (nickel plated)
Check valve	Synthetic rubber (NBR)
O-ring	
Adjusting knob	Brass (nickel plated)

Order Codes



Model

TSCO

TSCO-L

TSCO-UC

TSCO-UL

Non-ion specification

Blank — Standard specification

NCU — Non-ion specification

Dimensions (mm)

TSCO

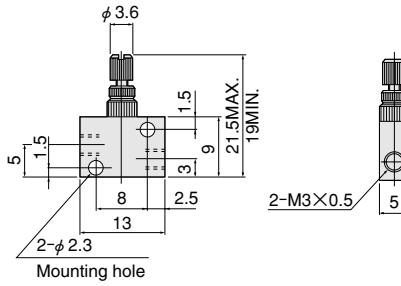

TSCO-L

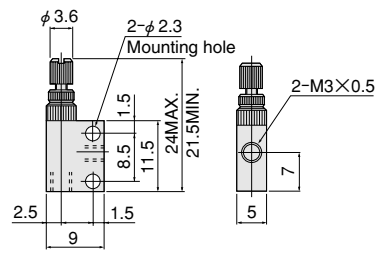

TSCO-UC

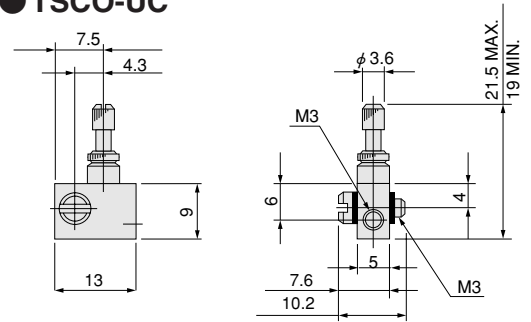

TSCO-UL

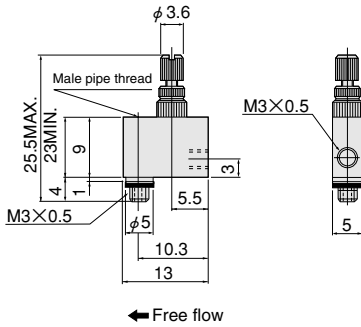

Handling Instructions and Precautions

- Always use fingertips to rotate and tighten the lock nut and needle.
Use of excessive tightening force with tools, etc., could cause damage to the units.
- When using a universal male thread type for piping, secure at the male pipe thread portion. The tightening torque should not exceed $0.5\text{N} \cdot \text{m}$ [$4.4\text{in} \cdot \text{lbf}$].

SPEED CONTROLLERS TSC SERIES

M5×0.8, With Clamp Fitting

- Compact and lightweight, optimum for Pen Cylinders and Jig Cylinders.
- Wide variation of products allows mounting in any direction.
- Straight type and L type offer a choice of piping directions.

Symbol

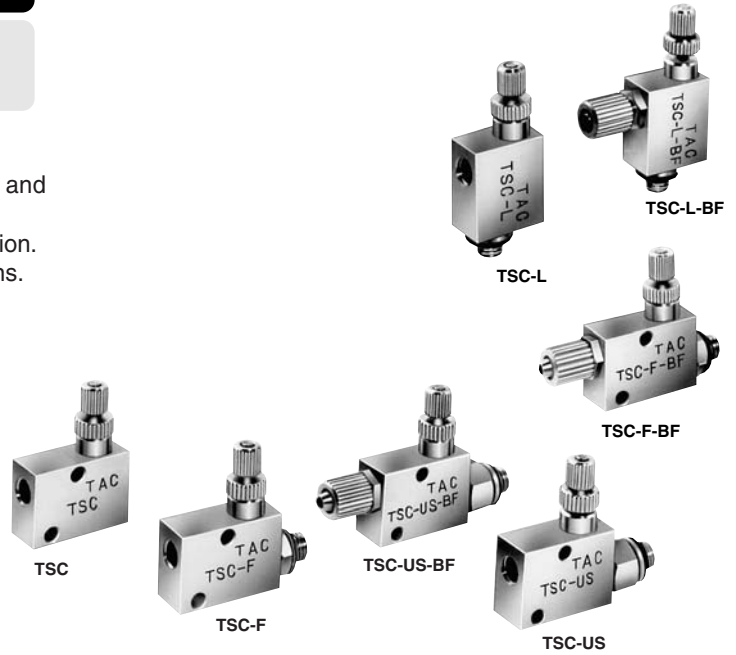
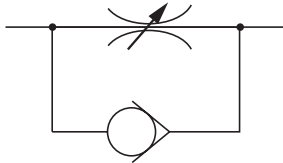

Specifications

Item	Model	TSC	TSC-F	TSC-F-BF	TSC-US	TSC-US-BF	TSC-L	TSC-L-BF
Piping type and port size	Controlled flow P	Female thread M5×0.8	Male thread M5×0.8		Union male thread M5×0.8		Male thread M5×0.8	
	Controlled flow A	Female thread M5×0.8		For urethane tube φ 4×2.5 Clamp fitting	Female thread M5×0.8	For urethane tube φ 4×2.5 Clamp fitting	Female thread M5×0.8	For urethane tube φ 4×2.5 Clamp fitting
Media		Air						
Operating pressure range	MPa [psi.]	0~0.9 [0~131]						
Proof pressure	MPa [psi.]	1.32 [191]						
Cracking pressure	MPa [psi.]	0.05 [7.3]						
Operating temperature range	°C [°F]	5~60 [41~140]						
Mass	g [oz.]	16 [0.56]	18 [0.63]	20.5 [0.72]	19 [0.67]	21.5 [0.76]	15 [0.53]	17 [0.60]

Order Codes

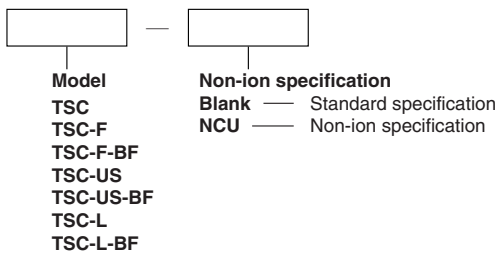

Inner Construction and Major Parts

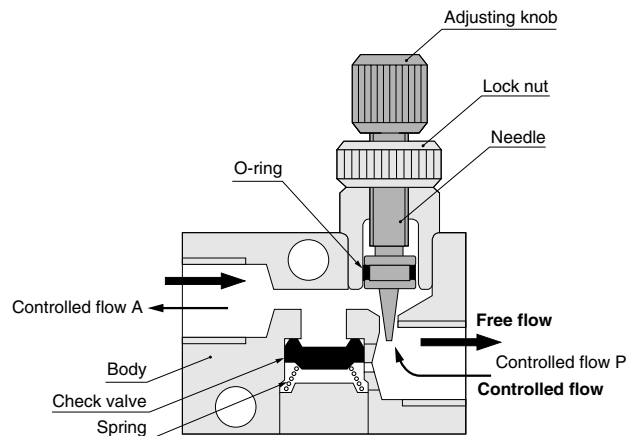

Major Parts and Materials

Parts	Materials
Body	Brass (nickel plated)
Needle	Stainless steel
Lock nut	Brass (nickel plated)
Check valve	Synthetic rubber (NBR)
O-ring	
Adjusting knob	Brass (nickel plated)

Dimensions (mm)



● Straight type ● TSC

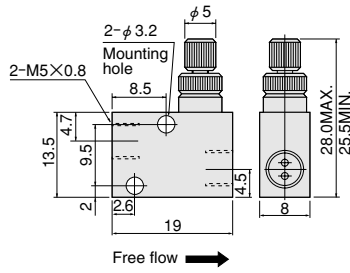

● TSC-F

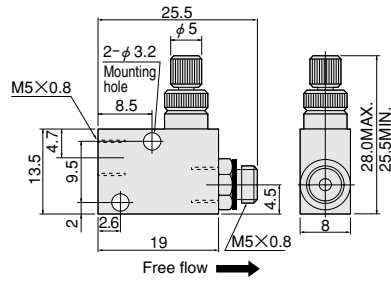

● TSC-F-BF

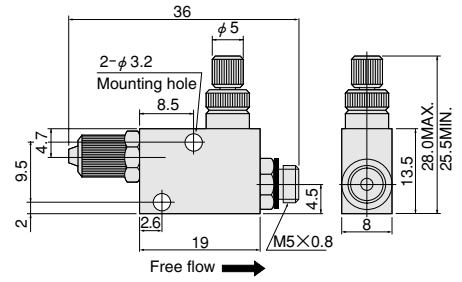

● TSC-US

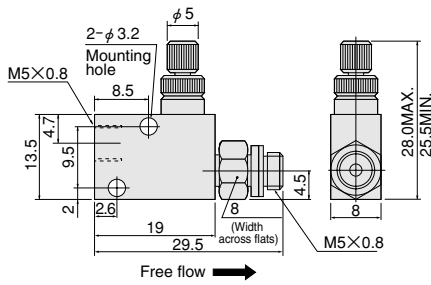

● TSC-US-BF

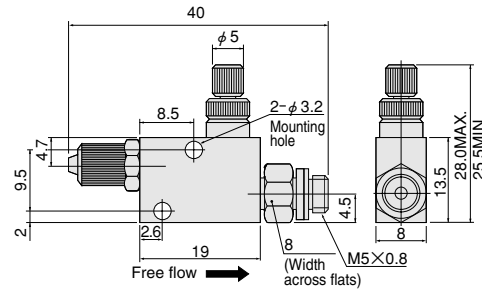

● L type ● TSC-L

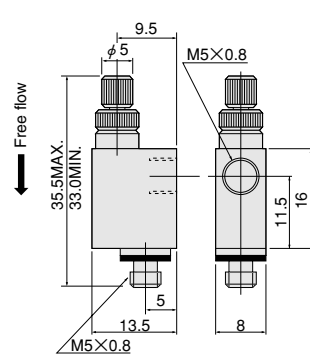

● TSC-L-BF

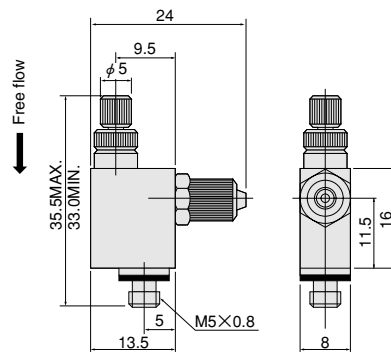

Flow Rate Characteristics

● Controlled flow

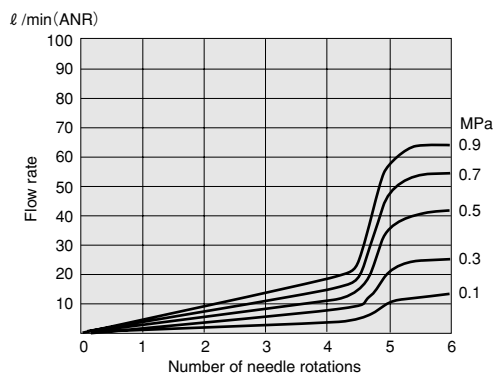

1MPa = 145psi. 1 l/min = 0.0353ft³/min.

● Free flow

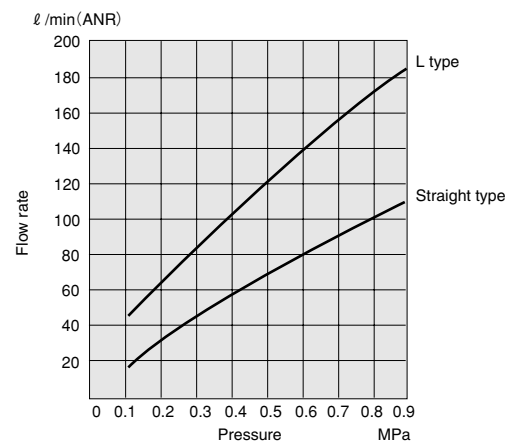

SPEED CONTROLLERS SC SERIES

M5×0.8, Rc1/8

- Compact and lightweight, optimum for Pen Cylinders, Jig Cylinders, and Slim Cylinders.
- Straight type and L type offer mounting in any direction.
- Union type allows piping and needle setting in any direction.

Symbol

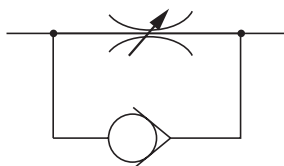

Specifications

Item	Model	SC0	SC0-F	SC0-US	SC0-UL	SC1	SC2
Piping type		Female thread	Male thread	Union male thread Straight Elbow		Female thread	
Port size		M5×0.8					Rc1/8
Operating pressure range	MPa [psi.]	0~0.9 [0~131]					
Proof pressure	MPa [psi.]	1.32 [191]					
Cracking pressure	MPa [psi.]	0.05 [7.3]				0.04 [5.8]	0.03 [4.4]
Operating temperature range	°C [°F]	5~60 [41~140]					
Mass	g [oz.]	30 [1.06]	35 [1.23]	36 [1.27]	88 [3.10]	55 [1.94]	

Order Codes

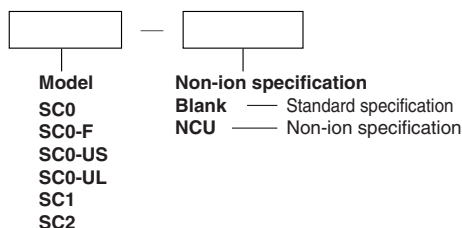

Inner Construction and Major Parts

●SC0

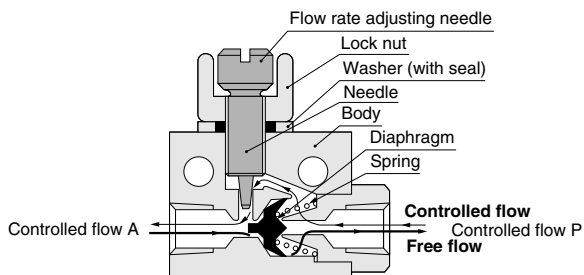

●SC1

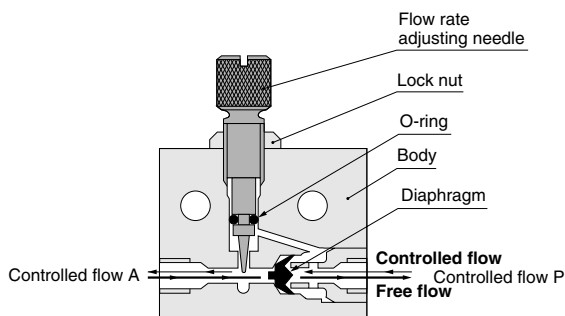

●SC2

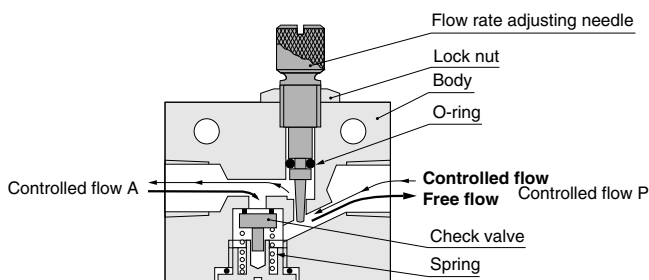

Major Parts and Materials

Parts	Materials
Body	Brass (nickel plated) ^{Note}
Needle	Stainless steel
Lock nut	Brass (nickel plated)
Check valve	Synthetic rubber (NBR)
O-ring	
Flow rate adjusting needle	Brass (nickel plated)

Note :SC2 is made of aluminum alloy (anodized).

Dimensions (mm)

SC0

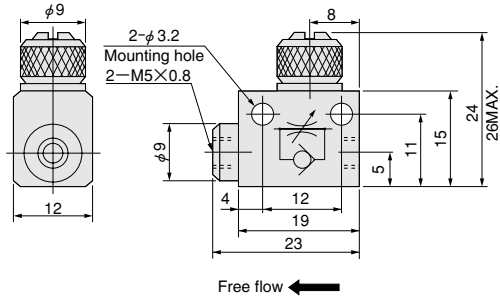

SC0-US

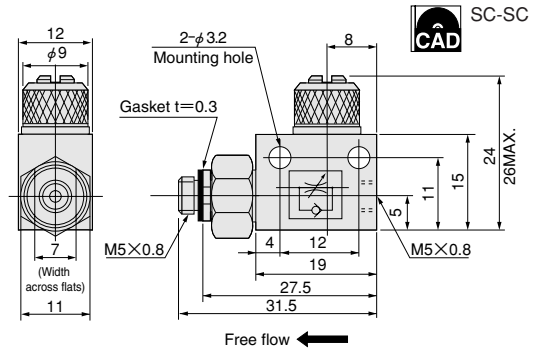

SC0-F

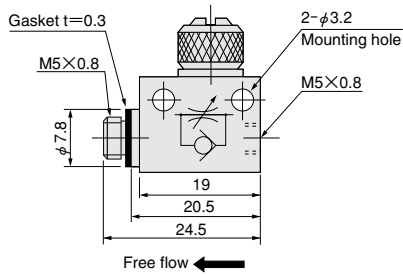

SC0-UL

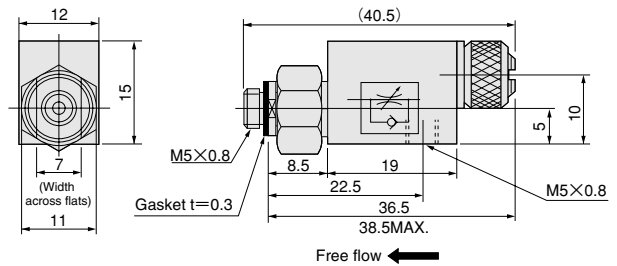

SC1

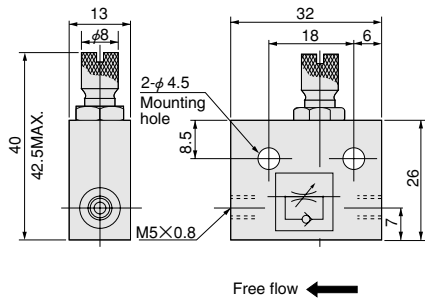

SC2

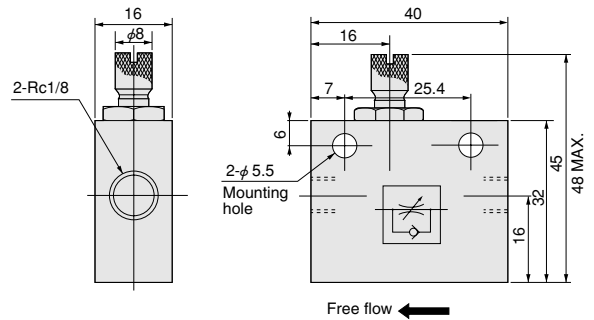

Flow Rate Characteristics

SC0

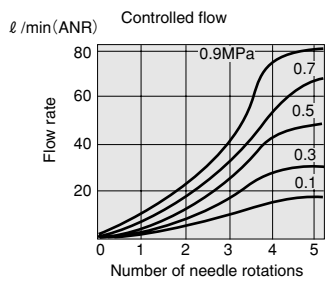

SC1

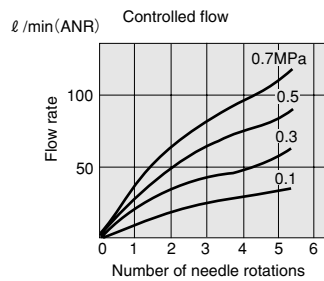

SC2

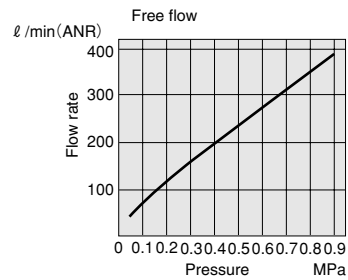
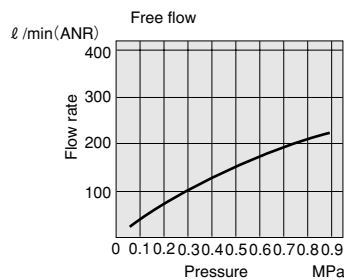
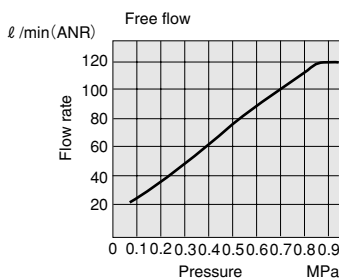
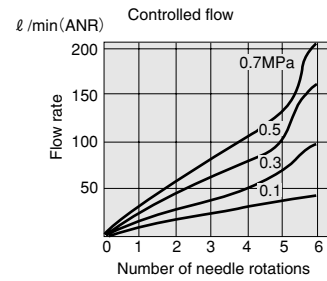

1 MPa = 145psi.
1 l/min = 0.0353ft³/min.

SPEED CONTROLLERS SCL SERIES

Male thread, R1/8, R1/4
Female thread, Rc1/8, Rc1/4

- Compact and lightweight, optimum for Slim Cylinders, etc.
- Enables direct connection to cylinder connection ports, eliminating the piping work and materials.
- Can install L shaped piping to maintain compact piping setups.

Symbol

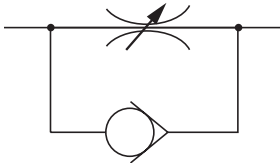

SCL1

SCL2

Specifications

Item	Model	SCL1	SCL2
Mounting type		Male thread specification, enabling direct cylinder mounting	
Port size		R1/8 Controlled flow P: male thread A: female thread Rc1/8	R1/4 Controlled flow P: male thread A: female thread Rc1/4
Media		Air	
Operating pressure range	MPa [psi.]	0~0.9 [0~131]	
Proof pressure	MPa [psi.]	1.32 [191]	
Cracking pressure	MPa [psi.]	0.06 [8.7]	
Operating temperature range	°C [°F]	5~60 [41~140]	
Mass	g [oz.]	46 [1.62]	125 [4.41]
Materials	Body	Brass (nickel plated)	
	Needle	Stainless steel	
	Seal	Synthetic rubber (NBR)	

Inner Construction and Major Parts

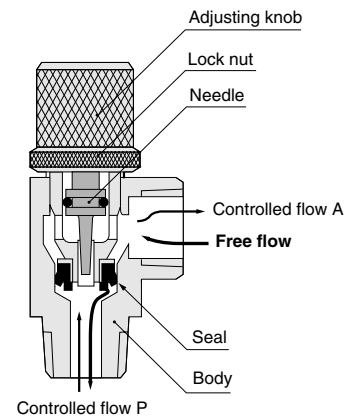

Order Codes

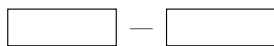

Model
SCL1
SCL2

Non-ion specification
Blank — Standard specification
NCU — Non-ion specification

Dimensions (mm)

● SCL1

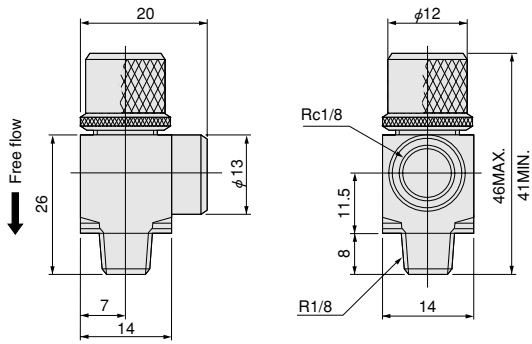

● SCL2

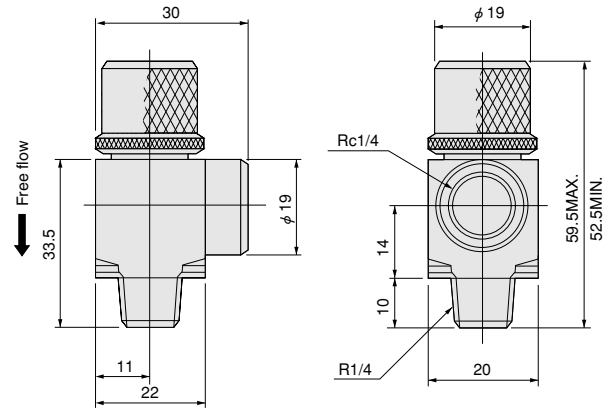

Flow Rate Characteristics

● SCL1

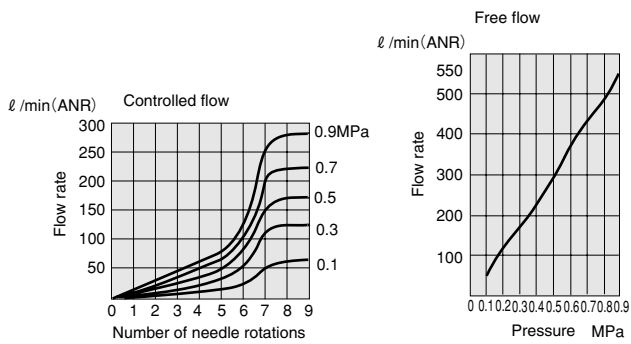

1MPa = 145psi. 1 ℓ/min = 0.0353ft³/min

● SCL2

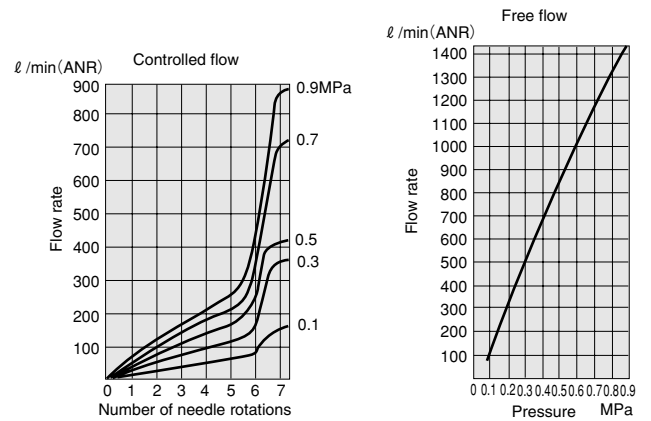

1MPa = 145psi. 1 ℓ/min = 0.0353ft³/min.

SPEED CONTROLLERS KSC SERIES

Rc1/8 ~ Rc1

- Easy to adjust flow rate.
- Maintain stable flow rate.
- Compact and easy mounting.

Symbol

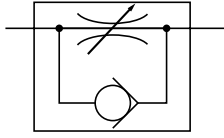

Specifications

Item	Model	KSC11	KSC22	KSC21	KSC31	KSC41	KSC6	KSC8
Port size	Rc	1/8	1/4		3/8	1/2	3/4	1
Effective area	mm ²	5.5 [0.31]	10 [0.56]	32 [1.78]	38 [2.11]	38 [2.11]	67 [3.72]	90 [5]
	[Cv]	3.0 [0.17]	6.5 [0.36]	22 [1.22]	22 [1.22]	22 [1.22]	62 [3.44]	103 [5.72]
Operating pressure range	MPa [psi.]	0.9 [131]						
Proof pressure	MPa [psi.]	1.3 [189]						
Cracking pressure	MPa [psi.]	0.06 [8.7]	0.02 [2.9]				0.01 [1.5]	
Operating temperature range	°C [°F]	5 ~ 60 [41 ~ 140]						
Mass	g [oz.]	90 [3.17]	130 [4.59]	420 [14.8]			960 [33.9]	880 [31.0]
Body material		Zinc die-casting			Aluminum die-casting			

Order Codes



- Model
 KSC11
 KSC22 KSC41
 KSC21 KSC6
 KSC31 KSC8
- Non-ion specification
 Blank — Standard specification
 NCU — Non-ion specification

Inner Construction and Major Parts

● KSC11

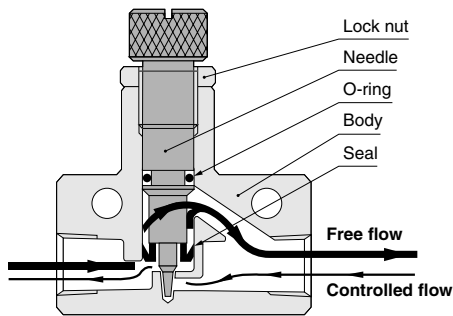

● KSC22

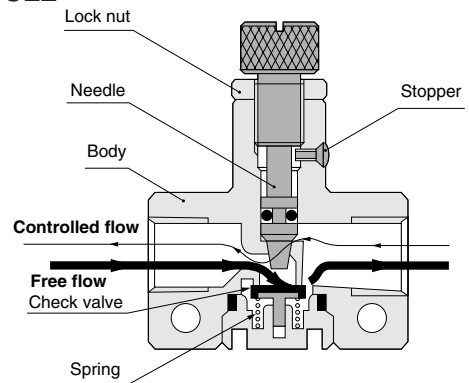

● KSC21

● KSC31

● KSC41

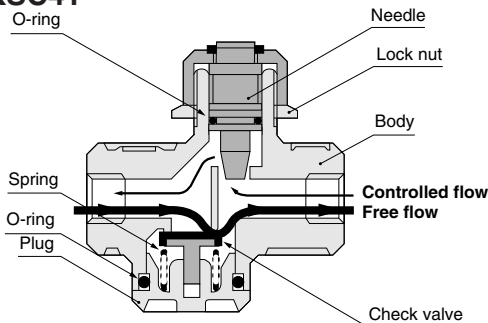

● KSC6

● KSC8

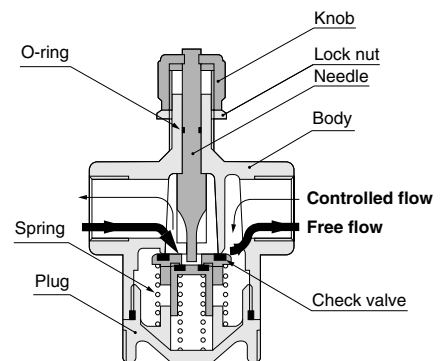

Note: In **KSC6** and **KSC8**, turning the knob clockwise increases the controlled flow rate, while turning the knob counterclockwise reduces it.
 (For all other models, this is reversed.)

Dimensions (mm)

● KSC11

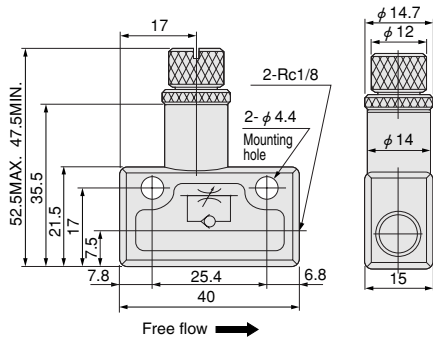

● KSC22

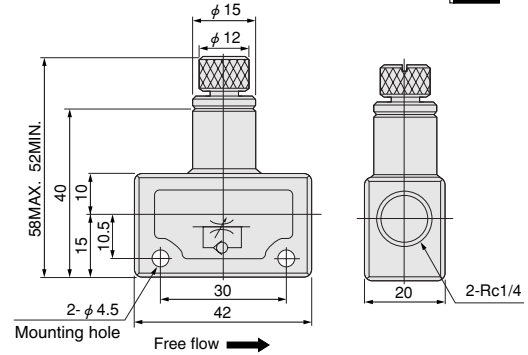

● KSC21 ● KSC31 ● KSC41

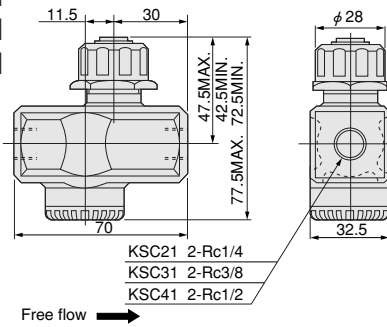

● KSC6 ● KSC8

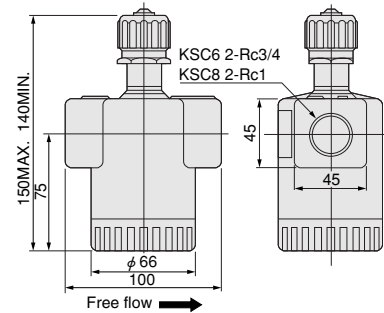

Flow Rate Characteristics

● KSC11

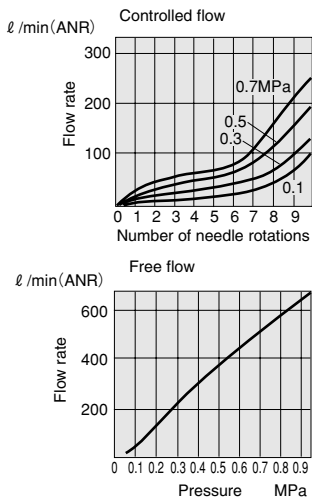

● KSC22

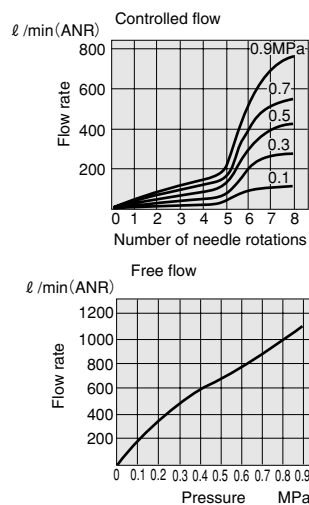

● KSC21

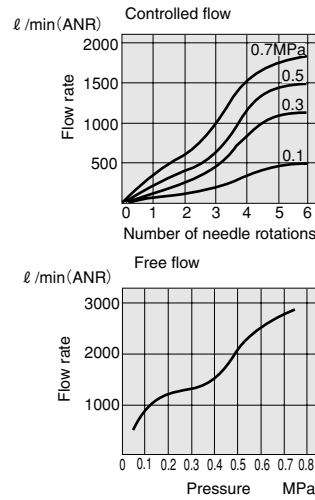

● KSC31

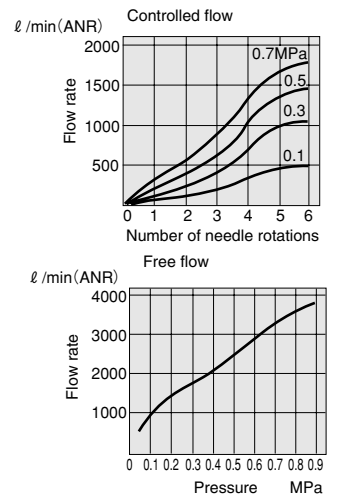

● KSC41

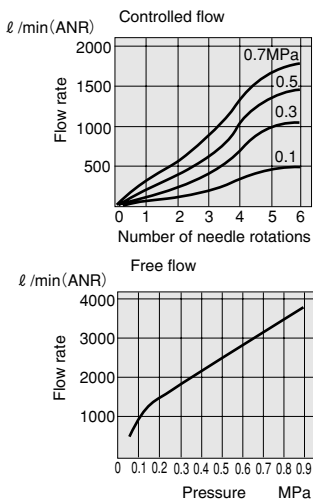

● KSC6

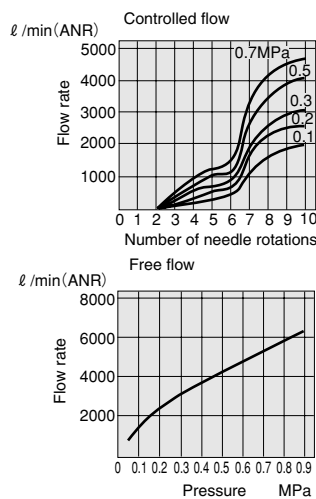

● KSC8

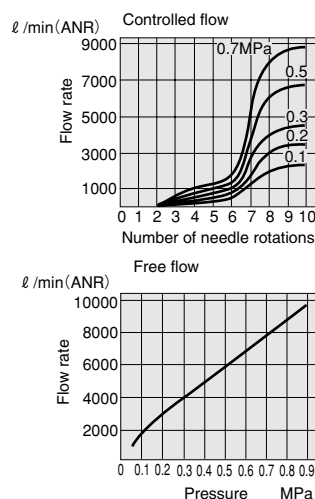

1 MPa = 145psi.
1 ℓ/min = 0.0353ft³/min.

MUFFLERS Made of Plastic

M3 × 0.5 ~ R1/2

- Offer superior noise suppressing effect.
- Low resistance to air flow, thus avoiding adverse effects on equipment operations.
- Compact and lightweight, for easy mounting.
- Offer a long operating life. Elements do not corrode over time, and maintain superior moisture and oil resistance.
- Cleaning with petroleum, etc., is a simple operation.

Symbol



Specifications

Item	Model	KM-03	KM-05	KM-10	KM-11	KM-22	KM-23	KM-31	KM-41
Port size		M3×0.5	M5×0.8	R1/8		R1/4		R3/8	R1/2
Media		Air							
Operating pressure range	MPa [psi.]	0~0.7 [0~102]			0~0.9 [0~131]				
Proof pressure	MPa [psi.]	0.9 [131]			1.1 [160]				
Operating temperature range	°C [°F]	5~60 [41~140]							
Materials	Body	Polyacetal (Duracon)							
	Element	Expanded polyethylene (filtration rating 10 μm)		Polyvinyl alcohol resin (sponge, filtration rating 5 μm)	Sintered polyethylene (filtration rating 20 μm)		Sintered polyethylene (filtration rating 40 μm)		Sintered polyethylene (filtration rating 20 μm)
Effective area	mm ² [Cv]	1.0 [0.06]	4.0 [0.22]	5.5 [0.31]	15 [0.83]	21 [1.17]	43 [2.39]	65 [3.61]	74 [4.11]
Noise suppressing effect	dB	15 ^{Note}	13 ^{Note}	7	18	18	18	27	34
Mass	g [oz.]	0.5 [0.018]	1.0 [0.035]	0.9 [0.032]	4 [0.14]	4.5 [0.16]	18 [0.63]	19.5 [0.69]	22 [0.78]
Sales unit		One pack (10 pcs.)							

Note: Values at air pressure of 0.5MPa [73psi.] with installation in solenoid valve. (Solenoid valve used: **KM-03** for **040-4E1**, **KM-05** for **050-4E1**)

Item	Model	KM-J6	KM-J8	KM-J10	KM-J12
Port size		φ 6	φ 8	φ 10	φ 12
Media		Air			
Operating pressure range	MPa [psi.]	0~0.7 [0~102]			
Proof pressure	MPa [psi.]	0.9 [131]			
Operating temperature range	°C [°F]	5~60 [41~140]			
Materials	Body	Polyacetal (Duracon)			
	Element	Polyvinyl alcohol			
Effective area	mm ² [Cv]	9.8 [0.54]	21 [1.17]	25 [1.39]	42 [2.33]
Noise suppressing effect	dB	23	33	35	28
Mass	g [oz.]	1.3 [0.046]	3.9 [0.138]	6.5 [0.23]	9 [0.32]
Sales unit		One pack (10 pcs.)			

Dimensions (mm)

● KM-03

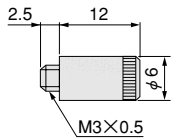

● KM-05

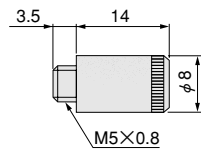

● KM-10

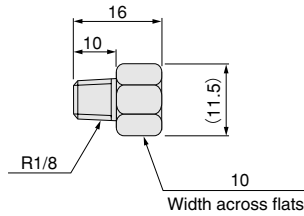

● KM-J6

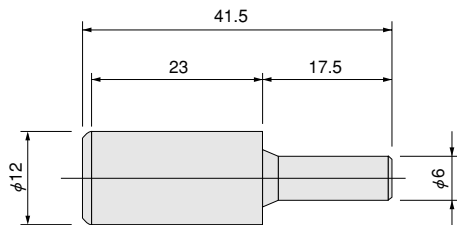

● KM-11 ~ KM-41

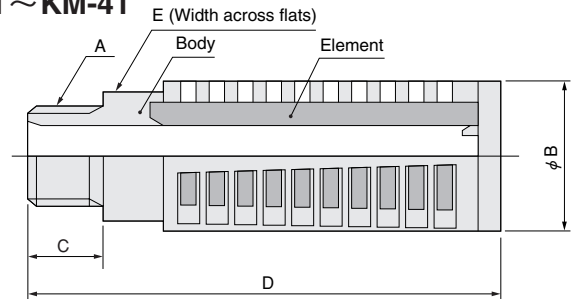

Code Model	A (R)	B	C	D	E (width across flats)
KM-11	1/8	16	7	33	14
KM-22	1/4	16	10	36	14
KM-23	1/4	20	10	62.5	17
KM-31	3/8	26	12	68	24
KM-41	1/2	28	15	71	24

● KM-J8 ~ KM-J12

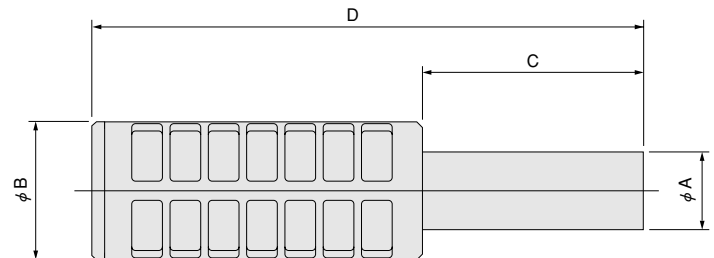

Code Model	A	B	C	D
KM-J8	8	15	26	64
KM-J10	10	18	30	73
KM-J12	12	20	35	83

Handling Instructions and Precautions

- As the body is made of plastic, do not subject it to excessive force.
- For cleaning, use a neutral detergent or cleaning oil. Do not use thinner, benzene, or other solvents.

● KM-03, KM-05

Use fingertips to tighten for mounting. Use of pliers or other tools could damage the unit.

● KM-10 ~ KM-41

Use fingertips to tighten until it stops. Then, use a tool to lightly tighten a little further.

● KM-J6 ~ KM-J12

Use by inserting into the quick fitting. After mounting, check that the muffler cannot be pulled out.

MUFFLERS Made of Brass

M5 × 0.8, R1/8 ~ R1

- Made of sintered brass, which assures superior mechanical strength.
- Compact body takes up little installation space.

Symbol

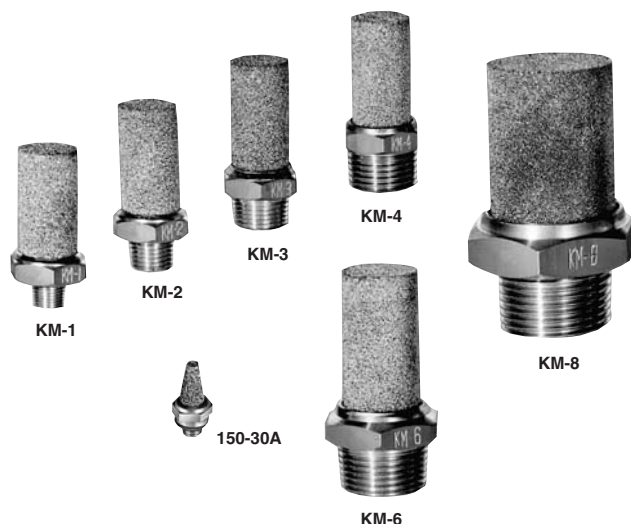

Specifications

Item	Model	150-30A	KM-1	KM-2	KM-3	KM-4	KM-6	KM-8
Port size		#10-32 Unified thread (Can be used with M5×0.8)	R1/8	R1/4	R3/8	R1/2	R3/4	R1
Media		Air						
Operating pressure range	MPa [psi.]	0~0.9 [0~131]						
Proof pressure	MPa [psi.]	1.3 [189]						
Operating temperature range	°C [°F]	5~60 [41~140]						
Materials	Body	Brass						
	Element	Sintered brass (Porous rating of air pass section: 60 μm)						
Effective area	mm ² [Cv]	3.5 [0.194]	17 [0.94]	42 [2.33]	50 [2.78]	56 [3.11]	103 [5.72]	199 [11.1]
Noise suppressing effect	dB	14	1	6	13	8	15	12
Mass	g [oz.]	3 [0.11]	52 [1.83]	53 [1.87]	55 [1.94]	61 [2.15]	150 [5.29]	335 [11.82]
Sales unit		One pc.						

Dimensions (mm)

● 150-30A

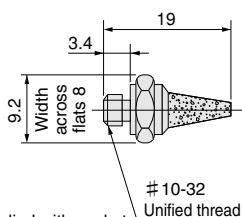

- Supplied with gasket

● KM-1 ~ KM-8

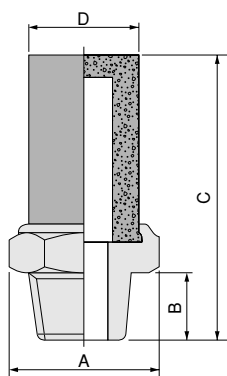

Code Model	Port size R	A (Width across flats)	B	C	D
KM-1	1/8	24 (21)	9	48	17.5
KM-2	1/4		10	49	
KM-3	3/8		12	51	
KM-4	1/2		15	65	
KM-6	3/4	36 (32)	20	80	23.5
KM-8	1	52 (46)	20	80	37

Caution: In normal conditions, use this muffler screwed into a valve exhaust port. Avoid using the muffler where heavy flow impact can occur, such as for passing of exhaust air from a quick exhaust valve.

EXHAUST FILTERS

Rc1/4~Rc1

- Eliminate oil from exhaust air, and also reduce noise.
- Create a clean and quiet environment.

Symbol



Specifications

Item	Model	EF300	EF600	EF800
Port size	Rc	1/4, 3/8	3/8, 1/2	3/4, 1
Maximum processed flow rate ℓ/min [ft ³ /min.] (ANR)		300 [10.6]	1000 [35.3]	3000 [106]
Oil mist recovery rate	%	99.9 or more		
Filtration rating	μm	0.3		
Mass	kg [lb.]	0.22 [0.49]	0.39 [0.86]	0.55 [1.21]
Attachments	Bracket	Standard attachments		

Order Codes

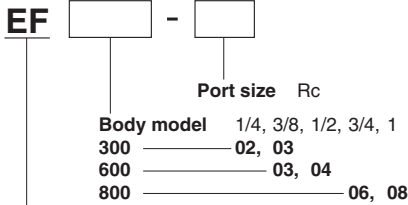

Exhaust filter

● Order codes for bracket only

For EF300 **8-30C**

For EF600 **8-60C**

For EF800 **8-80C**

Noise Suppressing Effect

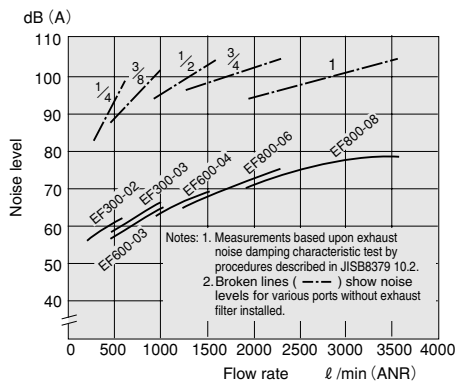

Inner Construction and Major Parts

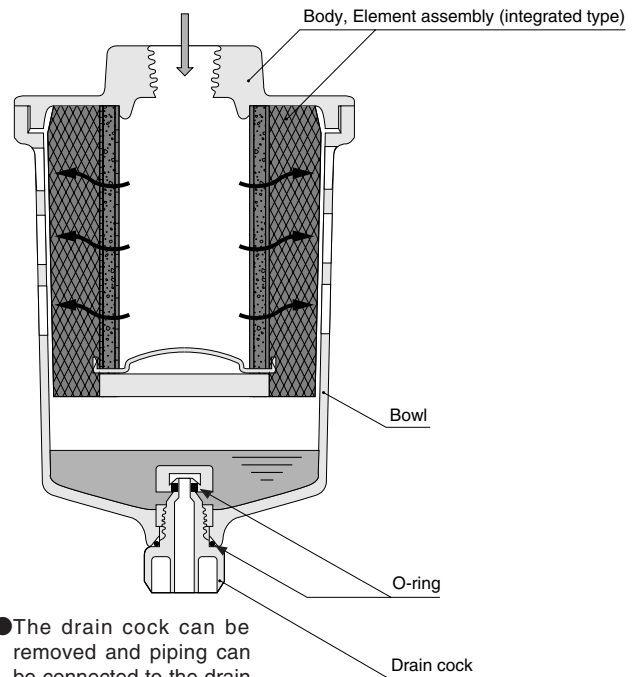

- The drain cock can be removed and piping can be connected to the drain port. Use the R1/4 fitting in that case.

Flow Rate Characteristics

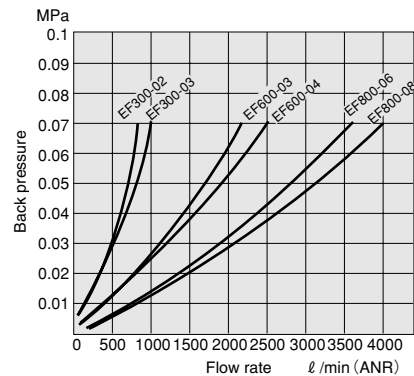

1MPa = 145psi. 1 ℓ/min = 0.0353ft³/min.

Dimensions (mm)

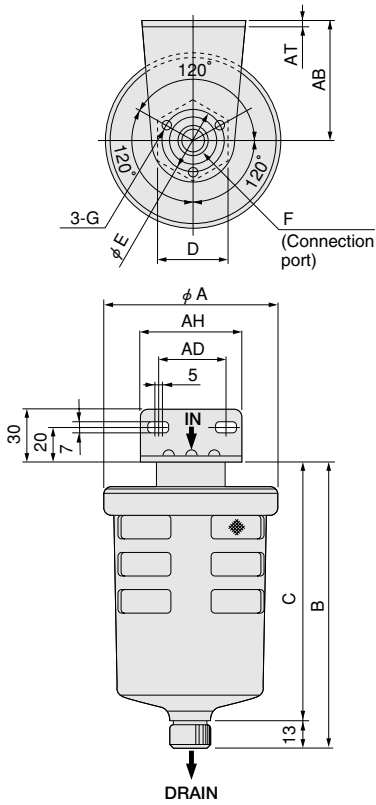

Model	Code	A	B	C	D	E	F	G	AB	AD	AH	AT
EF300-02		75	117	104	30	26	Rc1/4	M3×0.5 Depth 7.5	55	30	50	2.5
EF300-03	Rc3/8											
EF600-03		101	164	151	41	38	Rc3/8	M4×0.7 Depth 10	70	40	60	3.2
EF600-04	Rc1/2											
EF800-06		116	194	181	50	46	Rc3/4	M4×0.7 Depth 10	80	50	70	3.2
EF800-08	Rc1											

Selection Reference Graph

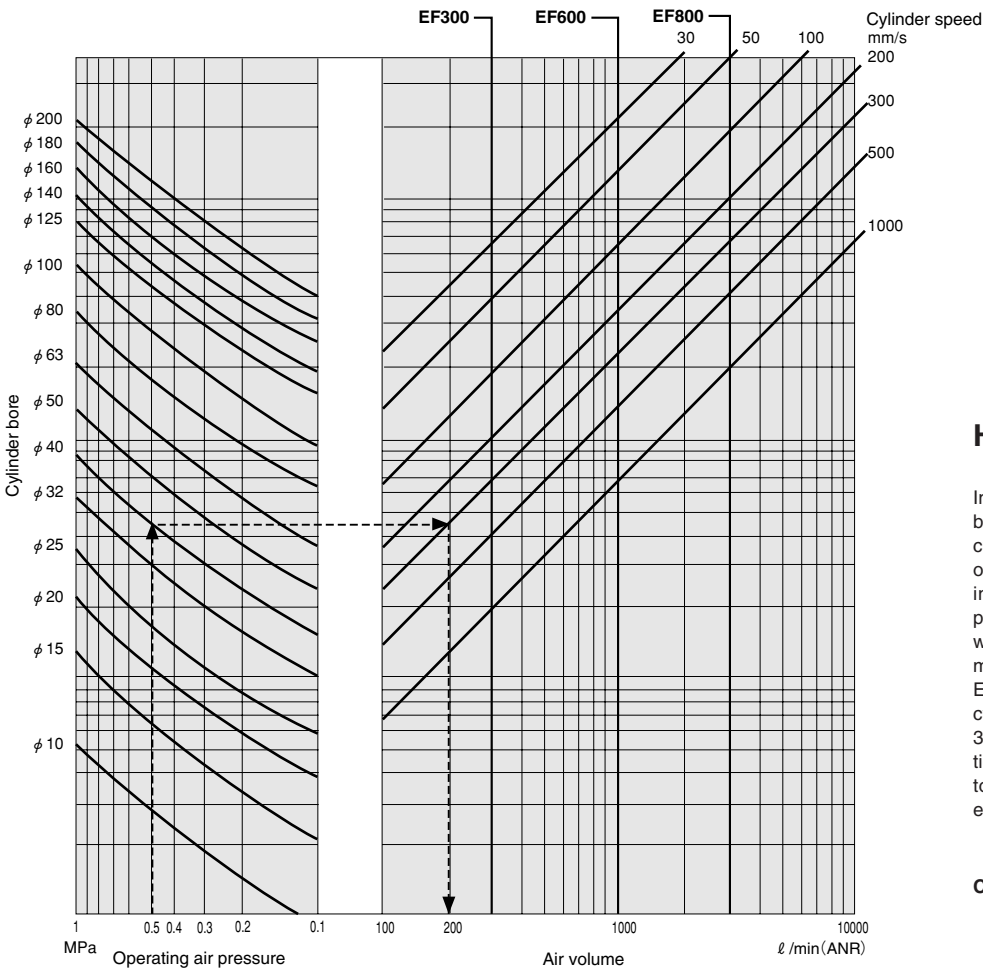

1 MPa = 145psi.
 1 l/min = 0.0353ft³/min.
 100mm/s = 0.328ft./sec.

How to read the graph

In the graph on the left, find the intersection between the operating air pressure and the cylinder bore, and then move horizontally over to the graph on the right to find the intersection with cylinder speed. Use this point to select the exhaust filter model type, where the point should be on the left of the model line.

Example shows, for air pressure of 0.5MPa, cylinder bore of φ 40, and cylinder speed of 300mm/s. With multiple cylinders applications, select a model type that ensures that total air volume is less than the maximum exhaust filter's processing capability.

Caution: Air volume in the graph on the right includes a slight margin beyond the air volume of the cylinder by adding the air volume of the piping.

AIR-HYDRO CONVERTERS

- No hydraulic unit means no vibration and more precise speed control without pulsation.
- Use compact and lightweight stainless tubes. Optimum for operating Slim Low Hydraulic Cylinders of size ϕ 20 to ϕ 40.
- Equipped with oil level marker for easy checking of oil volume.

Symbol

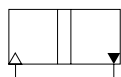

Specifications

Item	Model	AHC□×□
Maximum operating pressure	MPa [psi.]	0.9 [131]
Proof pressure	MPa [psi.]	1.3 [189]
Operating temperature range	°C [°F]	5~60 [41~140]

Order Codes

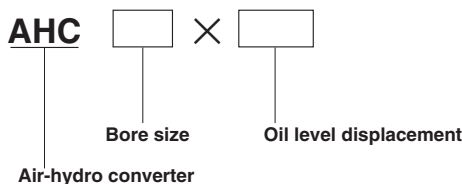

Bore size and Oil Level Displacement

Bore size	Standard oil level displacement				Maximum oil level displacement	Maximum available oil level displacement
	50	100	200	300		
32	50	100	200		300	750
40	50	100	200		400	
50	50	100	200	300	500	

Mass

Bore size mm	Oil level displacement mm				Additional mass for each additional 1mm [0.04in.] over the standard oil level displacement
	50	100	200	300	
32	0.280 [0.617]	0.313 [0.690]	0.378 [0.833]	(0.443) ([0.977])	0.00065 [0.023oz.]
40	0.405 [0.893]	0.446 [0.983]	0.527 [1.162]	(0.608) ([1.340])	0.00081 [0.029oz.]
50	0.655 [1.444]	0.719 [1.585]	0.846 [1.865]	0.937 [2.066]	0.00127 [0.045oz.]

Recommended Hydraulic Oil

For the hydraulic oil, use a petroleum-based hydraulic oil, or turbine oil with antifoaming additive. (ISO VG22~100 equivalent)
Avoid using incombustible hydraulic oil, spindle oil, or machine oil.

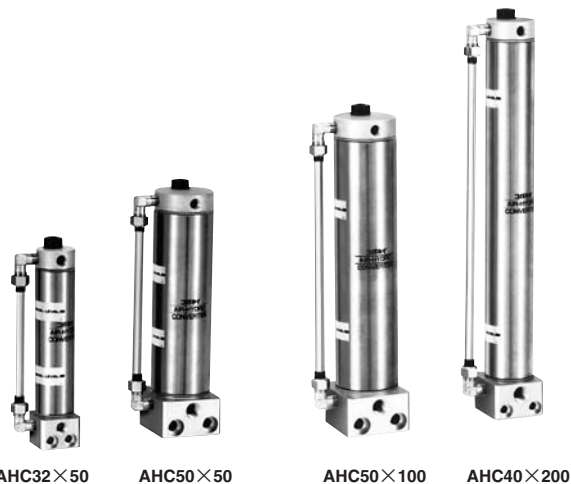

Inner Construction and Major Parts

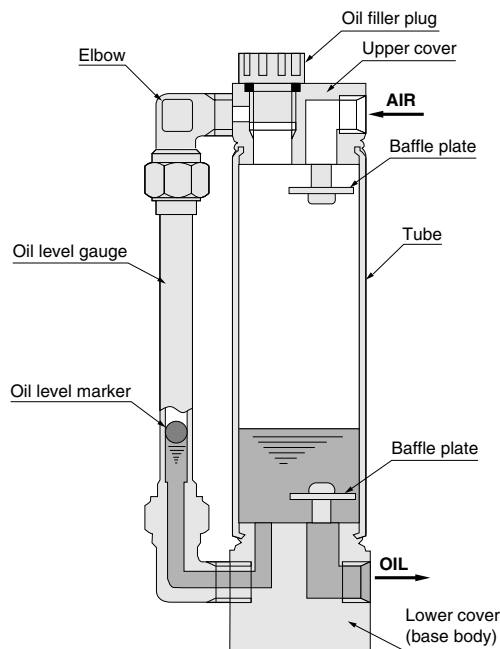

Major Parts and Materials

Parts	Materials
Tube	Stainless steel
Upper cover	Aluminum alloy
Lower cover	
Baffle plate	Mild steel
Oil level gauge	Hard nylon tube
Oil filler plug	Plastic
Elbow	Brass (nickel plated)

AIR-HYDRO CONVERTERS, AIR BLEEDERS

Selection Guideline

● Precautions for selection

- When using the converter, restrict the cylinder load ratio to 50% or less. In addition, use a hydraulic line connected on both cylinder ports to prevent intrusion of air.
- Select a converter bore that is one size larger than the cylinder bore. This will reduce roiling during fluid level movement, as well as reduce the intrusion of air bubbles.
- The converter's oil volume should be 50% greater than the cylinder's volume.
- Select a converter that will keep the rate of oil level rise as slow as possible. The maximum allowed speed of oil level rise is 200mm/s. Exceeding this rate could result in oil spraying out.

● Selection procedure

- First, check the cylinder bore and speed to determine the converter bore. The converter's maximum allowed rate of oil level rise is 200mm/s. (Graph 1)
- Next, use the cylinder bore and stroke to determine the converter's oil level displacement. (Graph 2)

Graph 1: Quick check for oil level increase rate in converter

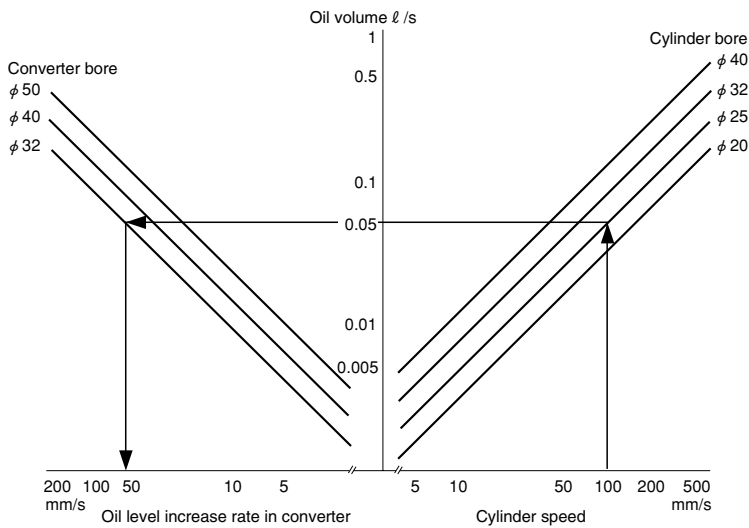

1 $\ell / \text{min} = 0.0353 \text{ft}^3 / \text{min}$.
1 mm/s = 0.0394 in./sec.

Example: With a cylinder bore size of 25 mm and a speed of 100 mm/s, selection of a converter with bore of 32mm will result in an oil level increase rate of about 60mm/s.

Graph 2: Quick check for converter oil level displacement

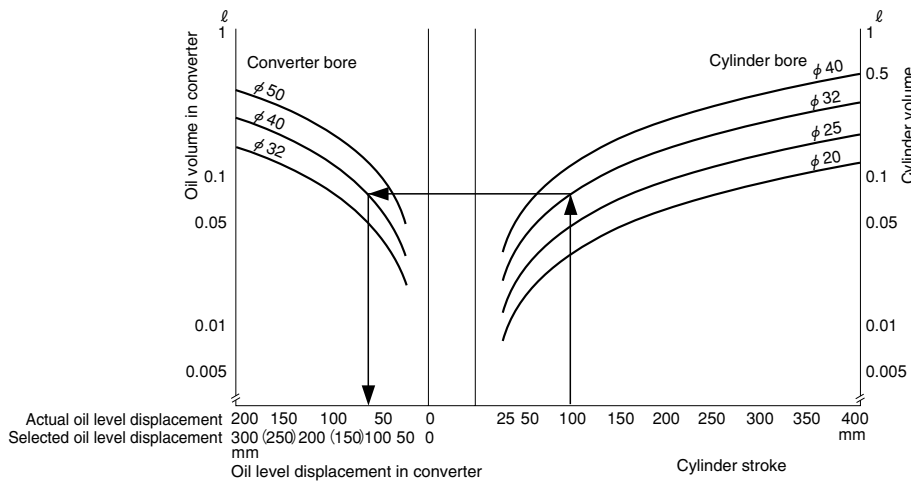

Example: With a cylinder bore size of 32mm and a stroke of 100mm, selection of a converter bore of 40mm will result in actual oil level displacement of about 65mm. In this case, select a converter with oil level displacement of 100mm.

● Cylinder volume

ℓ [ft³]

Cylinder bore mm [in.]	Stroke mm [in.]										
	25 [0.98]	50 [1.97]	75 [2.95]	100 [3.94]	125 [4.92]	150 [5.91]	200 [7.87]	250 [9.84]	300 [11.8]	350 [13.8]	400 [15.7]
20 [0.79]	0.0079 [0.00028]	0.0157 [0.00055]	0.0236 [0.00083]	0.0314 [0.00111]	0.0393 [0.00139]	0.0471 [0.00166]	0.0628 [(0.00222)]	0.0785 [(0.00277)]	0.0942 [(0.00333)]	0.1099 [(0.00388)]	0.1256 [(0.00443)]
25 [0.98]	0.0123 [0.00043]	0.0245 [0.00086]	0.0368 [0.00130]	0.049 [0.00173]	0.0613 [0.00216]	0.0735 [0.00259]	0.098 [0.00346]	0.1225 [(0.00432)]	0.147 [(0.00519)]	0.1715 [(0.00605)]	0.196 [(0.00692)]
32 [1.26]	0.0201 [0.00071]	0.0402 [0.00142]	0.0602 [0.00213]	0.0803 [0.00283]	0.1004 [0.00354]	0.1206 [0.00426]	0.1608 [0.00568]	0.2008 [(0.00709)]	0.2409 [(0.00850)]	0.2811 [(0.00992)]	0.3212 [(0.01134)]
40 [1.57]	0.0314 [0.00111]	0.0628 [0.00222]	0.0942 [0.00333]	0.1256 [0.00443]	0.157 [0.00554]	0.1884 [0.00665]	0.2512 [0.00887]	0.314 [0.01108]	0.3768 [0.01330]	0.4396 [(0.01552)]	0.5024 [(0.01773)]

Note: Figures in parentheses () show cylinder volume for non-standard strokes.

● Air-hydro converter volume

ℓ [ft³]

Converter bore mm [in.]	Oil level displacement mm [in.]						
	50 [1.97]	100 [3.94]	(150 [5.91])	200 [7.87]	(250 [9.84])	300 [11.8]	400 [15.7]
32 [1.26]	0.0402 [0.00142]	0.0803 [0.00283]	(0.1205) [(0.00425)]	0.1606 [0.00567]	(0.2008) [(0.00709)]	(0.2409) [(0.00850)]	(0.3212) [(0.01134)]
40 [1.57]	0.0628 [0.00222]	0.1256 [0.00443]	(0.1884) [(0.00665)]	0.2512 [0.00887]	(0.314) [(0.01108)]	(0.3768) [(0.01330)]	(0.5024) [(0.01773)]
50 [1.97]	0.0982 [0.00347]	0.1963 [0.00693]	(0.2945) [(0.01040)]	0.3926 [0.01386]	(0.4908) [(0.01733)]	0.5889 [0.02079]	(0.7852) [(0.02772)]

Note: Figures in parentheses () show made to order products.

Dimensions (mm)

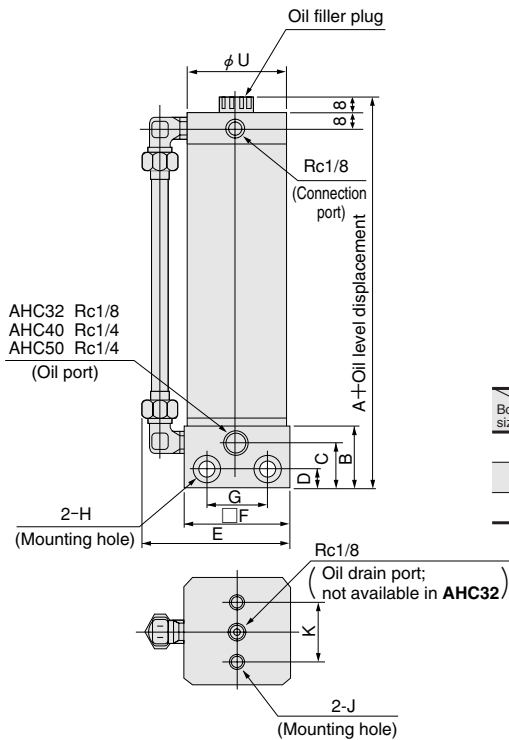

Bore size	Code	A	B	C	D	E	F	G	H	J	K	U
		32	117	26	18	7	59	35	16	φ 6.6 Counterbore φ 11 Depth6	M6X1 Depth6	14
40	149	29	19.5	7	67	45	26	φ 6.6 Counterbore φ 11 Depth6	M6X1 Depth6	26	41.6	
50	156	32	22.5	9	71	55	32	φ 9 Counterbore φ 14 Depth8	M8X1.25 Depth9	30	52	

Handling Instructions and Precautions

● Oil filling procedure

● If converter is at a higher position than cylinder

1. Move the cylinder piston to the stroke end in the oil supply side, and supply oil until it reaches the top of the oil level gauge. (a, b)
If an air bleeder is installed, supply oil while pressing down the air bleeder button until all air has escaped.
2. Open the speed controller all the way, and operate the cylinder without load for about 100 operation cycles (c). If oil appears to be needed, use the procedure in 1 above to supply oil until it reaches the top of the oil level gauge. (d, e)

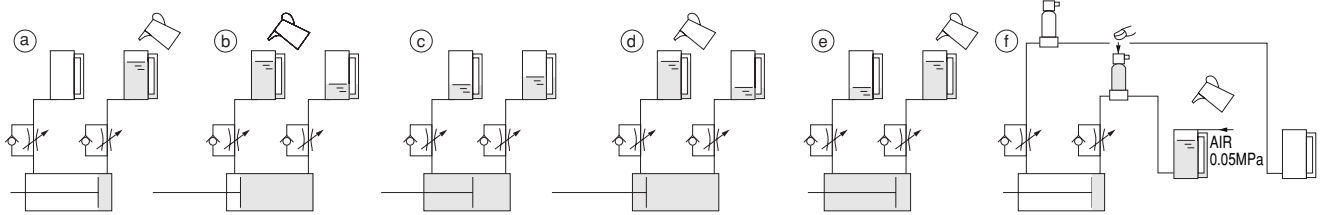

※Mount the air bleeder to the highest position in piping.

● If converter is at a lower position than cylinder

- (Because of the difficulty in performing air bleed operations, avoid this mounting position as much as possible.)
1. Move the cylinder piston to the stroke end in the oil supply side, supply oil until it reaches the top of the oil level gauge, and screw and seal the oil filler plug. Then apply 0.05MPa [7psi.] of air pressure via the converter's air port, and repeatedly press down on the air bleeder's button until all air has escaped. (f)
 2. Open the speed controller all the way, and operate the cylinder without load for about 100 operation cycles. If oil appears to be needed, use the procedure in 1 above to supply oil until it reaches the top of the oil level gauge.

● Precautions

- Mount the converter in a vertical position. In addition, installing in a position higher than the cylinder will ease air bleed and oil supply operations.
- For piping, use fittings and tubes with reasonably similar bore sizes. This will limit the occurrence of air bubbles.
- For piping operations, always flush out the piping to remove any foreign material. In addition, anaerobic liquid sealant is recommended for sealing

- the fittings. Avoid the use of sealing tape if at all possible, since it could cause clogging.
- After piping operations, apply air pressure to the system to check for leaks before supplying oil.
- For the oil supplied to the converter, always use the recommended hydraulic oil.

AIR BLEEDERS

- Remove air bubbles accumulating inside the piping of a low pressure hydraulic circuit, to enable stable speed control.
- The transparent body allows quick visual confirmation of air bubble occurrence.
- Push-type air bleeder button supports simple handling.
- The bleed port is equipped with a fitting, to avoid contamination of surrounding areas.

Symbol

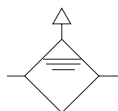

Specifications

Item	Model	AHB150-□-□
Maximum operating pressure	MPa [psi.]	0.9 [131]
Proof pressure	MPa [psi.]	1.3 [189]
Operating temperature range	°C [°F]	5~60 [41~140]
Mass	g [oz.]	160 [5.64]
Materials	Body	Polycarbonate
	Piping part	Aluminum die-casting

Order Codes

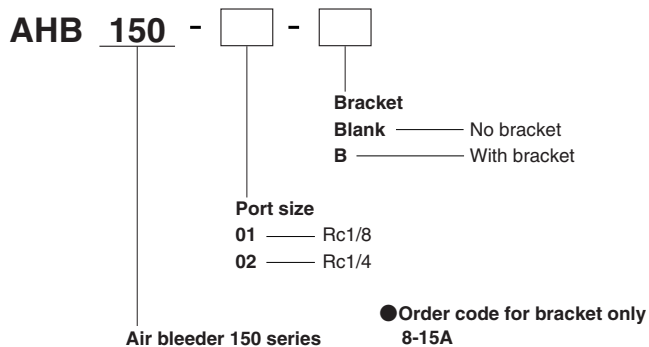

Inner Construction and Major Parts

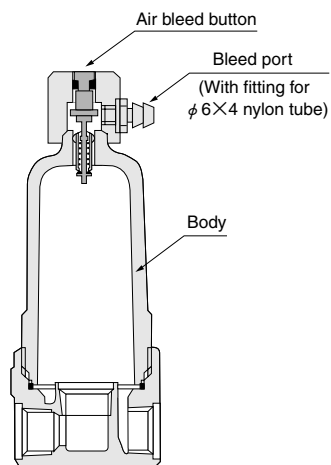

Dimensions (mm)

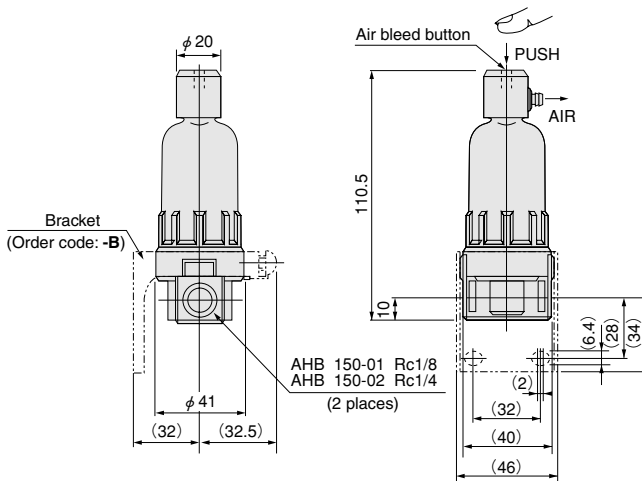

Handling Instructions and Precautions

● Mounting

- Mount the air bleeder in a vertical position.
- For the most efficient air bleed operation, mount the unit either directly onto the cylinder, or at the highest position in the piping system.
- If the piping system has an area where air bubbles tend to accumulate, mount the unit at that location.

● Bleeding the air

- Whenever air pressure is applied to the converter, press the air bleed button to bleed out the air.

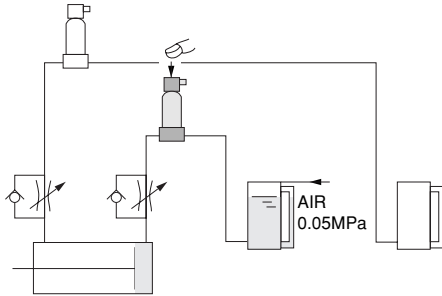

- For the oil supplied to the converter, always use the recommended hydraulic oil. For recommended hydraulic oil, see p.554.
- The air bleeder body is made of polycarbonate. Avoid use in locations where the ambient atmosphere contains organic solvents, etc.

HOLDERS AND COLUMN TUBES

alpha series



Holders and Column Tubes are:

- Highly reliable fixtures in firm support of actuator operations.
- High quality support equipment with flexible adaptability to all design and assembly requirements in mechanical devices.
- Column Tubes come in three types and nine variations capable of heavy-load operations.

Order Codes

● Column tube

PHP



Outer diameter of the tube × overall length

Column tube

■ Outer diameter of the tube and overall length

		mm	
Outer diameter of the tube	Overall length		
40 [1.575in.]	300, 450, 600		
54 [2.126in.]	450, 600, 750		
74 [2.913in.]	600, 750, 900		

● Holder



Outer diameter of the using tube

Holder basic model

PHU — Union type

PHB — Base type

40	φ 40 [1.575in.]
54	φ 54 [2.126in.]
74	φ 74 [2.913in.]

Dimensions (mm)

Column tube Materials: Mild steel (nickel plated)

● PHP

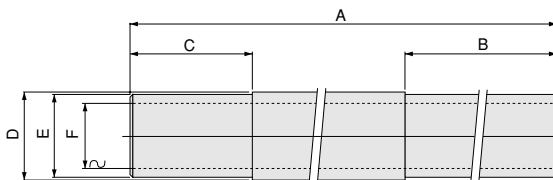

■ Mass

Type	Overall length mm	g [oz.]				
		300	450	600	750	900
PHP40	900 [31.7]	1480 [52.2]	2290 [80.8]	—	—	—
PHP54	—	2970 [104.8]	4410 [155.6]	5700 [201.1]	—	—
PHP74	—	—	6300 [222.2]	8090 [285.4]	9900 [349.2]	—

Code	A					B					C	D	E	F
	Model	Overall length	300	450	600	750	900	300	450	600				
PHP40	300	450	600	—	—	Fully machined*1	Fully machined*1	300	—	—	70	φ 42.7	φ 40h8 ^{0.039}	φ 32.7
PHP54	—	450	600	750	—	—	Fully machined*2	300	300	—	80	φ 57	φ 54h8 ^{0.046}	φ 43
PHP74	—	—	600	750	900	—	—	300	300	300	120	φ 76.3	φ 74h8 ^{0.046}	φ 62.3

※1: Fully machined at φ 40h8^{0.039}.

※2: Fully machined at φ 54h8^{0.046}.

Holder Materials: aluminum alloy casting (black painted)

● PHU (Union type)

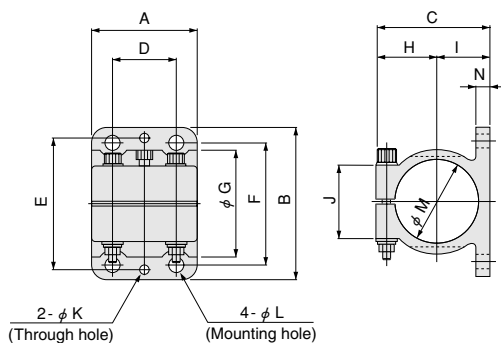

● PHB (Base type)

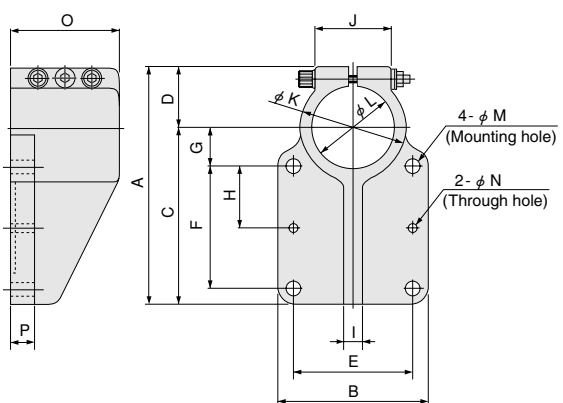

■ Mass g [oz.]

Model	Mass
PHU40	320 [11.3]
PHU54	510 [18.0]
PHU74	1170 [41.3]

■ Mass g [oz.]

Model	Mass
PHB40	440 [15.5]
PHB54	850 [30.0]
PHB74	2280 [80.4]

Code	A	B	C	D	E	F	G	H	I	J	K	L	M	N
PHU40	60	80	62	40	68	60	54	32	30	40	4	7	40H8 ^{+0.046} ₀	8
PHU54	70	100	75	40	86	80	70	40	35	50	5	9	54H8 ^{+0.046} ₀	10
PHU74	90	140	100	60	120	110	94	53	47	70	6	11	74H8 ^{+0.015} ₀	12

Code	A	B	C	D	E	F	G	H	I	J	K	L	M	N	O	P
PHB40	112	80	80	32	60	50	20	25	10	40	54	40H8 ^{+0.039} ₀	7	4	60	12
PHB54	155	100	115	40	80	80	25	40	12	50	70	54H8 ^{+0.046} ₀	9	5	70	15
PHB74	203	140	150	53	110	105	30	55	20	70	94	74H8 ^{+0.046} ₀	11	6	110	20

HOLDERS AND COLUMN TUBES

Strength and Simplicity

As fixtures required in production line operations, Koganei Holders and Column Tubes are high quality support equipment offering flexible adaptability to all design and assembly requirements in mechanical devices.



DB1, DB2, DB3 Column tubes

- Materials : Mild steel (zinc plated)
- Mass: 1.6kg [3.5lb.] (DB1), 2.5kg [5.5lb.] (DB2), 3.3kg [7.3lb.] (DB3)

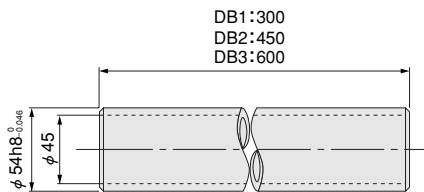

DH1 Holder

- Material: aluminum alloy casting (black painted)
- Mass: 0.5kg [1.1lb.]

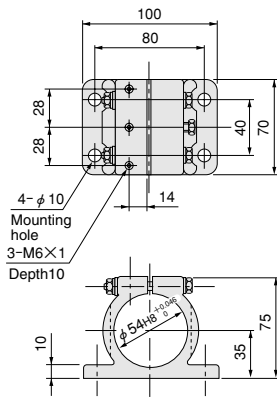

DH2 Holder

- Material: aluminum alloy casting (black painted)
- Mass: 0.8kg [1.8lb.]

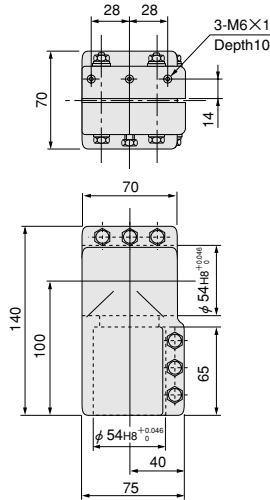

DH3 Holder

- Material: aluminum alloy casting (black painted)
- Mass: 0.8kg [1.8lb.]

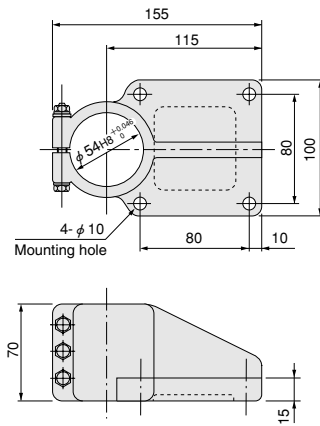

DH4 Holder

- Material: aluminum alloy casting (black painted)
- Mass: 0.6kg [1.3lb.]

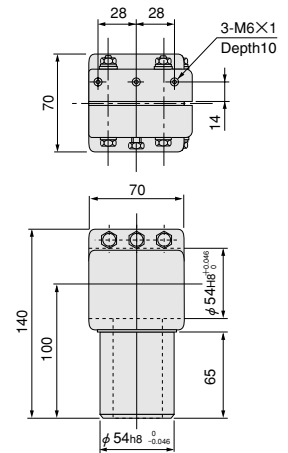

AIR INDICATORS

M5×0.8, R1/8 (M5×0.8)

- Air Indicators change colors to display the presence or absence of air pressure in pneumatic circuits.
- Air Indicators enable checks of pressurized lines, and of operating status and completion of operation.
- Air Indicators have construction to completely change colors, with sharply contrasting indication.

Symbol



Specifications

Item	Model	KIS-R	KIS-G	KIL-R	KIL-G
Port size		M5×0.8		R1/8 and M5×0.8 (female thread)	
Media		Air			
Operating pressure range	MPa [psi.]	0.15~0.9 [22~131]		0.1~0.7 [15~102]	
Proof pressure	MPa [psi.]	1.3 [189]			
Operating temperature range	°C [°F]	0~60 [32~140]			
Maximum operating frequency	Hz	5		3	
Lubrication		Required			
Color indication	No air pressure	None	None	Green	Red
	Under air pressure	Red	Green	Red	Green
Body material		Brass		Aluminum alloy	
Mass	g [oz.]	5 [0.18]		86 [3.03]	

Sales unit

KIS is sold in sets of 5 pcs. When ordering, enter "one" for a set of 5 pcs.

KIL is sold as 1 pc.

Dimensions (mm)

● KIS

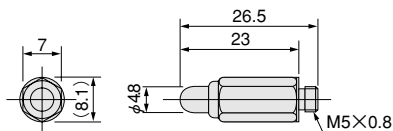

● KIL

