



CAD drawing data catalog is available



KOGANEI

ACCESSORIES GENERAL CATALOG

AIR TREATMENT, AUXILIARY, VACUUM,
AND FLUORORESIN PRODUCTS

PLACHAIN DUCTS CONTENTS

Features	603
Specifications, Order Codes	604
Mounting Bracket Specifications, Order Codes	605
Dimensions of Fully Open Type	606
Dimensions of Fully Covered Type	608
Handling Instructions and Precautions	609
Selection Guideline	610



Caution

Before use, be sure to read the "Safety Precautions" on p. 49.

PLACHAIN DUCTS

PU Series, PO Series

Smoothly protect and guide the tubes and cables in the movable areas of equipment.

The plachain duct, made of lightweight, highly durable engineering plastic, quietly and smoothly follows the motions of the movable areas of high-performance industrial robots, machine tools, transfer equipment, etc. It combines and arranges tubes and cables, with protection and guidance functions that prevent twisting and bending, to greatly improve equipment's safety and maintenance.

PU series

The fully open type facilitates easy confirmation of internal situation. In addition, because the flap can be opened to either the left or right, replacement operating efficiency for tubes and cables is also greatly improved.

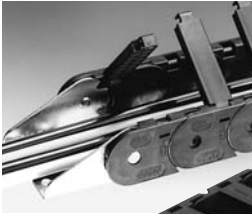

PO series

Protecting tubes and cables from dust, etc. this smart-looking fully covered type uses the same flap as the PU series, enabling it to be opened from either left or right.

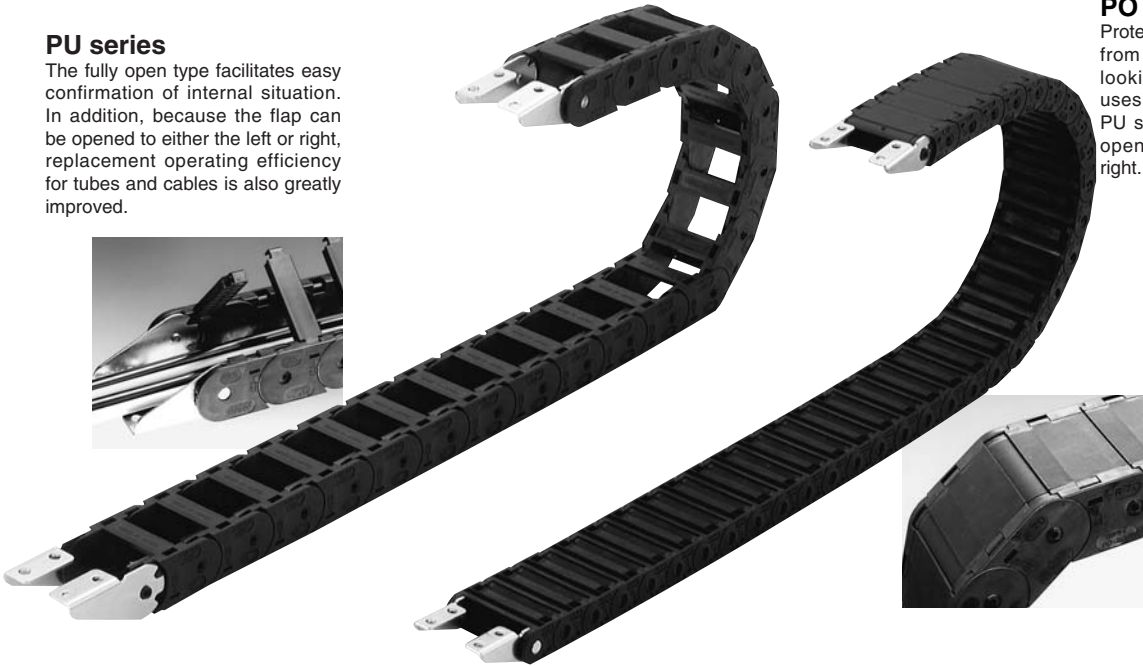

Horizontal slide mounting I
(Upper side slide)

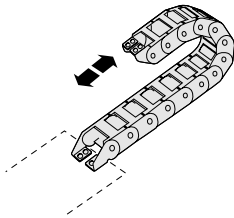

Vertical slide mounting I
(Inverted U-shape)

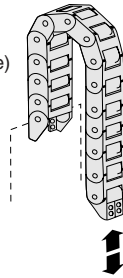

Opposed slide mounting

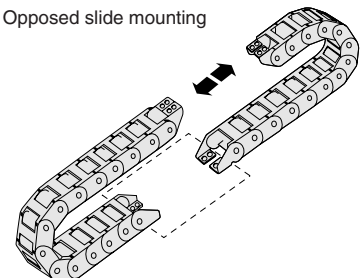

Horizontal slide mounting II
(Lower side slides)

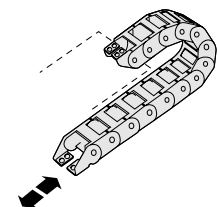

Vertical slide mounting II
(U-shape)

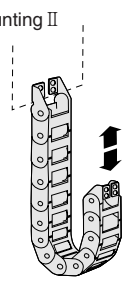

Complex slide mounting

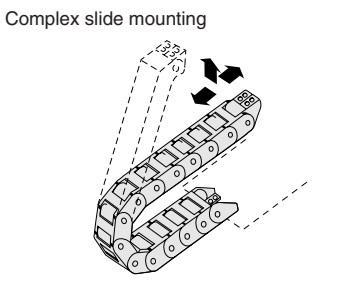

Specifications

Series	PU series						PO series			
Basic model	PU 202	PU 203	PU 204	PU 206	PU 306	PU 408	PO 204	PO 206	PO 408	
Minimum bending radius (R) mm [in.]	30 [1.18] 45 [1.77]		38 [1.50] 50 [1.97]		50 [1.97] 100 [3.94] 150 [5.91]		38 [1.50] 50 [1.97]		70 [2.76] 100 [3.94] 150 [5.91] 200 [7.87]	
Chain link cross section dimensions										
Note: The ϕ figures in the chain link show the maximum cable or tube outer diameter.										
Pitch mm [in.]	25 [0.98]		32 [1.26]		45 [1.77]		26 [1.02]		45 [1.77]	
Number of links (per 1m [3.28ft.])	40		32		23		39		23	
Maximum free span m [ft.]	0.75 [2.46]		1.0 [3.28]		1.5 [4.92]		0.75 [2.46]		1.5 [4.92]	
Maximum travel stroke m [ft.]	1.4 [4.59]		1.9 [6.23]		2.9 [9.51]		1.4 [4.59]		2.9 [9.51]	
Maximum cable and tube mass kg/m [lb./ft.]	0.6 [0.403]		1 [0.672]		4 [2.69] 5 [3.36]		1.25 [0.840]		5 [3.36]	
Maximum speed m/s [ft./sec.]	2.5 [8.20]		2.5 [8.20]		2.5 [8.20]		2.5 [8.20]		2.5 [8.20]	
Allowable cross section volume rate	Max. 60%									
Mass kg/m [lb./ft.]	0.25 [0.168]	0.26 [0.175]	0.5 [0.336]	0.56 [0.376]	0.64 [0.430]	1.1 [0.739]	0.5 [0.336]	0.6 [0.403]	1.36 [0.914]	
Operating temperature range °C [°F]	-10~80 [14~176]									
Materials	Nylon or PBT									
Environment conditions	Avoid use in acidic or alkali atmosphere, or in heated water.									
Allowable content volume ratio mm ² [in. ²]	Max. 118 [0.183]	Max. 168 [0.260]	Max. 168 [0.260]	Max. 336 [0.521]	Max. 634 [0.983]	Max. 853 [1.322]	Max. 172 [0.267]	Max. 328 [0.508]	Max. 870 [1.348]	

Remark: The figures below show the piping tube cross-section area (mm² [in.²]).

ϕ 4: 12.5 [0.0194] ϕ 6: 28.2 [0.0437] ϕ 8: 50.2 [0.0778] ϕ 10: 78.5 [0.1217] ϕ 12: 113 [0.175] ϕ 16: 201 [0.312]

Order Codes

● Complete chains (sales unit 1m)



Type	Size	Minimum bending radius
PU	202	30, 45
	203	30, 45
	204	38, 50
	206	38, 50
	306	50, 100, 150
	408	50, 75, 100, 150, 200
PO	204	38, 50
	206	38, 50
	408	70, 100, 150, 200

Mounting bracket for links with holes (fixed end)

- Blank — No mounting bracket
- HA — For attached facing outward (inside mounting holes)
- HB — For attached facing inward (inside mounting holes)
- HAE — For attached facing outward (outside mounting holes)
- HBE — For attached facing inward (outside mounting holes)

Mounting bracket on link side with pin (travel end)

- Blank — No mounting bracket
- PA — For attached facing outward (inside and outside combined use mounting holes)
- PB — For attached facing inward (inside and outside combined use mounting holes)

● Chain links (for add on : Sales unit one set)

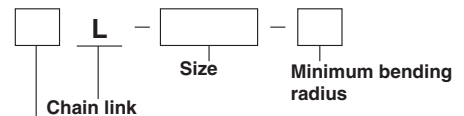

- Type
- PU—Fully open type
 - PO—Fully covered type

Mounting Bracket Specifications

Brackets for these two series can be used as mounting brackets for the **PU** series.

Mounting position variations

Mounting for link with pin (travel end)

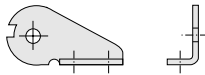

Mounting for link with hole (fixed end)

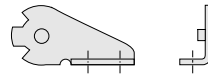

Mounting examples

Both travel and fixed ends are attached facing outward

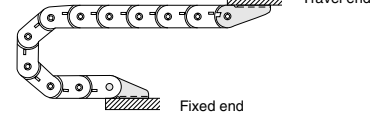

Both travel and fixed ends are attached facing inward

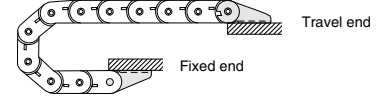

Travel end is attached facing inward, and fixed end is attached facing outward

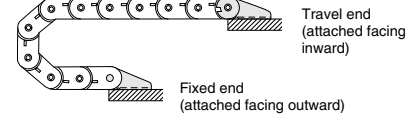

Travel end is attached facing outward, and fixed end is attached facing inward

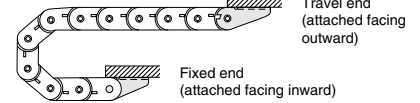

Mounting hole position variations

Inside mounting holes

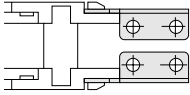

Outside mounting holes

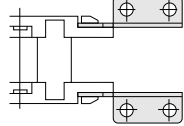

(-PA and -PB apply to inside and outside combined use mountings.)

Variations for secured surfaces

Attached facing outward

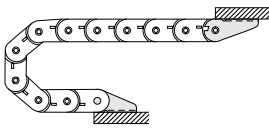

Attached facing inward

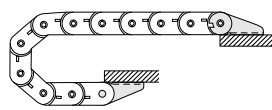

(Mounting dimensions are identical. The secured surface facings are on opposite sides.)

Mounting Bracket Order Codes

● Mounting bracket (For one end only, Sales unit one set)

In the table PUM-□-□ shows the models of the mounting brackets. Use the descriptions below to select the model.

1. Select type (PU or PO)
2. Select the size
3. Select what type of connection link (Travel end/Fixed end)
4. Select the facing direction of bracket (Inside mounting holes/Outside mounting holes)
5. Select the attaching direction of bracket (Attached facing outward/Attached facing inward)
6. Select the mounting bracket model

Mounting bracket model

Mounting bracket for link (link type)		Bracket with hole for travel end (link with pin)				Bracket with pin for fixed end (link with hole)				
Bracket facing direction		Inside mounting holes		Outside mounting holes		Inside mounting holes		Outside mounting holes		
Mounting bracket attaching direction		Attached facing outward	Attached facing inward	Attached facing outward	Attached facing inward	Attached facing outward	Attached facing inward	Attached facing outward	Attached facing inward	
Type	PU	202	PUM-202-PA	PUM-202-PB	PUM-202-PA	PUM-202-PB	PUM-202-HA	PUM-202-HA	PUM-202-HAE	PUM-202-HAE
		203								
		204	PUM-204-PA	PUM-204-PB	PUM-204-PA	PUM-204-PB	PUM-204-HA	PUM-204-HA	PUM-204-HAE	PUM-204-HAE
	PO	206								
		306	PUM-306-PA	PUM-306-PA	PUM-306-PA	PUM-306-PA	PUM-306-HA	PUM-306-HB	PUM-306-HAE	PUM-306-HBE
		408	PUM-408-PA	PUM-408-PA	PUM-408-PA	PUM-408-PA	PUM-408-HA	PUM-408-HB	PUM-408-HAE	PUM-408-HBE
		204	PUM-204-PA	PUM-204-PB	PUM-204-PA	PUM-204-PB	PUM-204-HA	PUM-204-HA	PUM-204-HAE	PUM-204-HAE
		206								
		408	PUM-408-PA	PUM-408-PB	PUM-408-PA	PUM-408-PB	PUM-408-HA	PUM-408-HB	PUM-408-HAE	PUM-408-HBE

Dimensions of Fully Open Type (mm)

● PU202, PU203

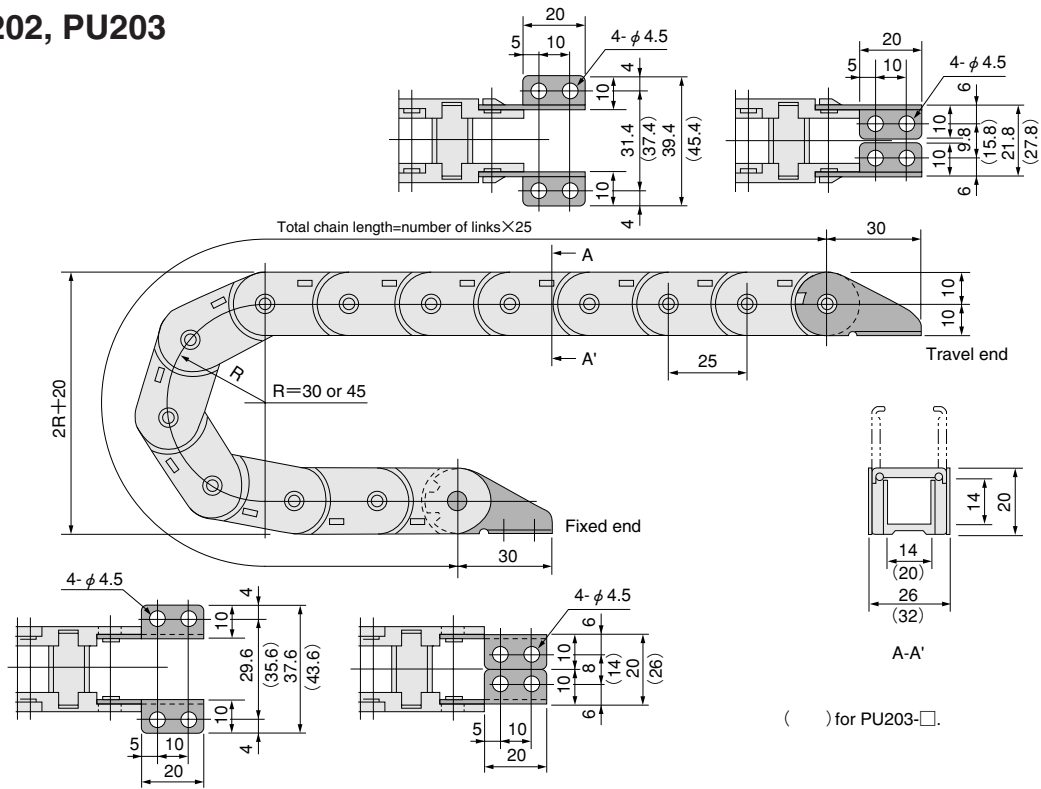

● PU204, PU206

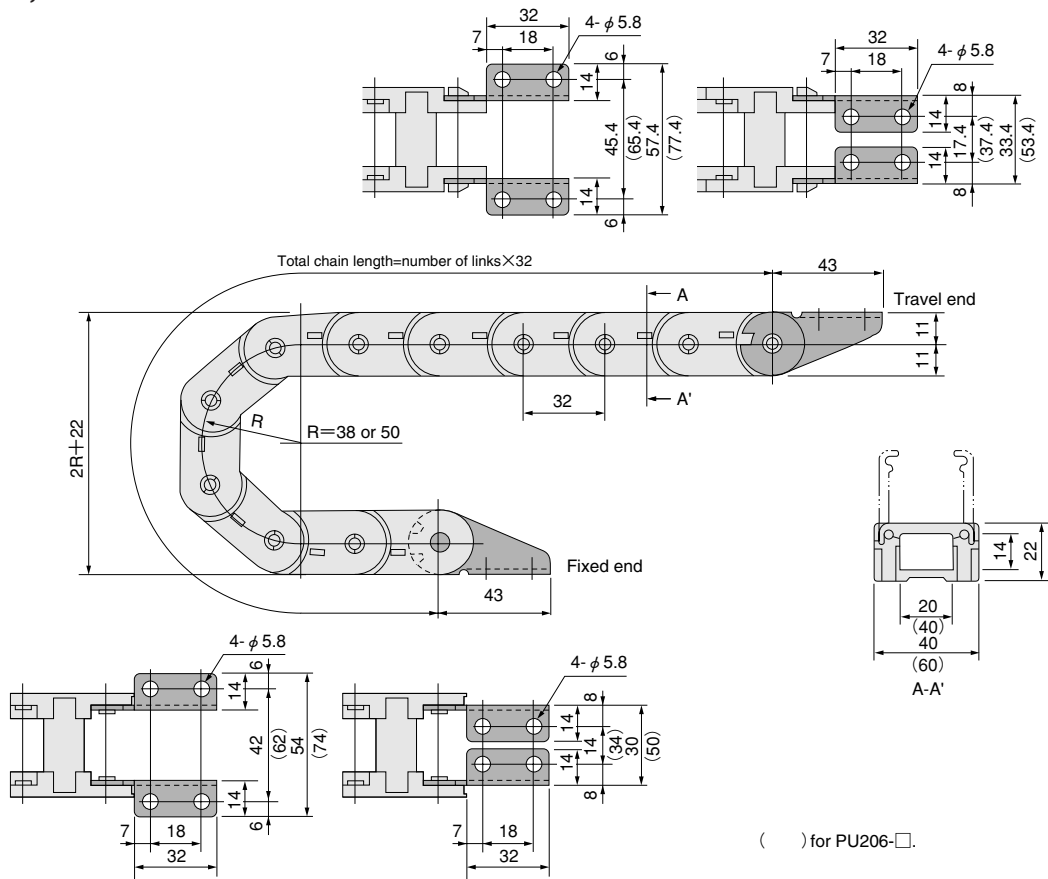

Dimensions of Fully Open Type (mm)

● PU306

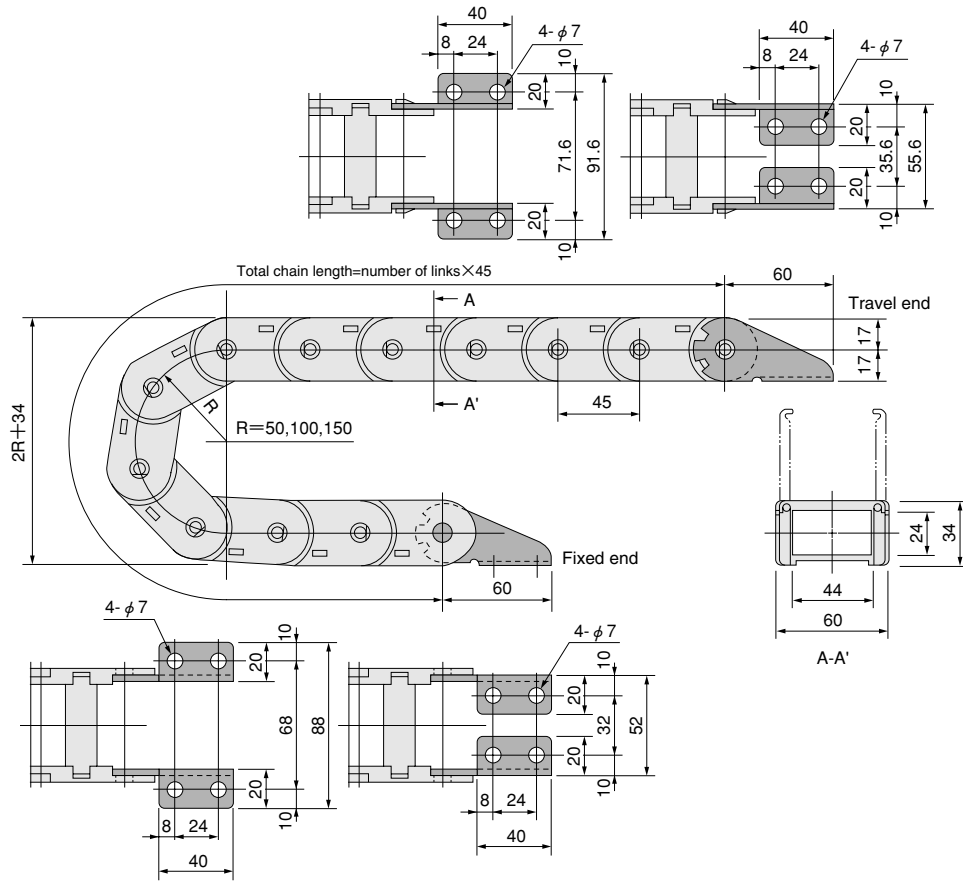

● PU408

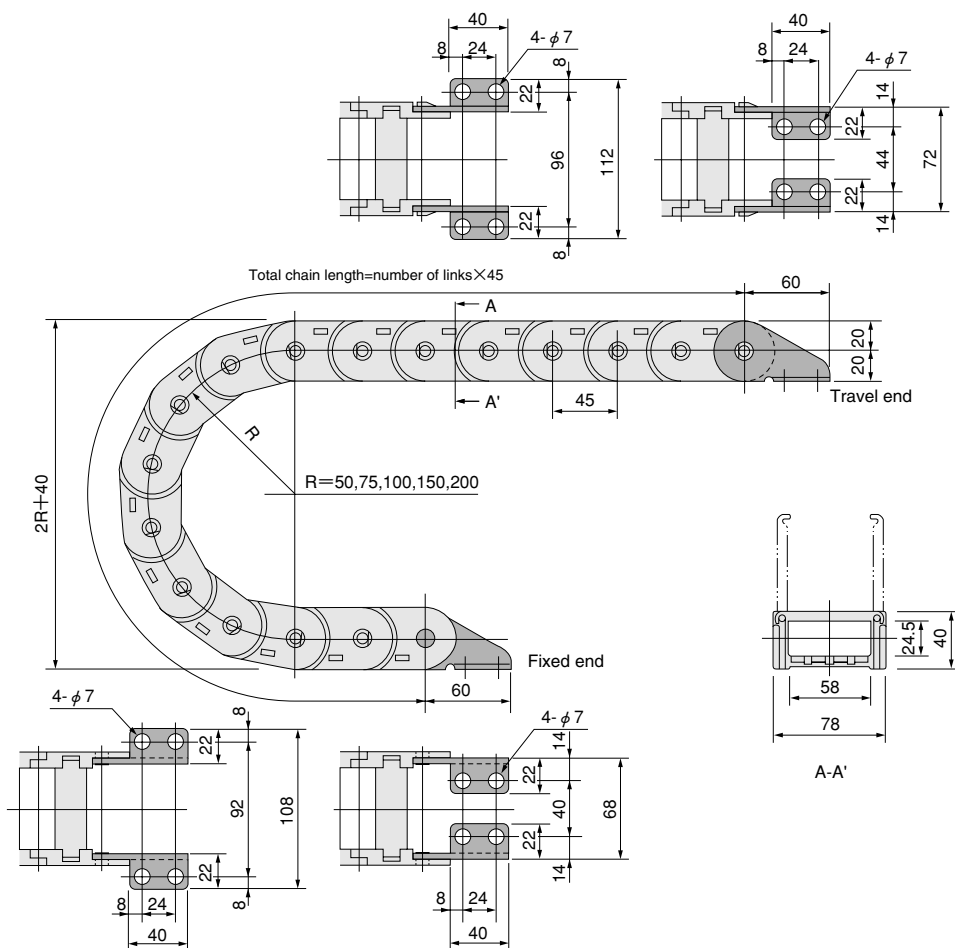

Dimensions of Fully Covered Type (mm)

● PO204, PO206

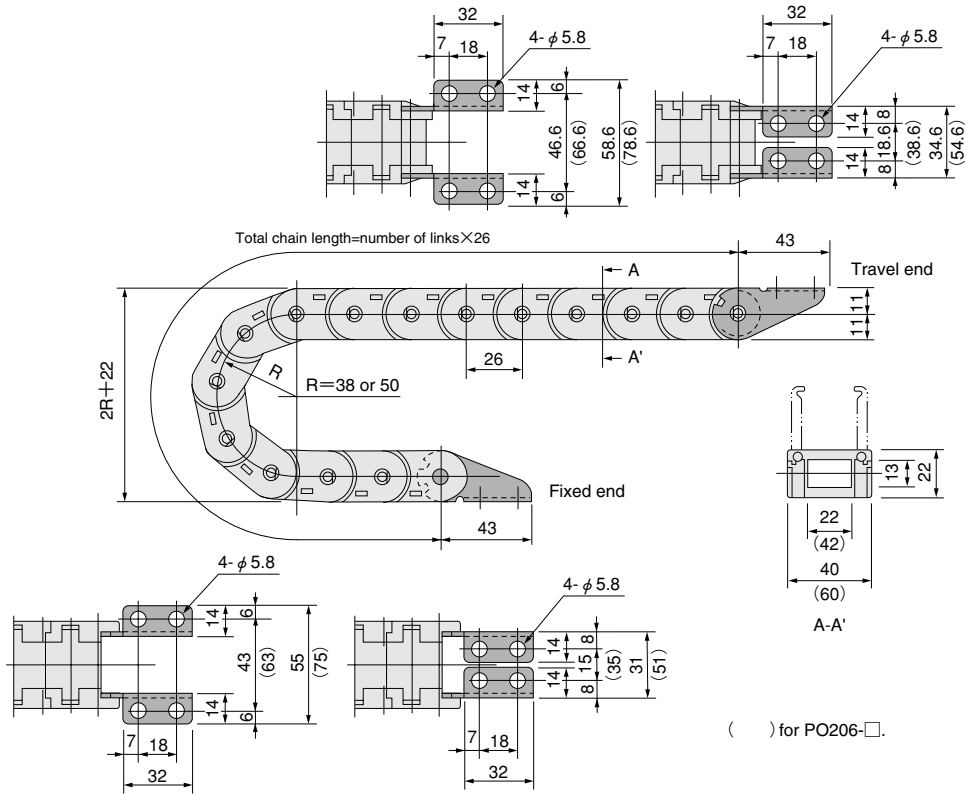

● PO408

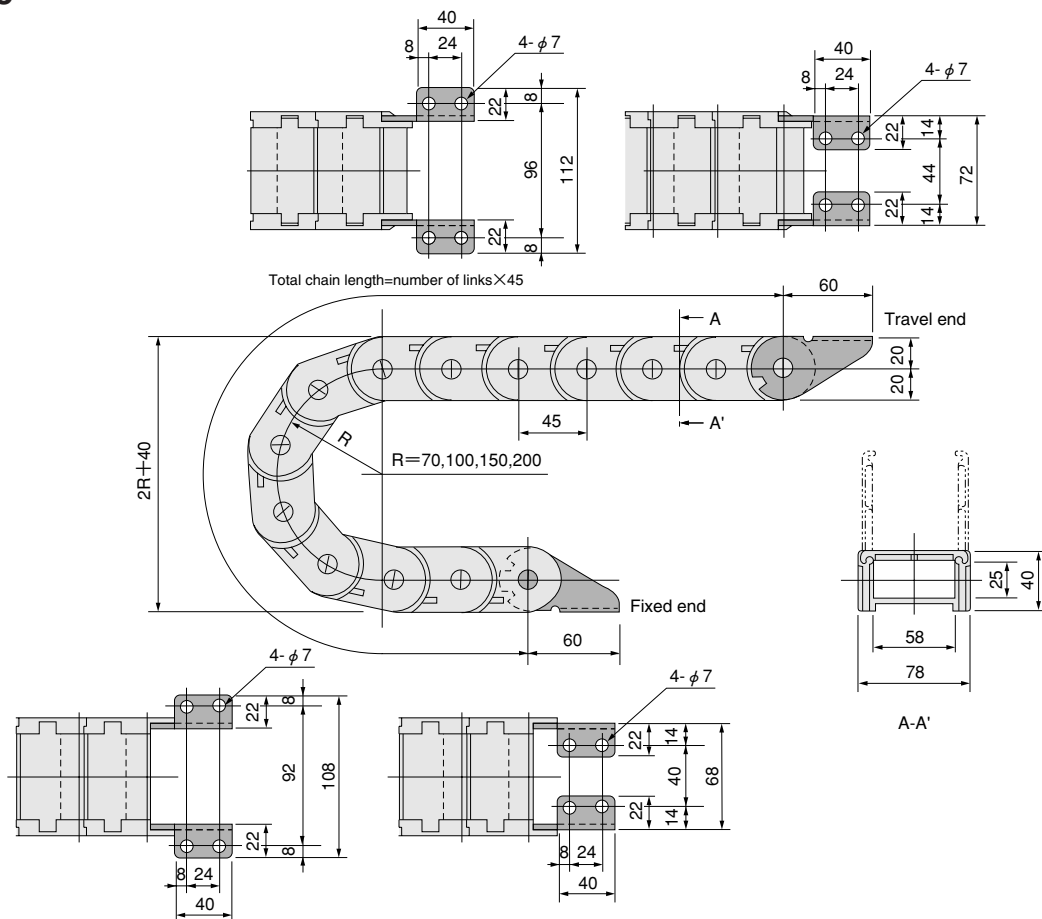

Handling Instructions and Precautions



Mounting

Calculating the Number of Links

Use the following equation to calculate the number of links.

$$n = \frac{\frac{S}{2} + \pi R + 2K}{P}$$

- n : Number of links (Rounded up to the nearest whole number.)
- S : Travel stroke (mm)
- R : Bending radius (mm)
- K : Margin (mm)
- P : Pitch (mm)

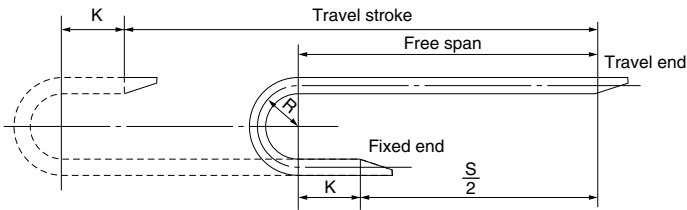

Series	R	K	πR	$\pi R + 2K$	P
PU202, 203	30	Min. 25	94.2	Min. 144.2	25
	45		141.3	Min. 191.3	
PU204, 206 PO204, 206	38	Min. 30	119.3	Min. 179.3	32
	50		157.0	Min. 217.0	
PU306, 408 PO408	50	Min. 50	157.0	Min. 257.0	45
	70		219.8	Min. 319.8	
	75		235.5	Min. 335.6	
	100		314.0	Min. 414.0	
	150		471.0	Min. 571.0	
	200	628.0	Min. 728.0		

Attaching the Mounting Brackets

Attach the mounting bracket with holes (P) on the travel end of plachain duct (link with pin), and attach the mounting bracket with pin (H) on the fixed end (link with hole) side. Insert the mounting bracket firmly into the link, and secure in place with mounting screws to prevent the body from twisting.

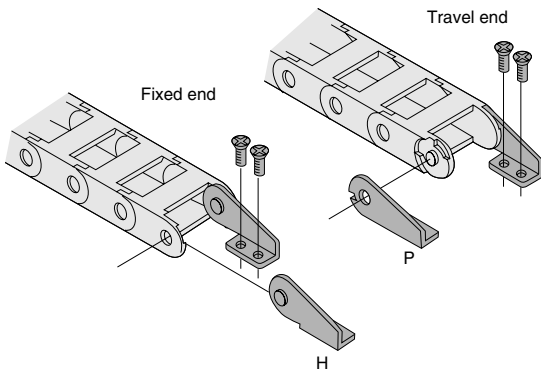

Link Connection and Separation

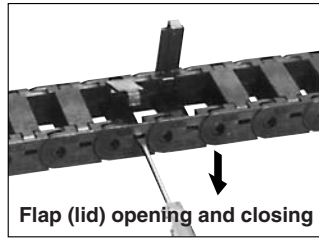

● Opening and closing the PU series (fully open type) flap (lid)

To open the flap, insert a flat blade screwdriver into the rectangular hole on either side of the link, and push up the flap hook by trying the principle of the lever. To close, use fingers to push the flap down.

Connection

First, open up the flaps on the two links to be connected, then align the links and push them together from both sides.

Separation

First, open up the flaps on the two links to be separated, then insert a flat blade screwdriver into the gap between the links to push on as a lever and force them apart.

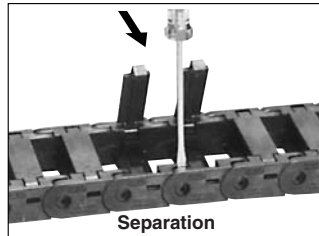
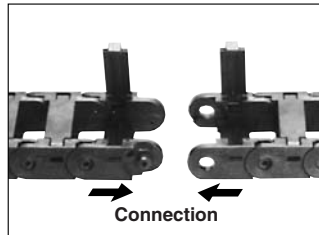

● Opening and closing the PO series (fully covered type) flap (lid)

In the connected condition, the flaps for each link are in an overlay configuration. When opening or closing the flaps of the connected links, bend the links connection until the bending radius is as small as possible.

To open the flap, insert a flat blade screwdriver into the rectangular hole on either side of the link, and push up the flap hook by trying the principle of the lever. To close, use fingers to push the flap down, taking care that the flaps overlay.

Connection

First, open up the flaps on the two links to be connected, then align the links and push them together from both sides.

Separation

First, open up the flaps on the two links to be separated, then insert a flat blade screwdriver into the gap between the links to push on as a lever and force them apart.

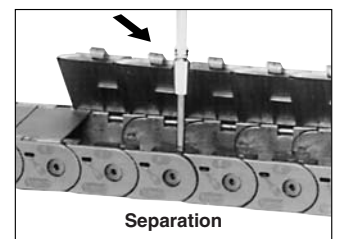
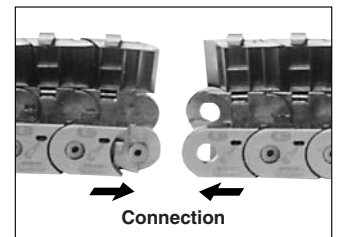
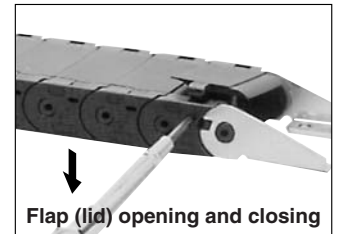

Operating Conditions

Ensure that the sum of the cross-section occupied by the cables and tubes to be placed into the plachain duct is 60% or less of the plachain duct cross-section.

Use at greater than 60% could result in cut cables (cabtyres, etc.) and broken tubes.

Selection Guideline

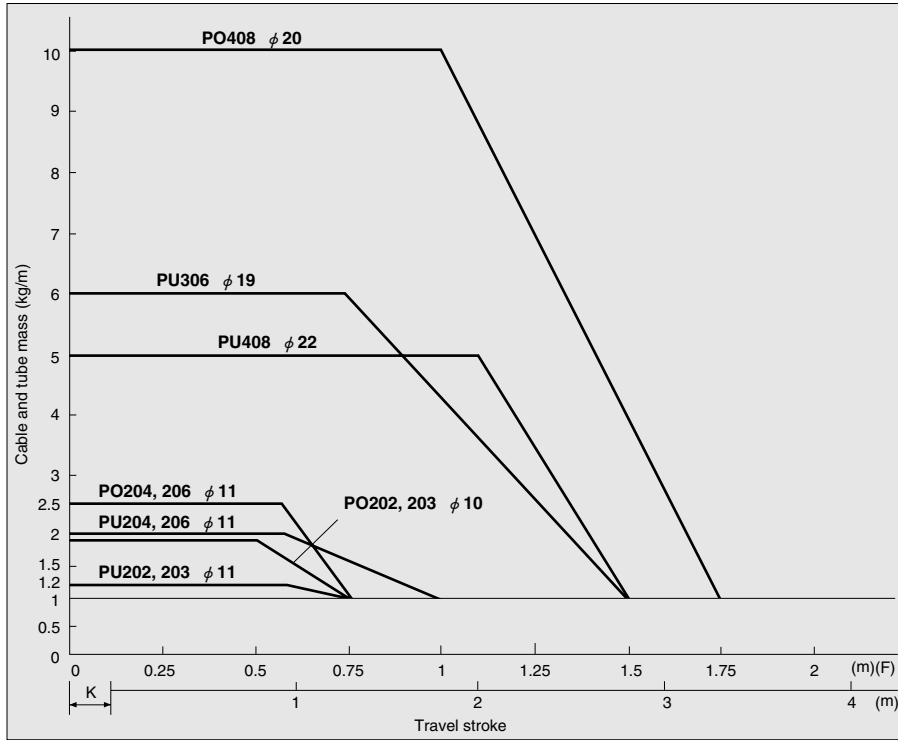

● Plachain duct performance graph

Based on the total mass, maximum outer diameter, and travel stroke of the cables and tubes used, select the optimum series model from the performance graph shown at left.

Ensure that the plachain duct bending radius is larger than the cable and tube bending radius.

- Notes :
1. F= Free span
The length capable of withstanding a load of 1kg/m [0.672lb./ft.].
 2. The K dimension includes a margin length.
 3. This graph assumes that the fixed end is located in the center of the travel stroke.

1kg/m = 0.672lb./ft.
1m = 3.28ft.

