



CAD drawing data catalog
is available.



KOGANEI

ACTUATORS GENERAL CATALOG

AIR HANDS SERIES CONTENTS

Features, Line-up	1381	Parallel Type Plain Bearing Specification	
Handling Instructions and Precautions	1384	Double Acting Type, Single Acting	
NHC1 Series		Normally Open Type Specifications	1430
Specifications	1399	Inner Construction, Order Codes	1431
Inner Construction, Order Codes	1400	Dimensions	1432
Dimensions	1401	Swing Type	
NHB Series		Double Acting Type, Single Acting	
Parallel Type Linear Guide Specification		Normally Open Type Specifications	1434
Double Acting Type, Single Acting		Inner Construction, Order Codes	1435
Normally Open Type Specifications	1403	Dimensions	1436
Inner Construction, Order Codes	1404	Swing Type High Precision,	
Dimensions	1405	180° Open Specification	
Parallel Type Linear Guide Specification		Double Acting Type Specifications	1439
Long Stroke		Inner Construction, Order Codes	1440
Double Acting Type Specifications	1407	Dimensions	1441
Inner Construction, Order Codes	1408	Swing Type 180° Open Specification	
Dimensions	1409	Double Acting Type Specifications,	
Parallel Type Linear Guide Specification		Inner Construction	1443
with Fingers		Order Codes, Dimensions	1444
Double Acting Type, Single Acting		WHDP Series	
Normally Open Type Specifications	1411	Rack Operation Parallel Type	
Inner Construction, Order Codes	1412	Wide Type Air Hands,	
Dimensions	1413	Double Acting Type Specifications,	
Parallel Type Linear Guide Specification		Order Codes	1445
with Rubber Cover		Inner Construction	1446
Double Acting Type, Single Acting		Dimensions	1447
Normally Open Type Specifications	1415	NHB Series	
Inner Construction, Order Codes	1416	Parallel Type Mechanical Hands	
Dimensions	1417	Linear Guide Specification	
Parallel Type Linear Guide Specification		Mechanical Hands Specifications	1449
for Clean Systems		Inner Construction, Order Codes	1450
Double Acting Type Specifications	1419	Dimensions	1451
Inner Construction, Order Codes	1420	Three-finger Type Linear Guide Specification	
Dimensions	1421	Mechanical Hands Specifications,	
Three-finger Type Linear Guide Specification		Inner Construction, Order Codes	1455
Specifications,		Dimensions	1456
Inner Construction, Order Codes	1423	Sensor Switches	1458
Dimensions	1424		
Parallel Type Cross Roller Bearing Specification			
Double Acting Type, Single Acting			
Normally Open Type Specifications	1426		
Inner Construction, Order Codes	1427		
Dimensions	1428		



Caution Before use, be sure to read the "Safety Precautions" on p. 57.

AIR HANDS SERIES

Full Line-up



Page 1399

Parallel Type Linear Guide Specification NHC1 Series

- **40% lighter:** Now about 40% lighter than the previous NHB series linear guide specification.
- **45% more compact:** Reduced the width, length, and height.
- **Strong:** Use of high-rigidity linear guide achieves repeatability of $\pm 0.01\text{mm}$ [$\pm 0.0004\text{in.}$] or less. Centering accuracy is also $\pm 0.07\text{mm}$ [$\pm 0.0028\text{in.}$] or less.



Page 1403

Parallel Type Linear Guide Specification

- Lever portion uses a linear guide for long operating life, high precision, long lever travel gripping, and overhang gripping.
- Gripping position repeatability $\pm 0.01\text{mm}$ [$\pm 0.0004\text{in.}$]. Centering accuracy is also $\pm 0.07\text{mm}$ [$\pm 0.0028\text{in.}$].
- Magnet for sensor switch is standard equipment.



Page 1407

Parallel Type Linear Guide Specification Long Stroke

- Open/closed stroke is about double the previous model.
- Gripping position repeatability is $\pm 0.01\text{mm}$ [$\pm 0.0004\text{in.}$].



Page 1411

Parallel Type Linear Guide Specification with Fingers

- Fingers attachment is simple to install.
- Gripping position repeatability is $\pm 0.01\text{mm}$ [$\pm 0.0004\text{in.}$].

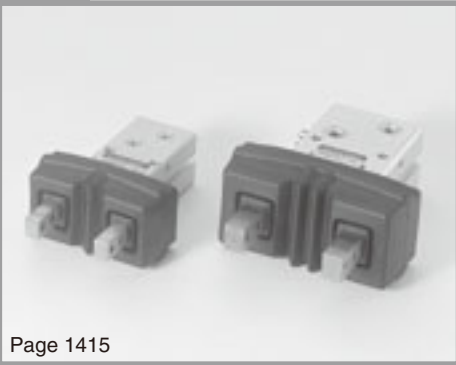

Page 1415

Parallel Type Linear Guide Specification with Rubber Cover

- Dust protection cover is standard equipment.
- Lever portion uses a linear guide for long operating life, high precision, long lever travel gripping, and overhang gripping.
- Gripping position repeatability $\pm 0.01\text{mm}$ [$\pm 0.0004\text{in.}$].
- Magnet for sensor switch is standard equipment.



Page 1419

Parallel Type Linear Guide Specification for Clean Systems

- Clean rating corresponds to Class 4 (during suction).
- Gripping position repeatability is $\pm 0.01\text{mm}$ [$\pm 0.0004\text{in.}$].

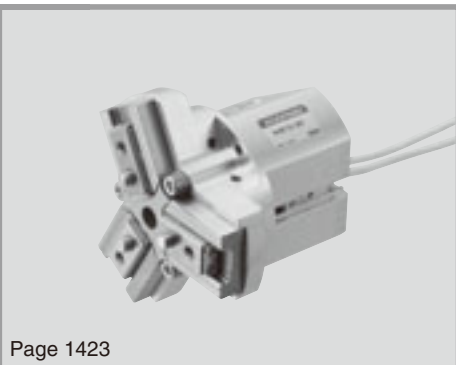

Page 1423

Three-finger Type Linear Guide Specification

- Linear guides are used on three-finger hand! Superior load and moment resistance.
Centering accuracy is $\pm 0.05\text{mm}$ [$\pm 0.0020\text{in.}$] or less.
Gripping position repeatability is $\pm 0.01\text{mm}$ [$\pm 0.0004\text{in.}$] or less.
- Body is equipped with a hollow space. Convenient for installing a cylinder for workpiece release, etc.



Page 1426

Parallel Type Cross Roller Bearing Specification

- Lever portion uses cross roller bearings for long operating life and high precision.
- Gripping position repeatability $\pm 0.01\text{mm}$ [$\pm 0.0004\text{in.}$].
- Dust protection cover is optional.
- Magnet for sensor switch is standard equipment.



Page 1430

Parallel Type Plain Bearing Specification

- Lever portion uses a slide plate for long operating life.
- Magnet for sensor switch is standard equipment.
- 3-way direct mounting.



Page 1434

Swing Type

- Lever uses chrome molybdenum steel, with quench hardened major parts, to achieve long operating life.
- Magnet for sensor switch is standard equipment.
- 3-way direct mounting.

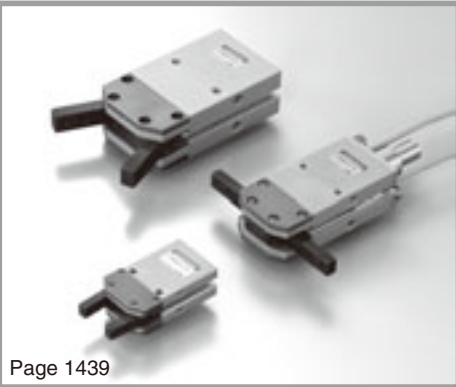

Page 1439

Swing Type High Precision, 180° Open Specification

- Uses a thrust bearing in the lever support area to achieve high precision, high rigidity, and long operating life.
- Uses a link mechanism for compact, high gripping force. Open-close up to 180°.



Page 1443

Swing Type 180° Open Specification

- Lever uses chrome molybdenum steel, with quench hardened major parts, to achieve long operating life.
- Open/close angle 180°, to allow gripping and releasing of workpieces without retracting a hand body.
- Magnet for sensor switch is standard equipment.
- 3-way direct mounting.

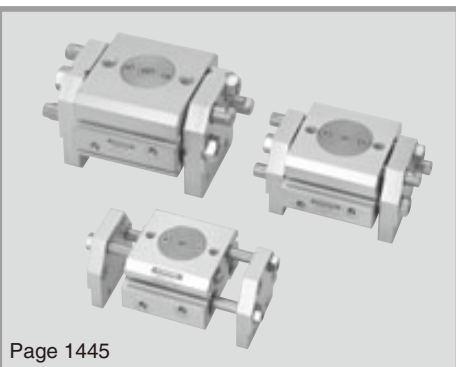

Page 1445

Rack Operation Parallel Type

- Four types of lever with open/close travel strokes, at 24, 32, 40, and 50mm [0.945, 1.260, 1.575, 1.969in.].
- Magnet for sensor switch is standard equipment.

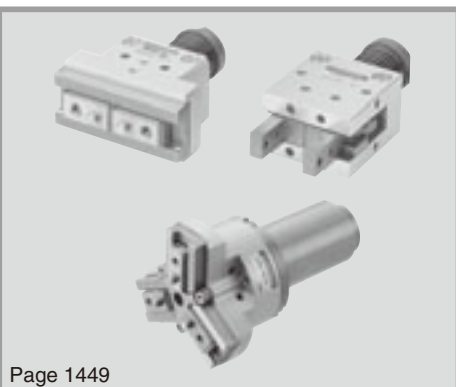

Page 1449

Mechanical Hands

- Because these do not require air piping, these are optimum for locations where air piping cannot reach (such as on index table, etc.).
- Three types available, including parallel type, parallel type linear guide specification, and linear guide specification three-finger type.
- Spring force can be set to strong or weak in response to the workpiece.
- The linear guide specification uses a linear guide on the lever, to achieve high precision ($\pm 0.01\text{mm}$ [$\pm 0.0004\text{in.}$]) and long operating life.

Handling Instructions and Precautions



General precautions

Media

1. Use air for the media. For the use of any other media, consult us.
2. Air used for the air hand (gripper) should be clean air that contains no deteriorated compressor oil, etc. Install an air filter (with filtration of a minimum 40µm) near the air hand (gripper) or valve to remove collected liquid or dust. In addition, drain the air filter periodically.

Piping

1. Always thoroughly blow off (use compressed air) the tubing before connecting it to the air hand (gripper). Entering metal chips, sealing tape, rust, etc., generated during piping work could result in air leaks or other defective operation.
2. When screwing in piping or fittings to the air hand (gripper), tighten to the appropriate tightening torque shown below.

Connecting thread	Tightening torque N · m [ft · lbf]
M3×0.5	0.6 [0.44]
M5×0.8	1.6 [1.18]

Lubrication

Cylinder portion

The product can be used without lubrication, if lubrication is required, use Turbine Oil Class 1 (ISO VG32) or equivalent. Avoid using spindle oil or machine oil.

Lever slide portion

The product can be used without lubrication, if lithium-based grease or urea-based grease is applied, it will increase the product's operating life.

Atmosphere

If using in locations subject to dripping water, dripping oil, etc., or to large amount of dust, use a cover to protect the unit. Select the rubber cover specification, if using in locations subject to large amounts of dust.



Selection

Effective gripping force

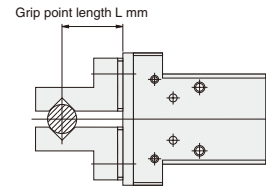

● Parallel type Linear guide specification (NHC1 series)

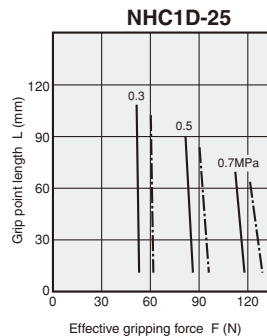
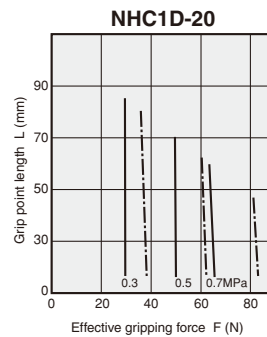
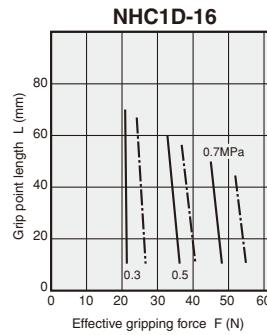
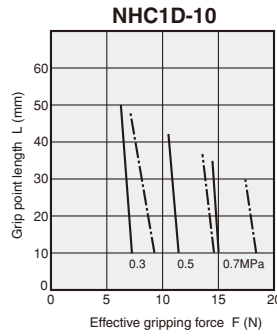

1mm = 0.0394in.
1N = 0.2248lbf.
1MPa = 145psi.

Handling Instructions and Precautions



Selection

Effective gripping force

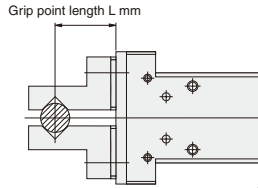

--- : Open side
— : Closed side

● Parallel type Linear guide specification (with rubber cover)

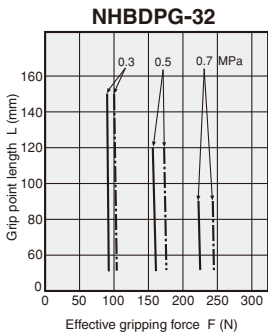
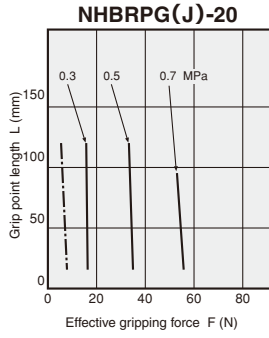
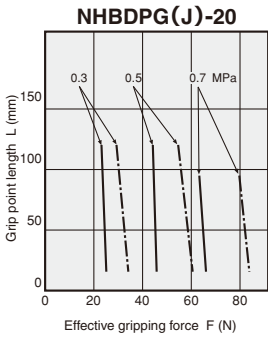
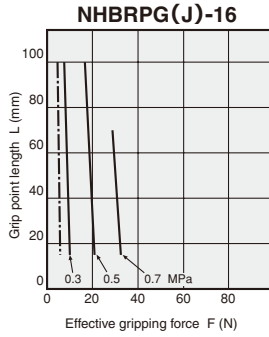
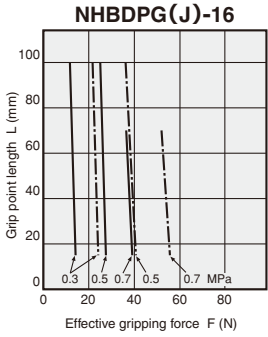
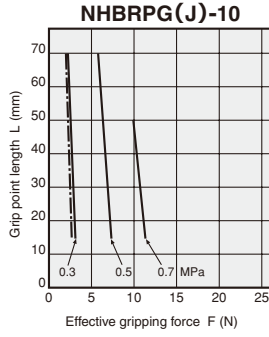
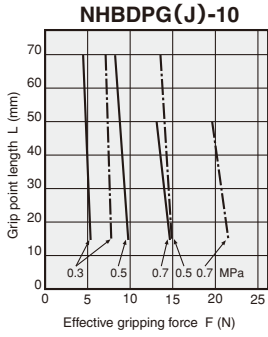
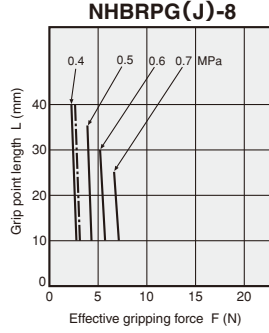
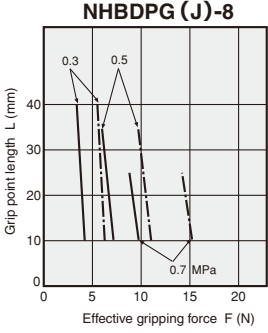

1mm = 0.0394in.
1N = 0.2248lbf.
1MPa = 145psi.

● Linear guide specification Long stroke

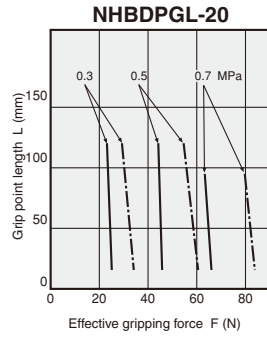
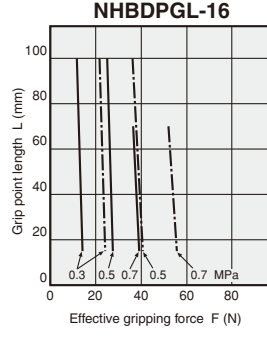
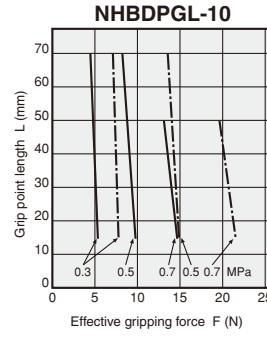
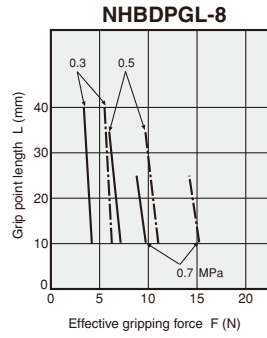

1mm = 0.0394in.
1N = 0.2248lbf.
1MPa = 145psi.

● Linear guide specification for clean systems

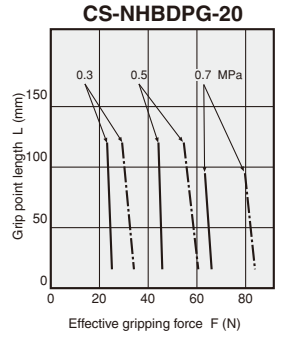
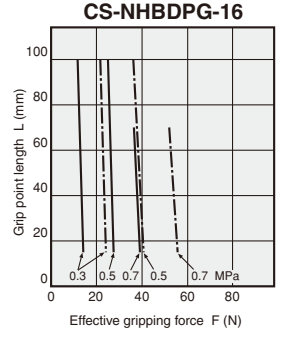
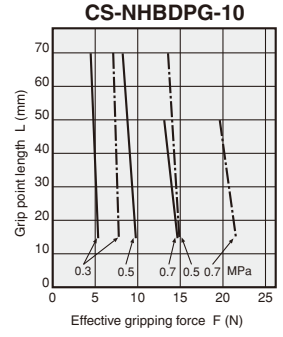
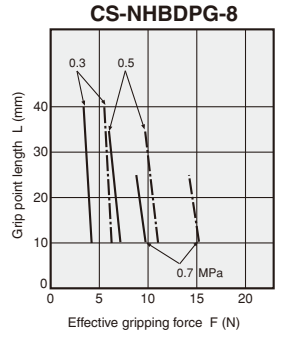

1mm = 0.0394in.
1N = 0.2248lbf.
1MPa = 145psi.

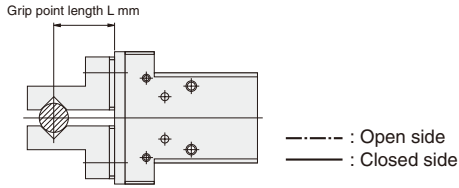

● Linear guide specification With fingers

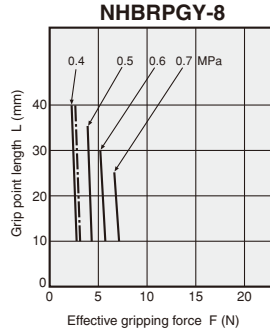
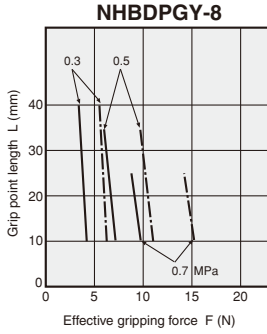

● Three-finger type Linear guide specification Air hands
(Lever open side and closed side are same value.)

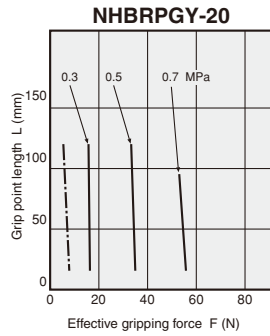
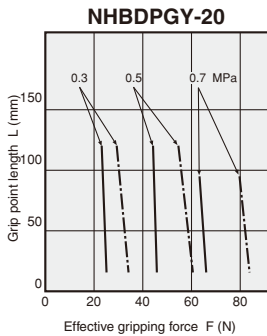
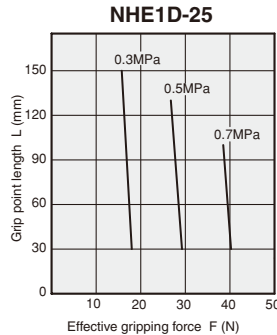
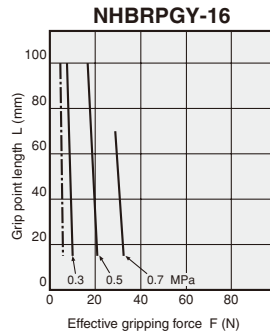
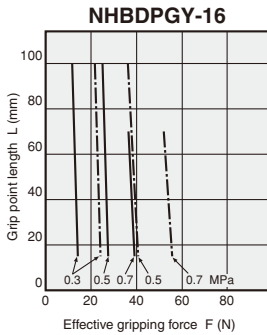
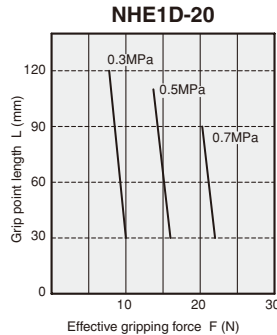
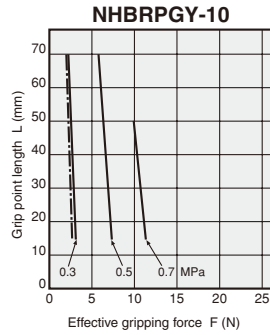
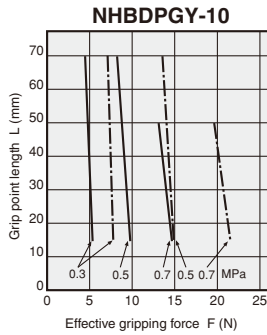
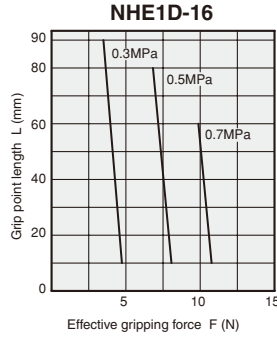

1mm = 0.0394in.
1N = 0.2248lbf.
1MPa = 145psi.

1mm = 0.0394in.
1N = 0.2248lbf.
1MPa = 145psi.

Handling Instructions and Precautions

Effective gripping force

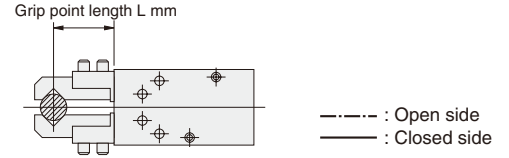
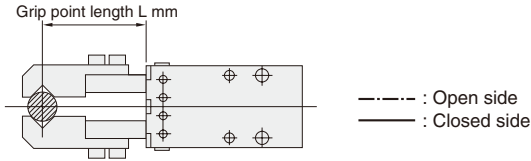

● Parallel type Cross roller bearing specification

NHBDPA-6

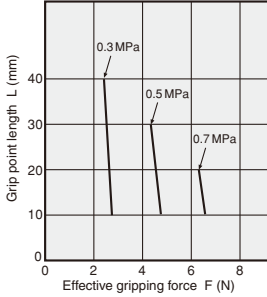

NHBRPA-6

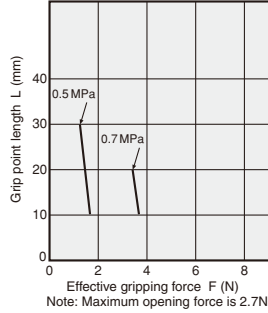

Note: Opening force is equal to or greater than closing force.

NHBDPA-10

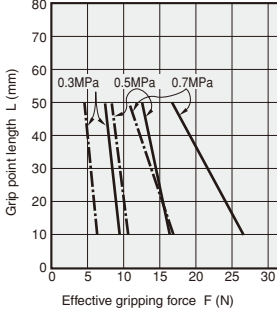

NHBRPA-10

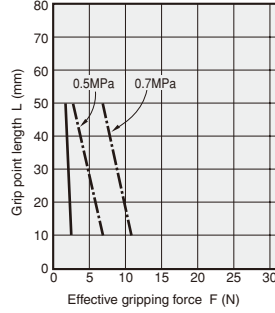

NHBDPA-16

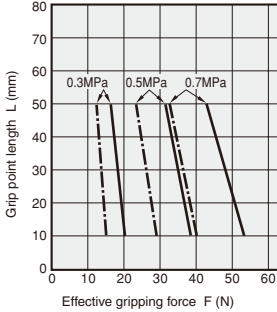

NHBRPA-16

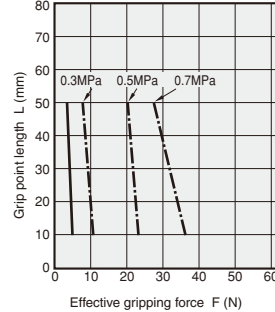

NHBDPA-20

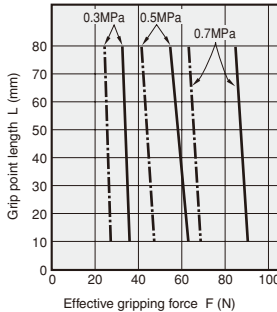

NHBRPA-20

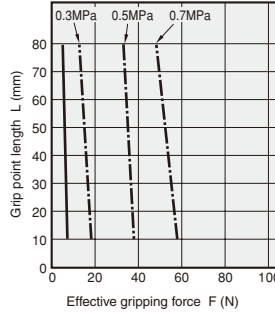

NHBDPA-25

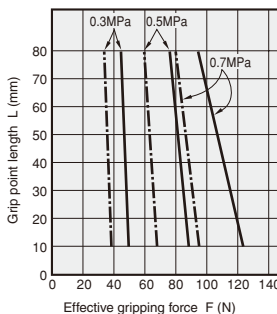

NHBRPA-25

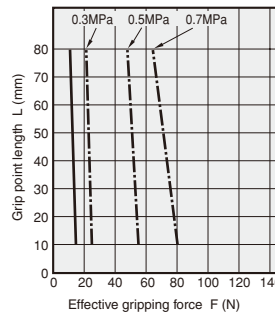

● Parallel type Plain bearing specification

NHBDP-10

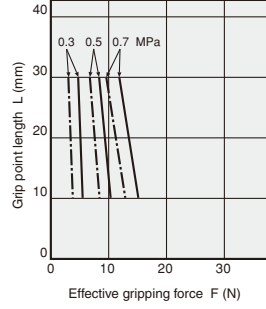

NHBRP-10

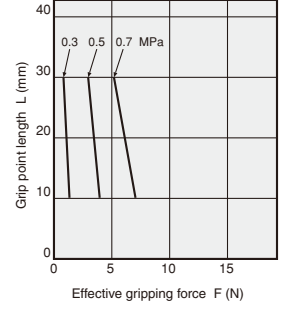

NHBDP-16

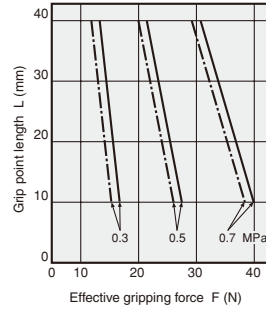

NHBRP-16

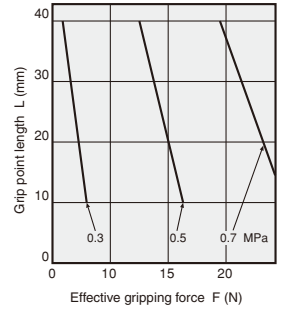

NHBDP-20

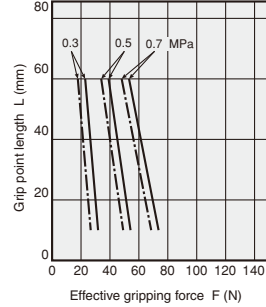

NHBRP-20

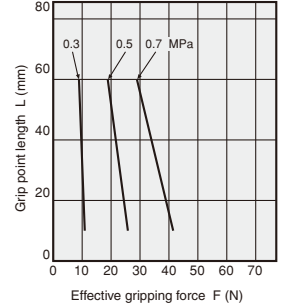

NHBDP-25

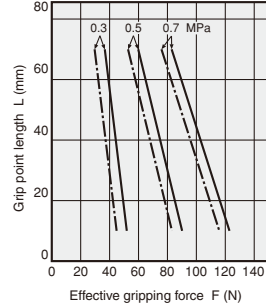

NHBRP-25

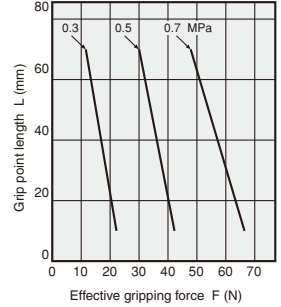

1mm = 0.0394in.
1N = 0.2248lbf.
1MPa = 145psi.

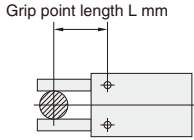

--- : Open side
 — : Closed side

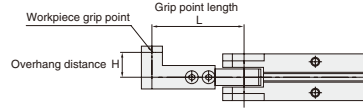

● **Swing type**

● **Swing type**
 High precision, 180° open specification

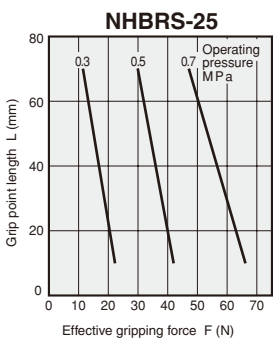
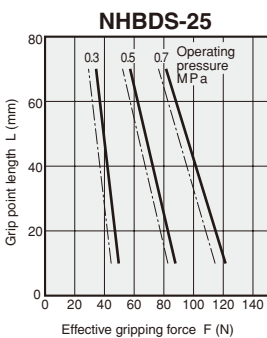
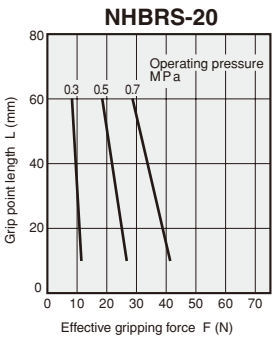
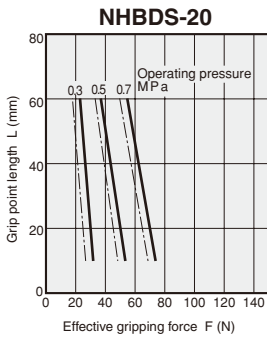
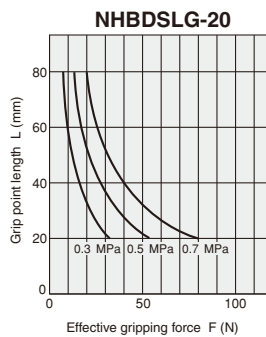
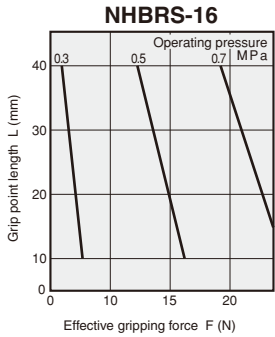
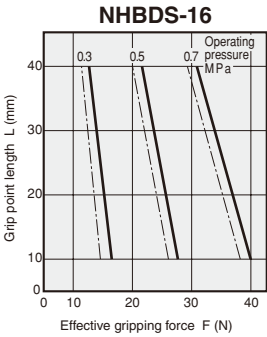
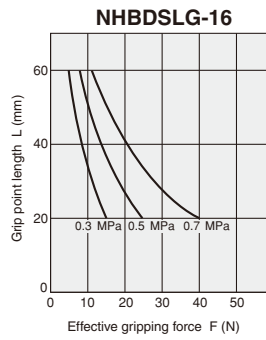
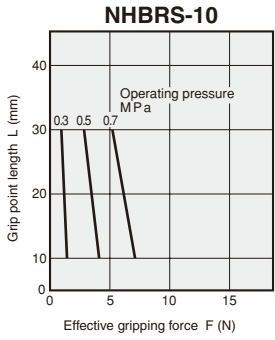
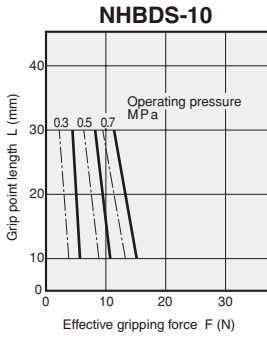
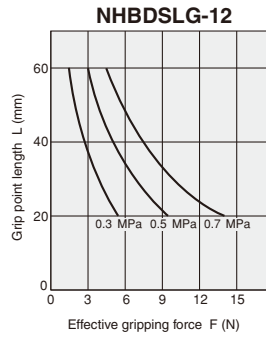
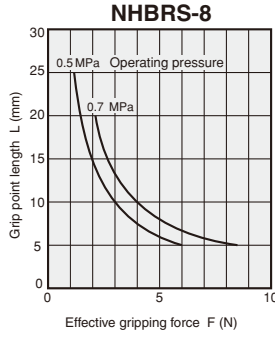
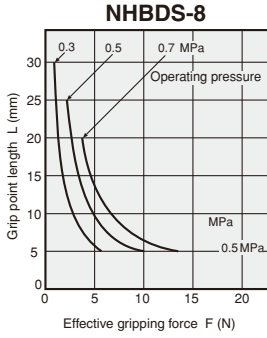

Note: Graphs show the force of closing direction.

1mm = 0.0394in.
 1N = 0.2248lb.
 1MPa = 145psi.

Handling Instructions and Precautions

Effective gripping force

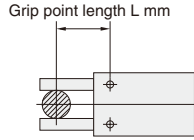

--- : Open side
 — : Closed side

Caution: For the grip point length specifications, see p.1387 for parallel type plain bearing specification and p.1385 for parallel type linear guide specification.

● Swing type 180° open specification

NHBDSL-12

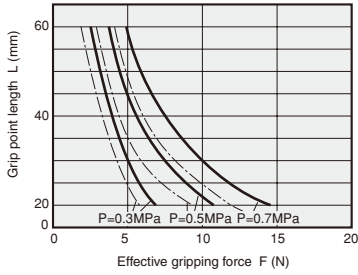

NHBDSL-16

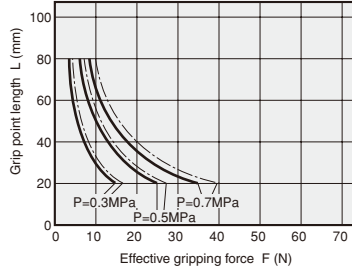

NHBDSL-20

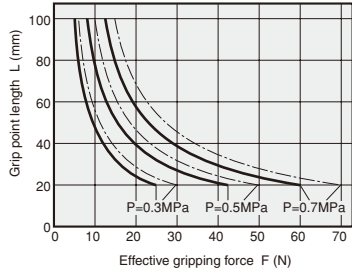

NHBDSL-25

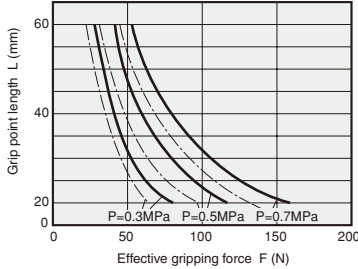

1mm = 0.0394in.
 1N = 0.2248lbf.
 1MPa = 145psi.

● Parallel type Mechanical hands

NHBMRP-10·NHBMP-10

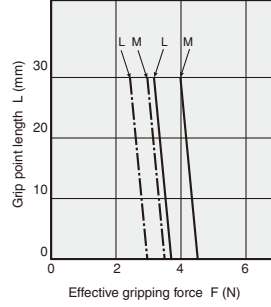

NHBMRP16·NHBMP16

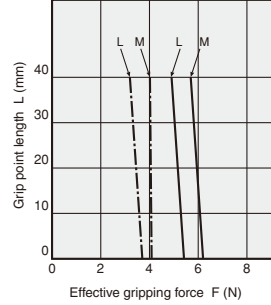

NHBMRP-20·NHBMP-20

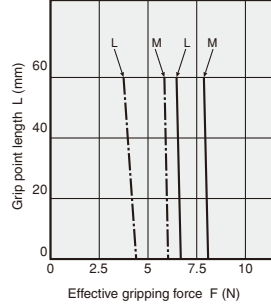

1mm = 0.0394in.
 1N = 0.2248lbf.

● Parallel type Linear guide specification Mechanical hands

NHBMPG-8

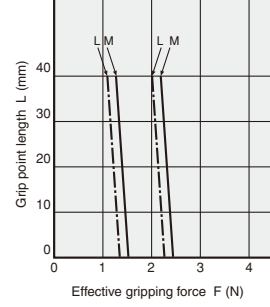

NHBMPG-10

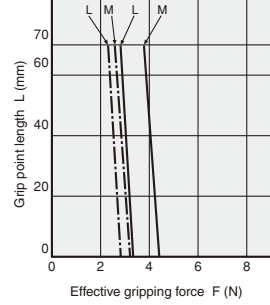

NHBMPG-16

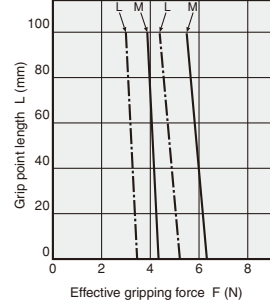

NHBMPG-20

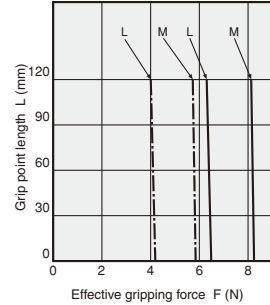

1mm = 0.0394in.
 1N = 0.2248lbf.

● Three-finger type Linear guide specification Mechanical hands

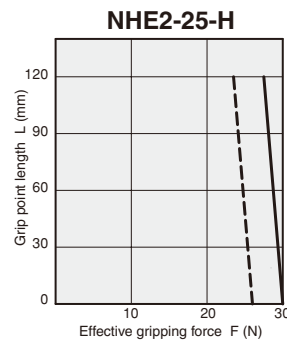
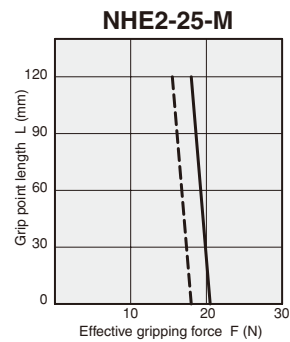
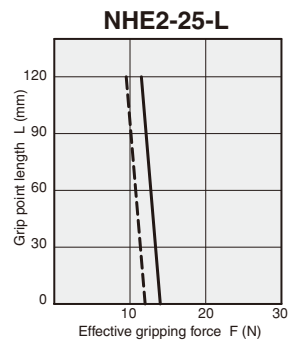
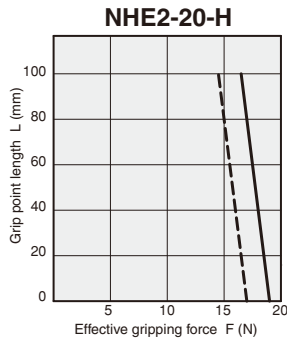
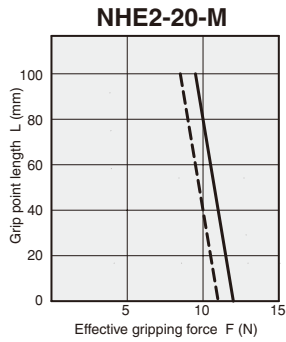
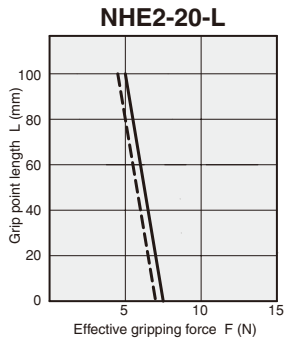
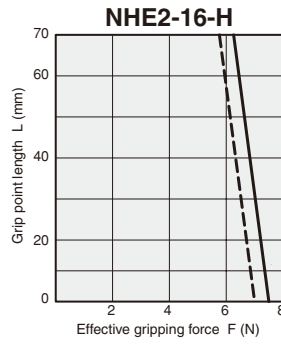
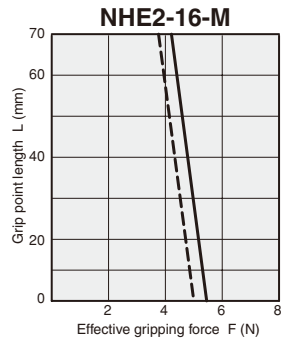
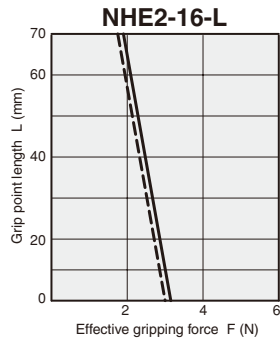

— When lever fully open
 - - - When lever fully closed

1mm = 0.0394in.
 1N = 0.2248lbf.

Handling Instructions and Precautions

Effective gripping force

● WHDP series Rack operation parallel type

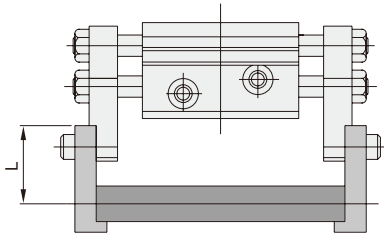

L=Grip point length

Note: Gripping force is the same for both the open and closed sides.

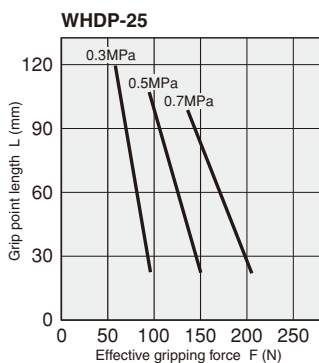
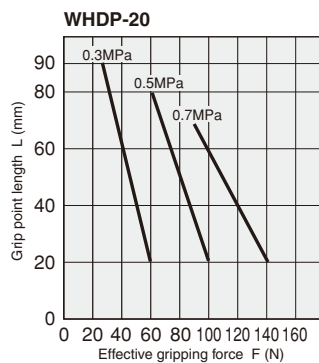
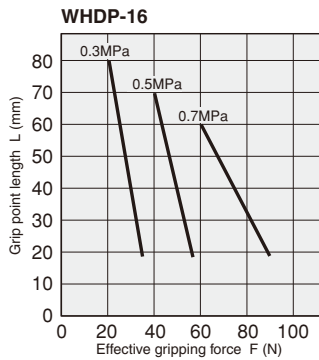
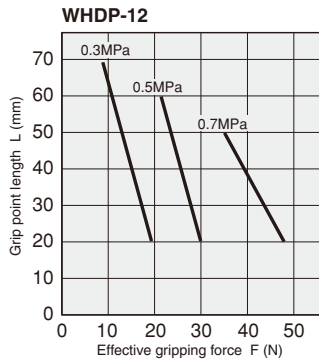

Grip point limit range

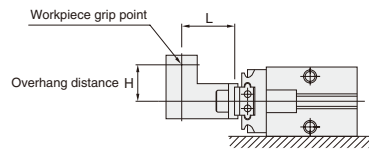

● Parallel type Linear guide specification (NHC1 series)

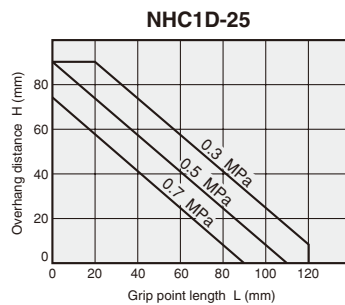
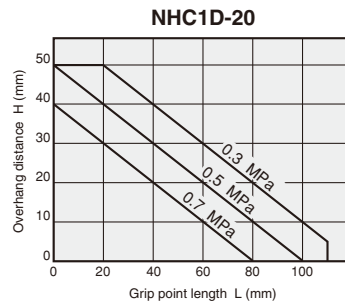
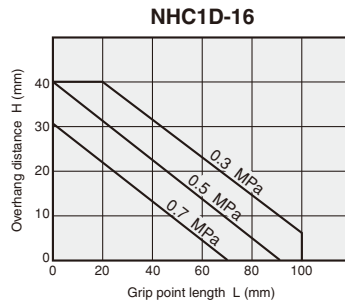
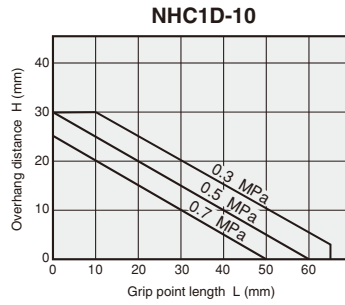

● Swing type High precision, 180° open specification

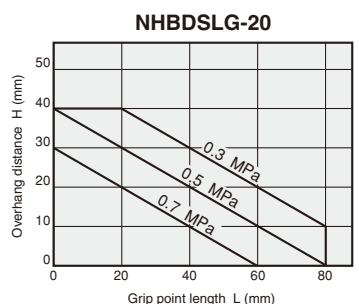
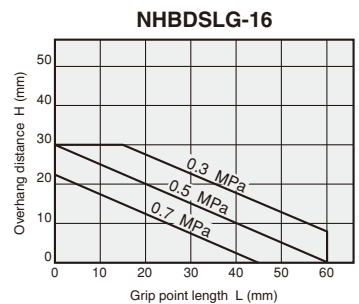
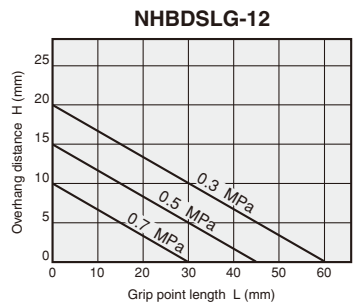

1mm = 0.0394in.
1MPa = 145psi.

1mm = 0.0394in.
1N = 0.2248lbf.
1MPa = 145psi.

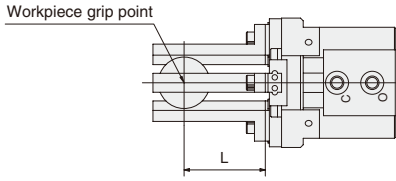

● **Three-finger type Linear guide specification Air hands**

NHE1D-16

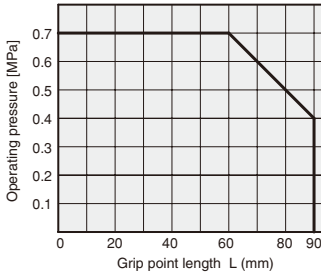

NHE1D-20

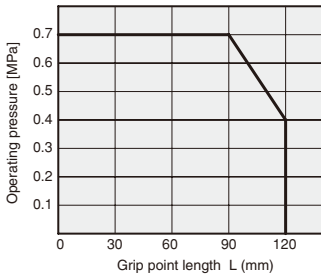

NHE1D-25

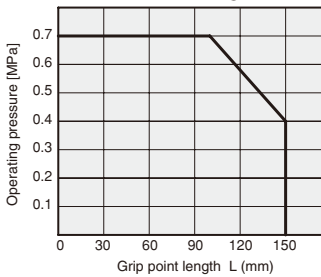

1mm = 0.0394in.
1MPa = 145psi.

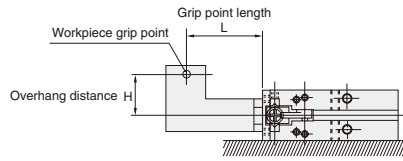

● **Parallel type Cross roller bearing specification**

**NHBDPA-6
NHBRPA-6**

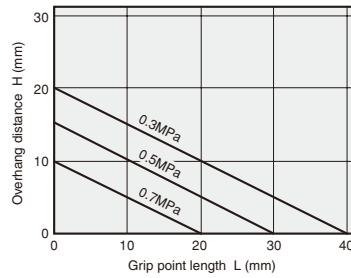

**NHBDPA-10
NHBRPA-10**

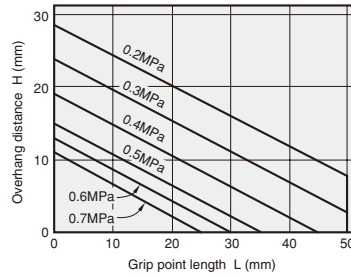

**NHBDPA-16
NHBRPA-16**

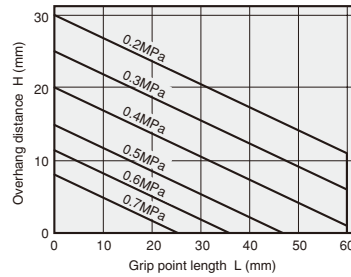

**NHBDPA-20
NHBRPA-20**

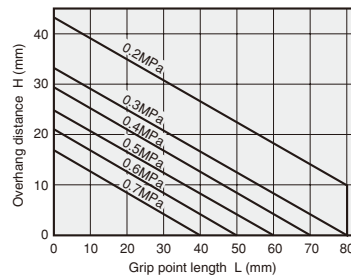

**NHBDPA-25
NHBRPA-25**

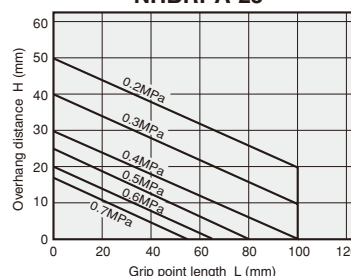

1mm = 0.0394in. 1MPa = 145psi.

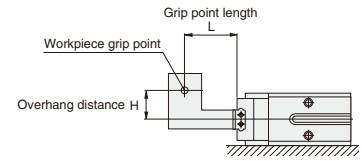

● **Parallel type Linear guide specification (with rubber cover)**

**NHBDPG(J)-8
NHBRPG(J)-8**

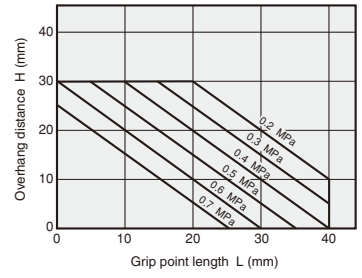

**NHBDPG(J)-10
NHBRPG(J)-10**

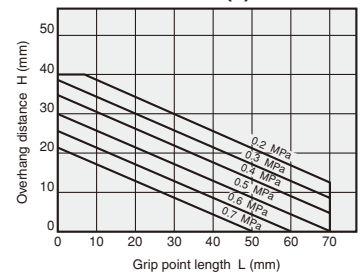

**NHBDPG(J)-16
NHBRPG(J)-16**

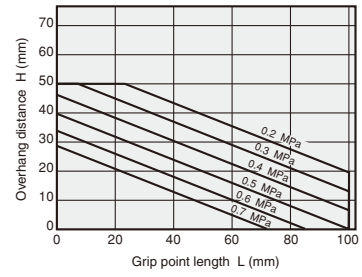

**NHBDPG(J)-20
NHBRPG(J)-20**

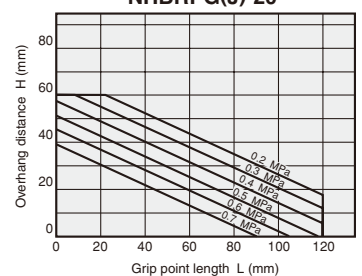

NHBDPG-32

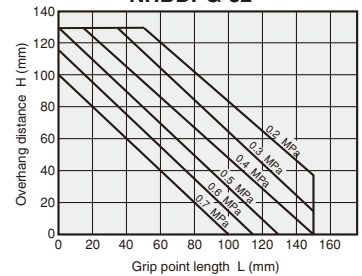

1mm = 0.0394in. 1MPa = 145psi.

Handling Instructions and Precautions

Grip point limit range

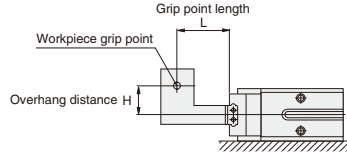

● Linear guide specification Long stroke

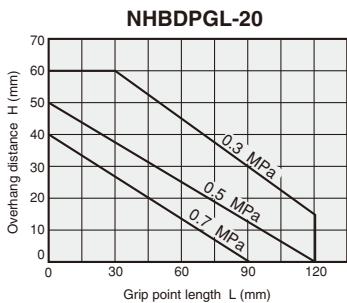
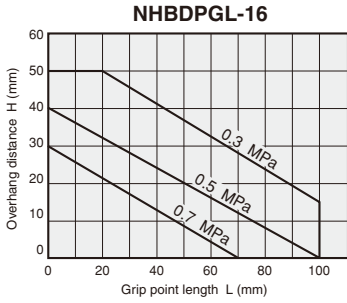
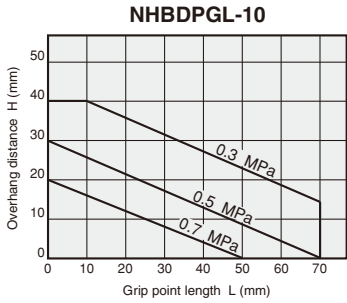
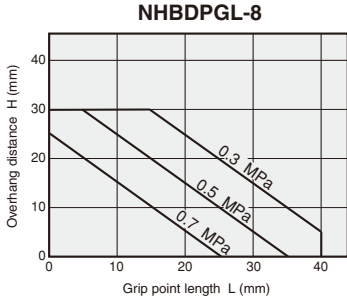

1mm = 0.0394in.
1MPa = 145psi.

● Linear guide specification With fingers

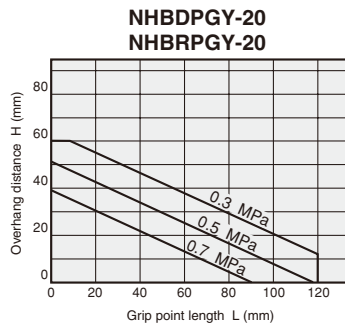
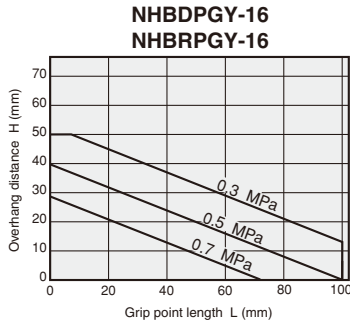
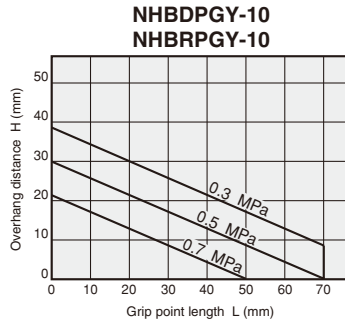
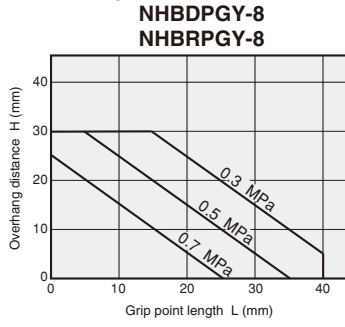

1mm = 0.0394in.
1MPa = 145psi.

● Linear guide specification for clean systems

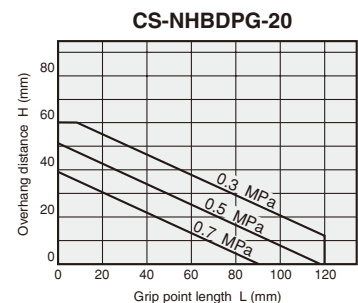
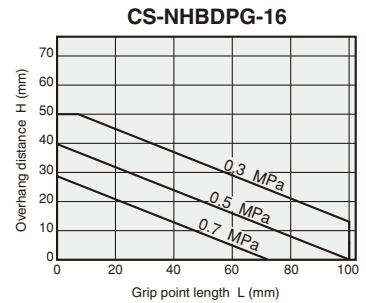
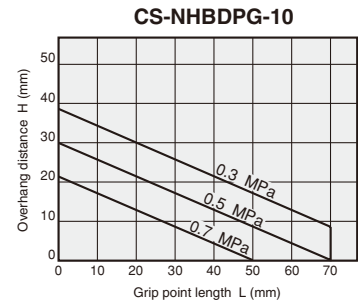
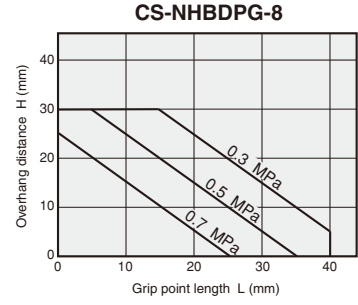

1mm = 0.0394in.
1MPa = 145psi.

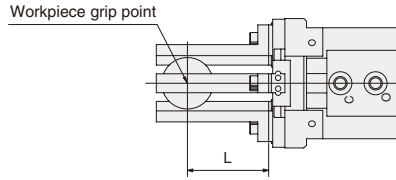

● **Parallel type**
Linear guide specification
Mechanical hands

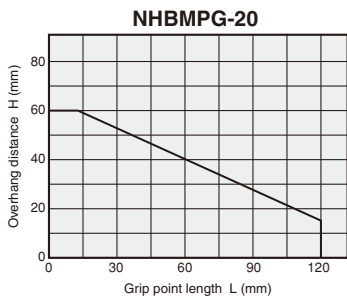
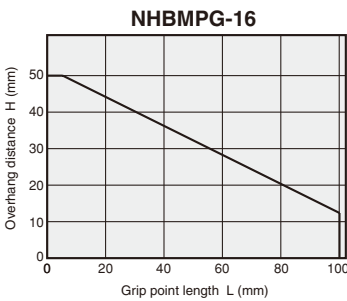
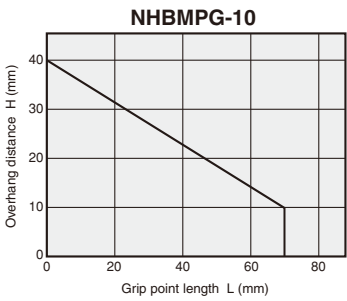
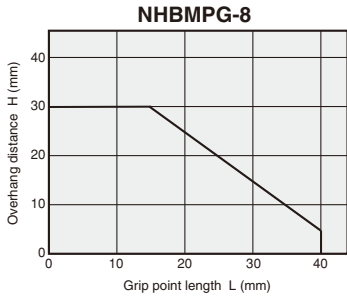

1mm = 0.0394in.

● **Three-finger type**
Linear guide specification
Mechanical hands

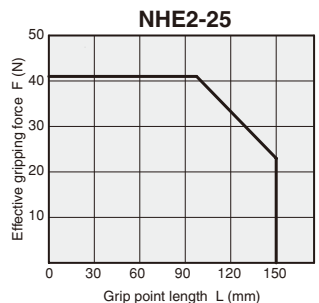
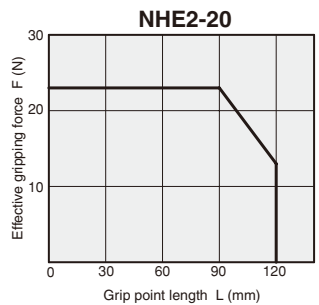
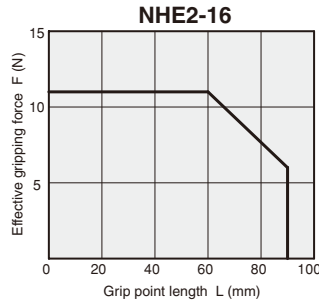

1N = 0.2248lbf.
 1mm = 0.0394in.

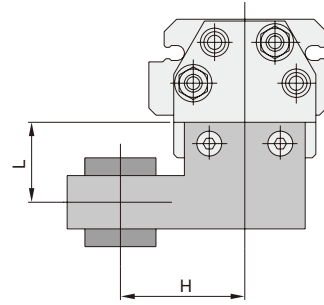

H = Overhang distance
 L = Grip point length

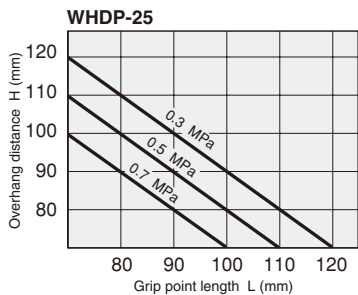
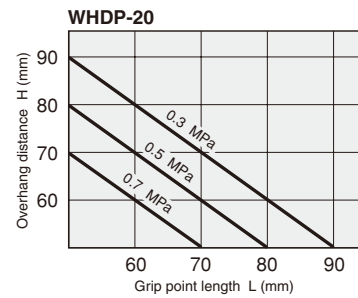
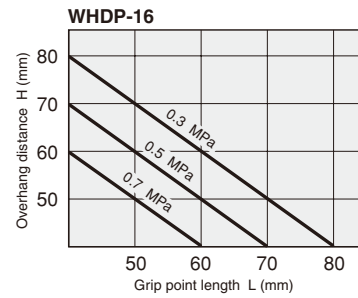
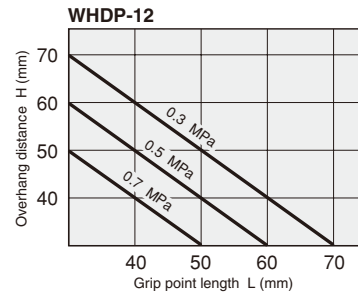

1mm = 0.0394in. 1MPa = 145psi.

Handling Instructions and Precautions

Allowable load and allowable moment

● Linear guide specification

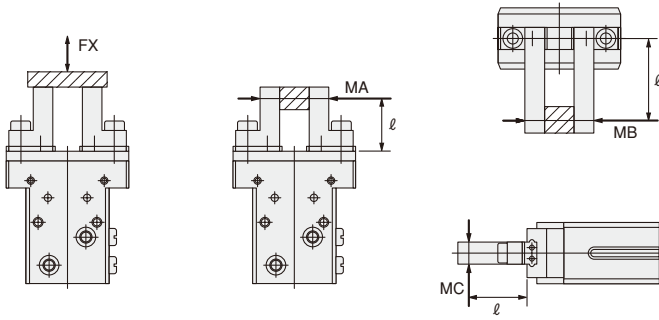

● NHB series

Model	Load and moment			
	FX N [lbf.]	MA N·m [in·lbf]	MB N·m [in·lbf]	MC N·m [in·lbf]
(CS-)NHB□P□□-8	12 [2.7]	0.04 [0.4]	0.04 [0.4]	0.08 [0.7]
(CS-)NHB□P□□-10	49 [11.0]	0.39 [3.5]	0.39 [3.5]	0.78 [6.9]
(CS-)NHB□P□□-16	117 [26.3]	0.98 [8.7]	0.98 [8.7]	1.96 [17.3]
(CS-)NHB□P□□-20	196 [44.1]	1.47 [13.0]	1.47 [13.0]	2.94 [26.0]
NHBDPG-32	350 [78.7]	3 [26.6]	3 [26.6]	6 [53.1]

Remark: l is the distance from the main body end to the gripping point.

● NHC1 series

Model	Load and moment			
	FX N [lbf.]	MA N·m [in·lbf]	MB N·m [in·lbf]	MC N·m [in·lbf]
NHC1D-10	60 [13.5]	0.3 [2.7]	0.3 [2.7]	0.6 [5.3]
NHC1D-16	100 [22.5]	0.8 [7.1]	0.8 [7.1]	1.6 [14.2]
NHC1D-20	160 [36.0]	1.4 [12.4]	1.4 [12.4]	2.8 [24.8]
NHC1D-25	280 [62.9]	2.4 [21.2]	2.4 [21.2]	4.8 [42.5]

Remark: l is the distance from the main body end to the gripping point.

● Three-finger type linear guide specification

Model	Load and moment			
	FX N [lbf.]	MA N·m [in·lbf]	MB N·m [in·lbf]	MC N·m [in·lbf]
NHE1D-16	50 [11.2]	0.4 [3.5]	0.4 [3.5]	0.8 [7.1]
NHE1D-20	120 [27.0]	1 [8.9]	1 [8.9]	2 [17.7]
NHE1D-25	200 [45.0]	1.5 [13.3]	1.5 [13.3]	3 [26.6]

● WHDP series

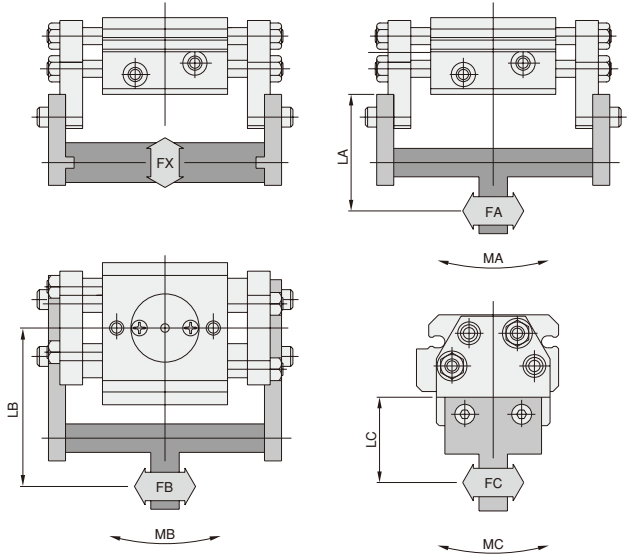

- $MA = FA \times LA$ (N·m)
- $MB = FB \times LB$ (N·m)
- $MC = FC \times LC$ (N·m)

Model	Load and moment			
	FX N [lbf.]	MA N·m [in·lbf]	MB N·m [in·lbf]	MC N·m [in·lbf]
WHDP-12	24 [5.4]	0.6 [5.3]	0.6 [5.3]	0.12 [1.06]
WHDP-16	36 [8.1]	1.1 [9.7]	1.1 [9.7]	0.22 [1.95]
WHDP-20	68 [15.3]	2.1 [18.6]	2.1 [18.6]	0.49 [4.34]
WHDP-25	93 [20.9]	2.7 [23.9]	2.7 [23.9]	0.76 [6.73]

Gripping

- When attaching fingers on the levers, design them as short and as light as possible. If the fingers are longer and heavier, the impact force when opening and closing will increase and cause a decrease in the gripping accuracy and/or wear and damage to the sliding portion. Also, to prevent the workpiece from falling down or being damaged, and to reduce the metal contact noise when gripping, plastic or rubber materials should be attached to the fingers at the part of contact.
In cases with long grip point length or high air pressure, there will be a large gripping moment exerted on the lever area that could result in damage to the lever. Always refer to the grip point limit range table, and use it within the allowed range.
- When the lever opening and closing time is faster than necessary in relation to the workpieces, the impact force increases when opening and/or closing and causes a decrease in the gripping accuracy, and wear and damage of the sliding portion etc., therefore a speed controller should be installed and the workpiece should be gripped to make the impact as small as possible.
- When moving the air gripper in straight lines or during circular operations, use a shock absorber etc., at the travel end to stop it as smoothly as possible. Sudden stops may cause the workpieces to pop out or fall from the gripper.
- When installing the fingers on the lever, use a wrench etc., to hold it so that the lever doesn't get twisted. Tighten the mounting bolts to the tightening torques shown in the table below.

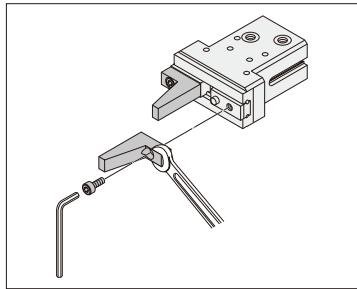

● NHC1 series

Model	Bolt	Maximum tightening torque N · m [in · lbf]
NHC1D-10	M3×0.5	0.6 [5.3]
NHC1D-16	M4×0.7	1.4 [12.4]
NHC1D-20	M5×0.8	2.9 [25.7]
NHC1D-25	M6×1.0	4.8 [42.5]

Caution: Avoid applications in which side loads are applied to the lever and lever mounting portion.

● NHB series (Linear guide specification)

Model	Bolt	Maximum tightening torque N · m [in · lbf]
(CS-)NHB□PG(L)-8	M2×0.4	0.15 [1.33]
(CS-)NHB□PG(L)-10	M3×0.5	0.6 [5.3]
(CS-)NHB□PG(L)-16	M4×0.7	1.4 [12.4]
(CS-)NHB□PG(L)-20	M5×0.8	2.9 [25.7]
NHBDPG-32	M6×1	4.8 [42.5]

Caution: Avoid applications in which side loads are applied to the lever and lever mounting portion.

● NHB series (High precision, 180° open specification)

Model	Bolt	Maximum tightening torque N · m [in · lbf]
NHBDSL-12	M3×0.5	0.6 [5.3]
NHBDSL-16	M3×0.5	0.6 [5.3]
NHBDSL-20	M4×0.7	1.4 [12.4]

Caution: Avoid applications in which side loads are applied to the lever and lever mounting portion.

● Three-finger type linear guide specification

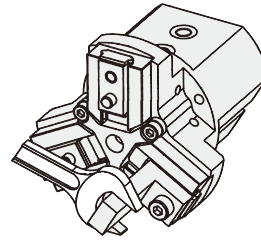

Model	Bolt	Maximum tightening torque N · m [in · lbf]
NHE1D/NHE2-16	M3×0.5	0.6 [5.3]
NHE1D/NHE2-20	M4×0.7	1.4 [12.4]
NHE1D/NHE2-25	M5×0.8	3.0 [26.6]

Caution: Avoid applications in which side loads are applied to the lever and lever mounting portion.

Workpiece

- NHB series (linear guide specification)
- Three-finger type (linear guide specification)

- Set the mass of the workpiece actually gripped to about 1/10~1/20 of the effective gripping force.
- Set the workpiece mass to about 1/30~1/50 of the effective gripping force when you move the air gripper while holding the workpiece.
- As the workpiece mass which can be gripped changes greatly depending on the material and shape of the fingers, the condition of the gripping surface and the moving speed of the workpiece, etc., the values in the specifications and graphs should be used for reference only.

Handling Instructions and Precautions

Body mounting method

● NHC1

1. Method for using body through holes. (Sensor switches cannot be mounted.)

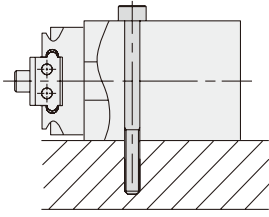

Model	Bolt	Maximum tightening torque N · m [in · lbf]
NHC1D-10	M3 × 0.5	0.6 [5.3]
NHC1D-16	M3 × 0.5	0.6 [5.3]
NHC1D-20	M4 × 0.7	1.4 [12.4]
NHC1D-25	M5 × 0.8	2.9 [25.7]

2. Method for using mounting threads on top or bottom of the body.

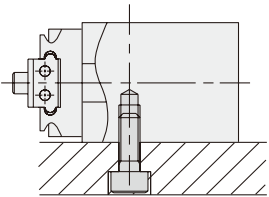

Model	Bolt	Maximum tightening torque N · m [in · lbf]
NHC1D-10	M4 × 0.7	1.4 [12.4]
NHC1D-16	M4 × 0.7	1.4 [12.4]
NHC1D-20	M5 × 0.8	2.9 [25.7]
NHC1D-25	M6 × 1.0	4.8 [42.5]

3. Method for using mounting threads on side surface of the body.

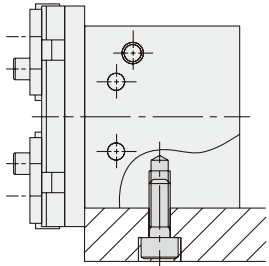

Model	Bolt	Maximum tightening torque N · m [in · lbf]
NHC1D-10	M3 × 0.5	0.6 [5.3]
NHC1D-16	M4 × 0.7	1.4 [12.4]
NHC1D-20	M5 × 0.8	2.9 [25.7]
NHC1D-25	M6 × 1.0	4.8 [42.5]

4. Method for using mounting threads on the head cover side of the body. (Some space is required in this case, however, because the sensor switch protrudes.)

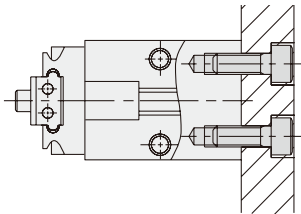

Model	Bolt	Maximum tightening torque N · m [in · lbf]
NHC1D-10	M3 × 0.5	0.6 [5.3]
NHC1D-16	M4 × 0.7	1.4 [12.4]
NHC1D-20	M5 × 0.8	2.9 [25.7]
NHC1D-25	M6 × 1.0	4.8 [42.5]

※ In examples 1, 2, and 4, locating holes can also be used. For the hole dimensions, see the Dimensions.

● NHB series (linear guide specification)

1. Method for using body through holes.

(On $\phi 8$ [0.315in.], $\phi 10$ [0.394in.], $\phi 16$ [0.630in.], $\phi 20$ [0.787in.], and $\phi 25$ [0.984in.] sensor switches cannot be mounted)

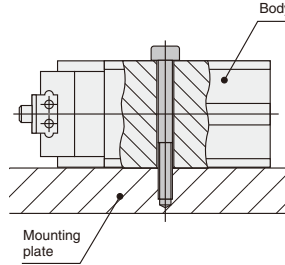

2. Method for using mounting threads on back surface of the body.

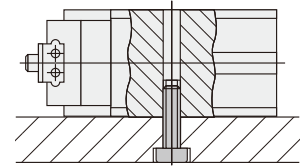

※ In examples 1 and 2, locating holes on the opposite side can also be used.

3. Method for using mounting threads on side surface of the body.

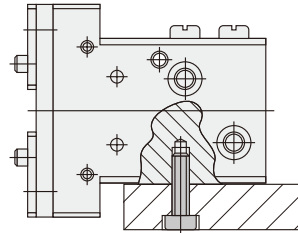

4. Method for using mounting threads on the head cover side of the body. (Some space is required in this case, however, because the sensor switch protrudes.)

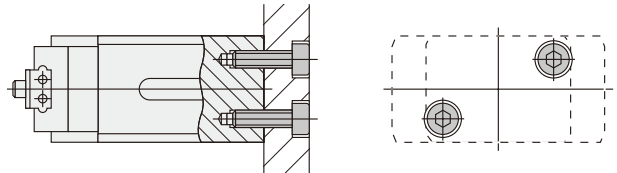

5. Method for using mounting threads on the lever side of the body. (Not available in $\phi 8$ [0.315in.] .)

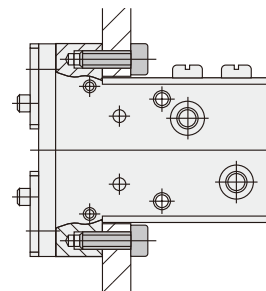

● **NHB series (High precision, 180° open specification)**

1. Method for using body through holes.
(Sensor switches cannot be mounted.)

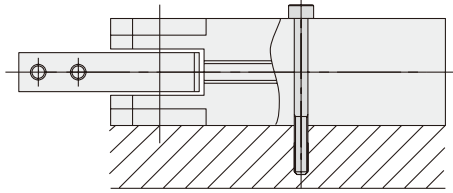

Model	Bolt	Maximum tightening torque N · m [in · lbf]
NHBDSLGL-12	M3×0.5	0.6 [5.3]
NHBDSLGL-16	M3×0.5	0.6 [5.3]
NHBDSLGL-20	M4×0.7	1.4 [12.4]

2. Method for using mounting threads on top or bottom of the body.

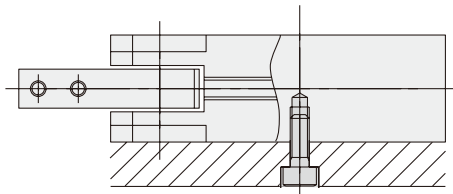

Model	Bolt	Maximum tightening torque N · m [in · lbf]
NHBDSLGL-12	M4×0.7	1.4 [12.4]
NHBDSLGL-16	M4×0.7	1.4 [12.4]
NHBDSLGL-20	M5×0.8	2.9 [25.7]

3. Method for using mounting threads on side surface of the body.

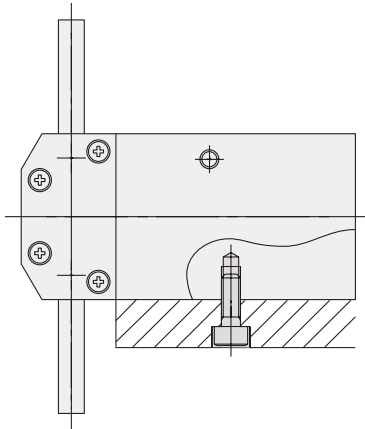

Model	Bolt	Maximum tightening torque N · m [in · lbf]
NHBDSLGL-12	M3×0.5	0.6 [5.3]
NHBDSLGL-16	M4×0.7	1.4 [12.4]
NHBDSLGL-20	M5×0.8	2.9 [25.7]

4. Method for using mounting threads on the head cover side of the body.

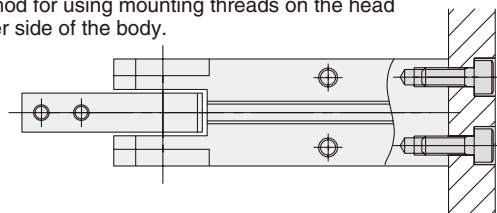

Model	Bolt	Maximum tightening torque N · m [in · lbf]
NHBDSLGL-12	M3×0.5	0.6 [5.3]
NHBDSLGL-16	M4×0.7	1.4 [12.4]
NHBDSLGL-20	M5×0.8	2.9 [25.7]

※ For Example 4, the locating hole can be used.
For the hole dimensions, see the Dimensions on p.1441-1442.

● **Three-finger type linear guide specification (Air hand NHE1D)**

1. Method for using body through holes.

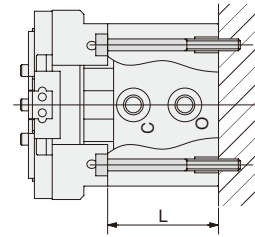

Bore mm	Bolt	Maximum tightening torque N · m [in · lbf]	L mm [in.]
16	M3×0.5	0.6 [5.3]	28 [1.102]
20	M3×0.5	0.6 [5.3]	34 [1.339]
25	M4×0.7	1.4 [12.4]	40 [1.575]

2. Method for using mounting threads on the back side of the through holes.

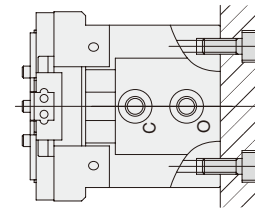

Bore mm	Bolt	Maximum tightening torque N · m [in · lbf]
16	M4×0.7	1.4 [12.4]
20	M4×0.7	1.4 [12.4]
25	M5×0.8	3.0 [26.6]

3. For locating hole dimensions (use for locating at time of mounting), see the page of dimensions.

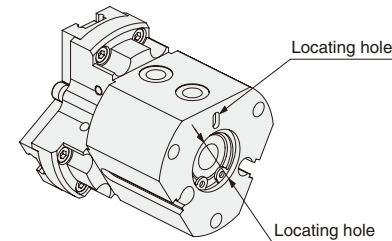

● **Three-finger type linear guide specification (Mechanical hand NHE2)**

1. Method for using body through holes.

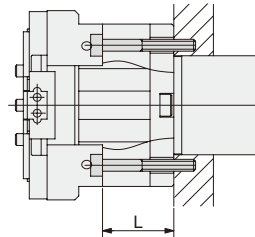

Nominal diameter mm	Bolt	Maximum tightening torque N · m [in · lbf]	L mm [in.]
16	M3×0.5	0.6 [5.3]	18 [0.709]
20	M3×0.5	0.6 [5.3]	21 [0.827]
25	M4×0.7	1.4 [12.4]	21 [0.827]

2. Method for using mounting threads on the back side of the through holes.

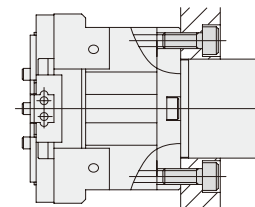

Nominal diameter mm	Bolt	Maximum tightening torque N · m [in · lbf]
16	M4×0.7	1.4 [12.4]
20	M4×0.7	1.4 [12.4]
25	M5×0.8	3.0 [26.6]

3. When using the shank portion.

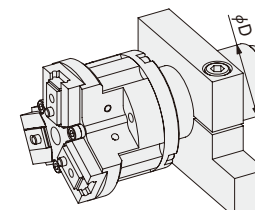

Nominal diameter mm	Shank diameter φ D
16	φ 25 ^{+0.01} _{-0.03} [0.9843 ^{-0.0004} _{-0.0012}]
20	φ 30 ^{+0.01} _{-0.03} [1.1811 ^{-0.0004} _{-0.0012}]
25	φ 30 ^{+0.01} _{-0.03} [1.1811 ^{-0.0004} _{-0.0012}]

NHC1 SERIES

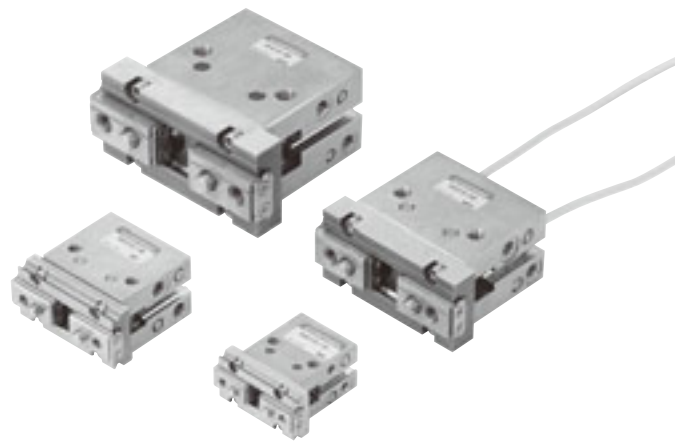

Symbols

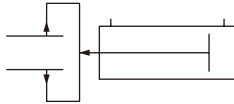

Specifications

Basic model		NHC1D-10	NHC1D-16	NHC1D-20	NHC1D-25
Cylinder bore size	mm [in.]	10 [0.394]	16 [0.630]	20 [0.787]	25 [0.984]
Operation type		Double acting type			
Media		Air			
Operating pressure range	MPa [psi.]	0.2~0.7 [29~102]	0.12~0.7 [17~102]	0.1~0.7 [15~102]	
Proof pressure	MPa [psi.]	1.05 [152]			
Operating temperature range	°C [°F]	0~60 [32~140]			
Maximum operating frequency	cycle/min	180			
Lubrication		Not required			
Effective gripping force (F) ^{Note 1}	Closed side	11 [2.5]	35 [7.9]	49 [11.0]	86 [19.3]
	Open side	17 [3.8]	46 [10.3]	65 [14.6]	111 [25.0]
Lever open/closed stroke	mm [in.]	4 [0.157]	6 [0.236]	10 [0.394]	14 [0.551]
Repeatability	mm [in.]	±0.01 [±0.0004]			
Port size		M3×0.5		M5×0.8	
Mass	g [oz.]	45 [1.59]	96 [3.39]	205 [7.23]	366 [12.91]

Note: 1. Values are obtained when gripping point length is 30mm [1.18in.] under operating pressure 0.5 MPa [73psi.]. For details of the effective gripping force, see the graphs on p.1384.

Inner Construction

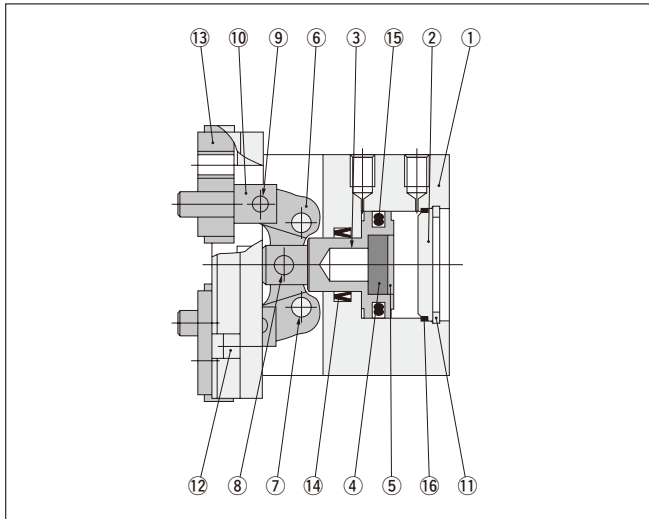

Major Parts and Materials

No.	Parts	Materials
①	Body	Aluminum alloy (nickel plated)
②	Head cover	Aluminum alloy
③	Piston rod	Stainless steel
④	Magnet	Plastic magnet
⑤	Magnet holder	Aluminum alloy
⑥	Action lever	Steel
⑦	Fulcrum pin	Steel
⑧	Press fit pin	Steel
⑨	Press fit pin	Steel
⑩	Knuckle	Stainless steel
⑪	Internal snap ring	Steel
⑫	Hexagon socket head bolt	Steel
⑬	Linear bearing	Stainless steel
⑭	Seal	Synthetic rubber (NBR)
⑮	Seal	Synthetic rubber (NBR)
⑯	O-ring	Synthetic rubber (NBR)

Order Codes

<p>NHC1 D - [] - [] [] []</p> <p>Air hand NHC1 Series</p>	<p>Bore size 10 : 10mm [0.394in.] 16 : 16mm [0.630in.] 20 : 20mm [0.787in.] 25 : 25mm [0.984in.]</p> <p>Operation type D : Double acting type</p>	<p>Number of sensor switches 1: With 1 sensor switch 2: With 2 sensor switches</p> <p>Lead wire length A : 1000mm [39in.] B : 3000mm [118in.]</p> <p>Sensor switch Blank : No sensor switch ZE135: 2-lead wire solid state type with indicator lamp Horizontal lead wire DC10~28V ZE155: 3-lead wire solid state type with indicator lamp Horizontal lead wire DC4.5~28V ZE235: 2-lead wire solid state type with indicator lamp Vertical lead wire DC10~28V ZE255: 3-lead wire solid state type with indicator lamp Vertical lead wire DC4.5~28V ● For details of sensor switches, see p.1544.</p>
---	--	--

Length of Sensor Switch Allowed to Protrude

The maximum length that the sensor switch protrudes from the body end surface (when the levers are completely closed) is as shown in the table below. Use these values for mounting the sensor.

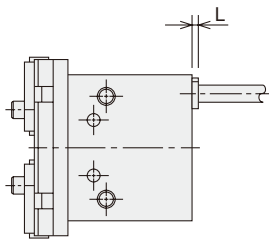

Model	Length of sensor switch allowed to protrude L
NHC1D-10	3 [0.12]
NHC1D-16	4 [0.16]
NHC1D-20	4 [0.16]
NHC1D-25	5 [0.20]

NHC1D-10

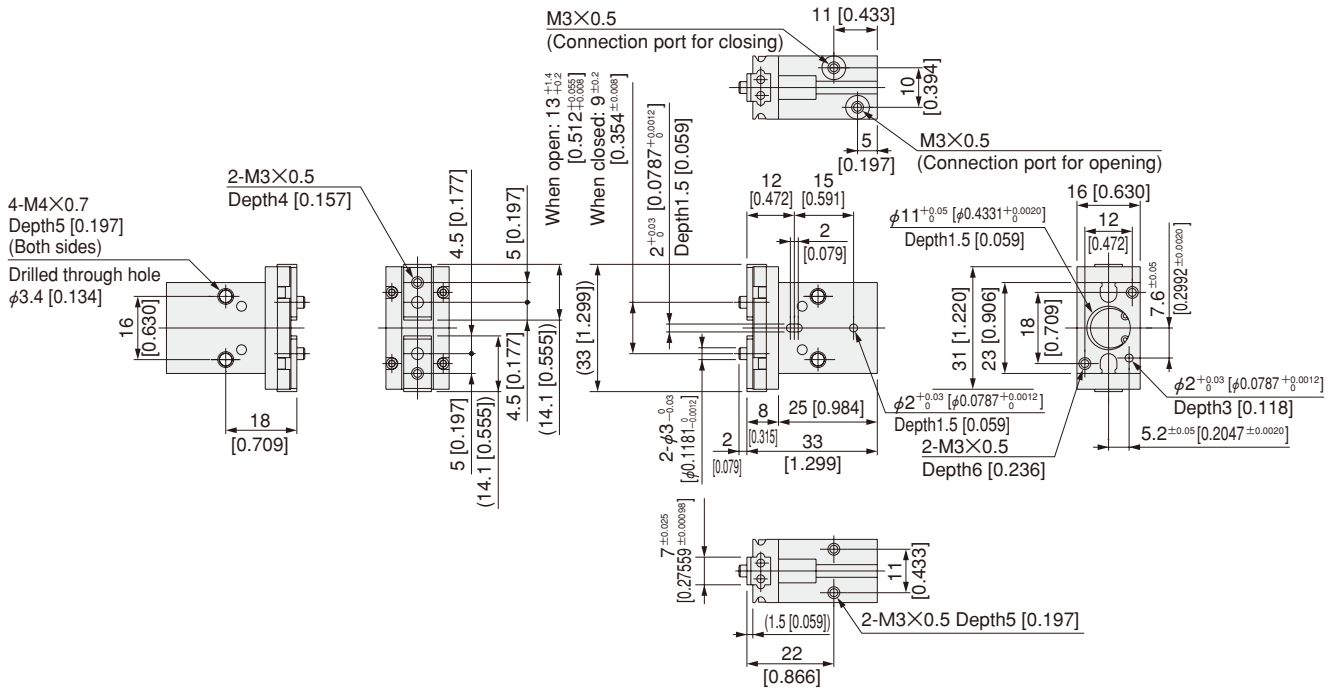

● The sensor switch is optional.
When mounting the sensor switch, always be sure to see the cautions for mounting on p.1460.

NHC1D-16

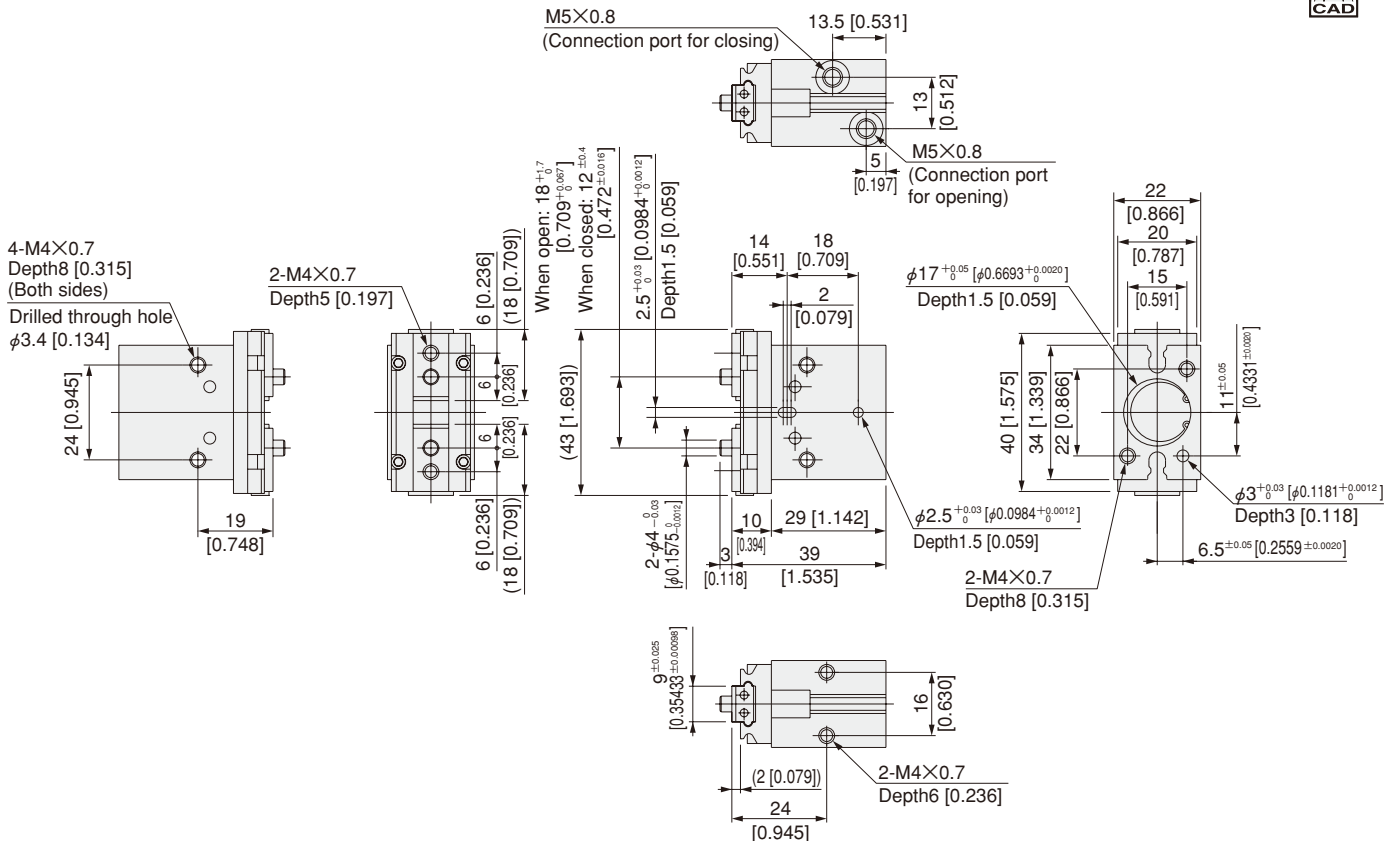

● The sensor switch is optional.
When mounting the sensor switch, always be sure to see the cautions for mounting on p.1460.

NHC1D-20

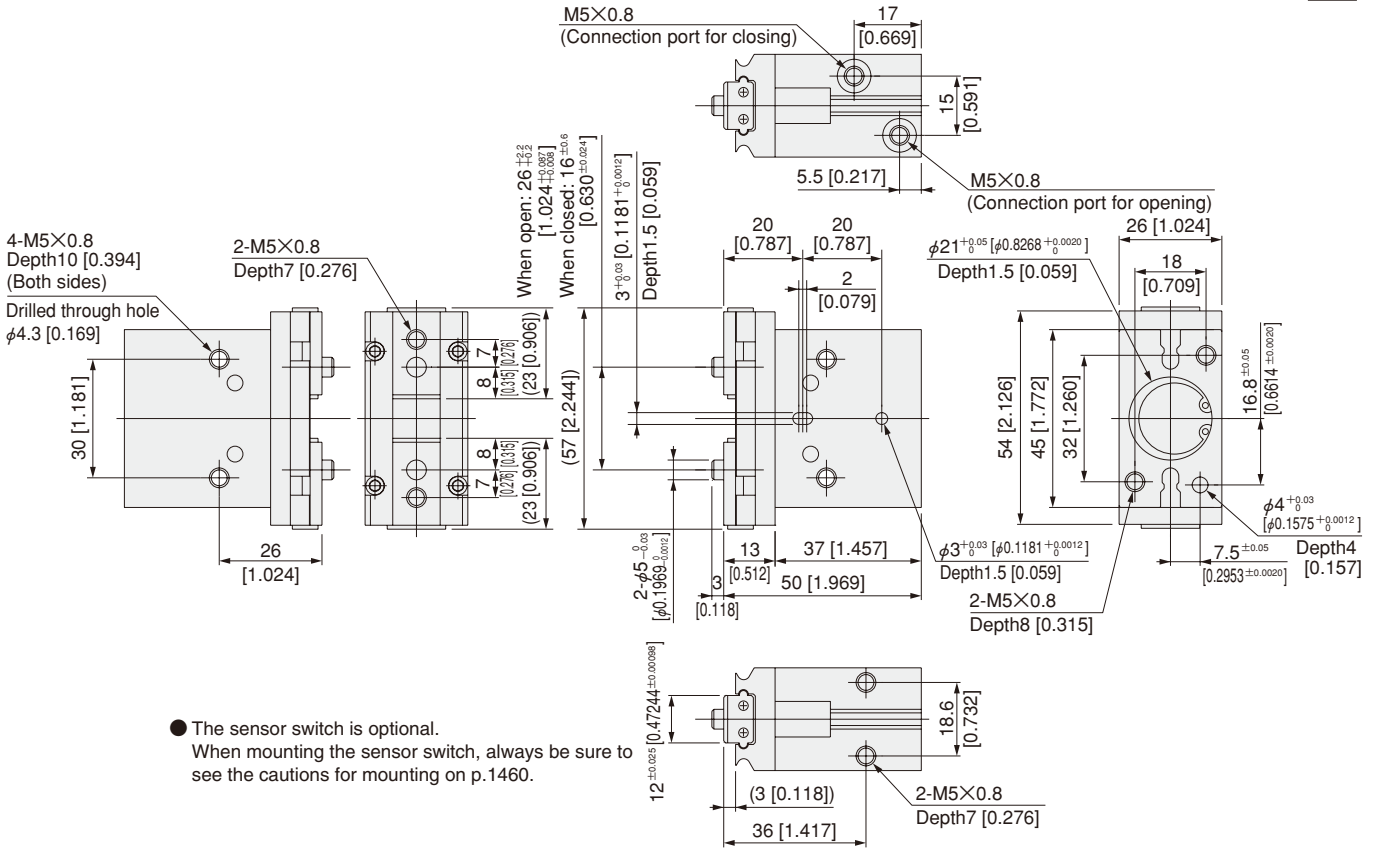

NHC1D-25

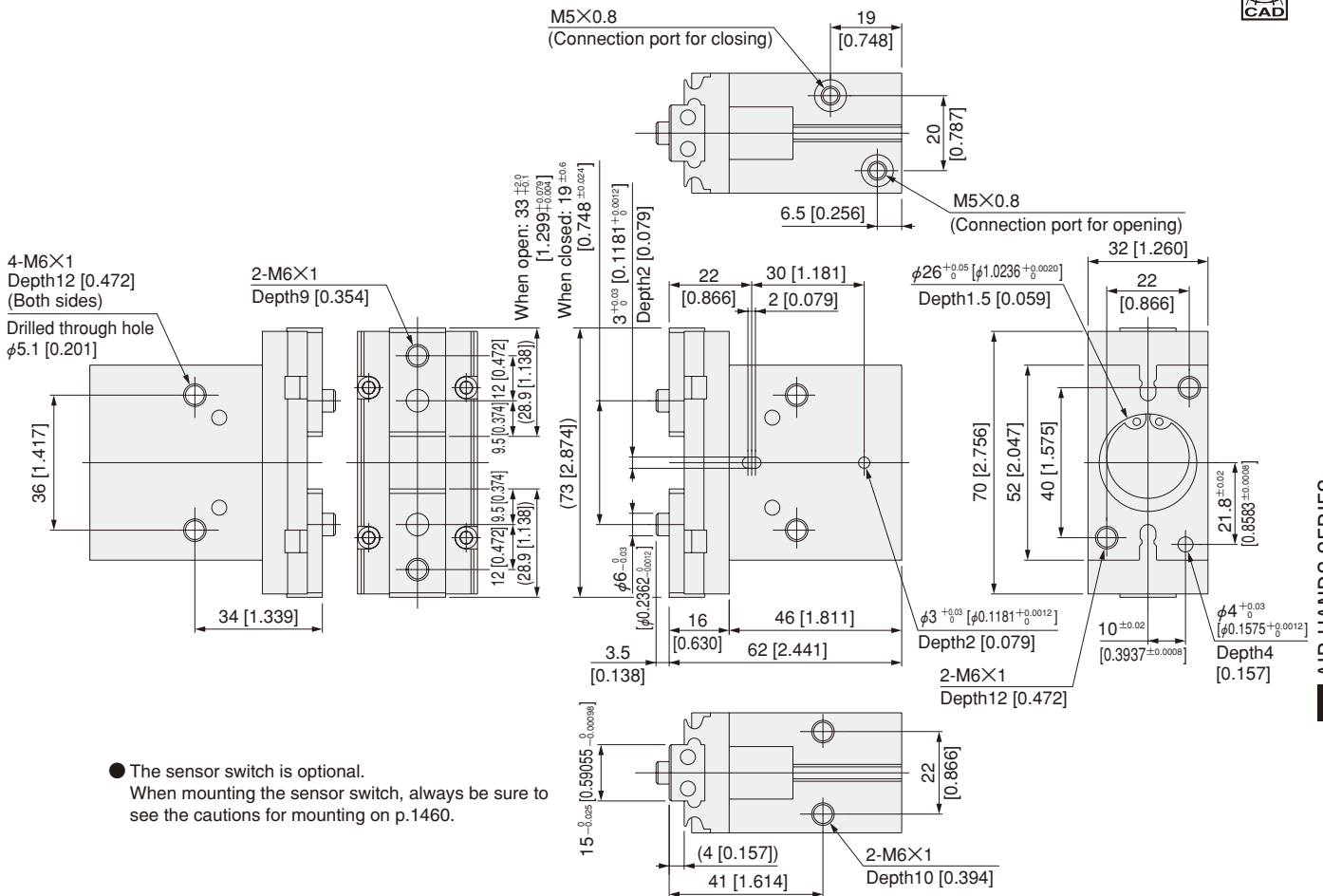

NHB SERIES PARALLEL TYPE

Linear Guide Specification
Double Acting Type, Single Acting Normally Open Type

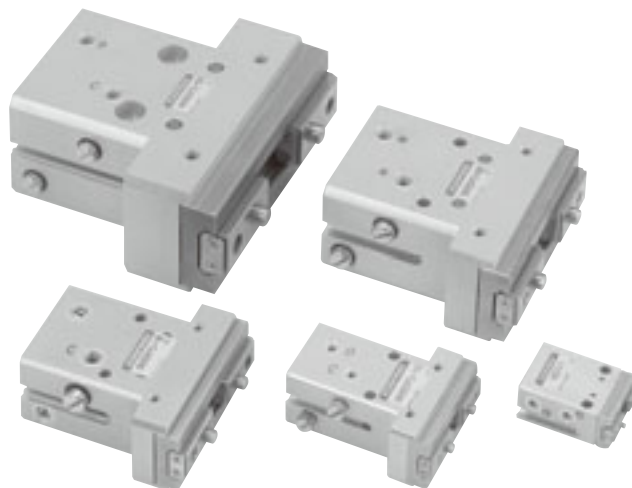

Symbols

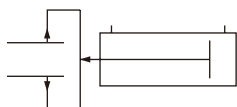

Double Acting Type

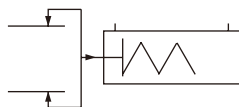

Single Acting
Normally Open Type

Specifications

● Double acting parallel type

Basic model		NHBDPG-8	NHBDPG-10	NHBDPG-16	NHBDPG-20	NHBDPG-32
Item						
Cylinder bore size	mm [in.]	8 [0.315]	10 [0.394]	16 [0.630]	20 [0.787]	32 [1.260]
Operation type		Double acting type				
Media		Air				
Operating pressure range	MPa [psi.]	0.22~0.7 [32~102]	0.2~0.7 [29~102]	0.12~0.7 [17~102]	0.1~0.7 [15~102]	
Proof pressure	MPa [psi.]	1.05 [152]				
Operating temperature range	°C [°F]	0~60 [32~140]				
Maximum operating frequency	cycle/min	120				
Lubrication		Not required				
Effective gripping force (F) ^{Note 1}	Closed side	5.8 [1.30]	9.4 [2.11]	26.4 [5.93]	45.0 [10.12]	157.8 [35.47]
	Open side	9.9 [2.23]	14.7 [3.30]	39.2 [8.81]	59.8 [13.44]	176.4 [39.65]
Lever open/closed stroke	mm [in.]	4 [0.157]	6.5 [0.256]	10 [0.394]	14 [0.551]	22 [0.866]
Repeatability	mm [in.]	±0.01 [±0.0004]				
Port size		M3×0.5			M5×0.8	
Mass ^{Note 2}	g [oz.]	24 [0.85] (29 [1.02])	80 [2.82] (91 [3.21])	159 [5.61] (178 [6.28])	329 [11.60] (355 [12.52])	664 [23.42]

Notes: 1. Values are obtained when grip point length is 30mm [1.18in.] under operating pressure 0.5 MPa [73psi.]. For details of the effective gripping force, see the graphs on p.1385.

2. () mean the mass with the mounting bracket: -M.

● Single acting normally open parallel type

Basic model		NHBRPG-8	NHBRPG-10	NHBRPG-16	NHBRPG-20
Item					
Cylinder bore size	mm [in.]	8 [0.315]	10 [0.394]	16 [0.630]	20 [0.787]
Operation type		Single acting normally open type			
Media		Air			
Operating pressure range	MPa [psi.]	0.4~0.7 [58~102]	0.35~0.7 [51~102]	0.25~0.7 [36~102]	
Proof pressure	MPa [psi.]	1.05 [152]			
Operating temperature range	°C [°F]	0~60 [32~140]			
Maximum operating frequency	cycle/min	120	80		
Lubrication		Not required			
Effective gripping force (F) ^{Note 1}	Closed side	4.1 [0.92]	6.8 [1.53]	19.6 [4.41]	34.3 [7.71]
	Open side	2.7 [0.61]	2.4 [0.54]	5.4 [1.21]	7.3 [1.64]
Lever open/closed stroke	mm [in.]	4 [0.157]	6.5 [0.256]	10 [0.394]	14 [0.551]
Repeatability	mm [in.]	±0.01 [±0.0004]			
Port size		M3×0.5		M5×0.8	
Mass ^{Note 2}	g [oz.]	24 [0.85] (29 [1.02])	81 [2.86] (92 [3.25])	160 [5.64] (179 [6.31])	330 [11.64] (356 [12.56])

Notes: 1. Values are obtained when grip point length is 30mm [1.18in.] under operating pressure 0.5 MPa [73psi.]. For details of the effective gripping force, see the graphs on p.1385.

2. () mean the mass with the mounting bracket: -M.

Inner Construction

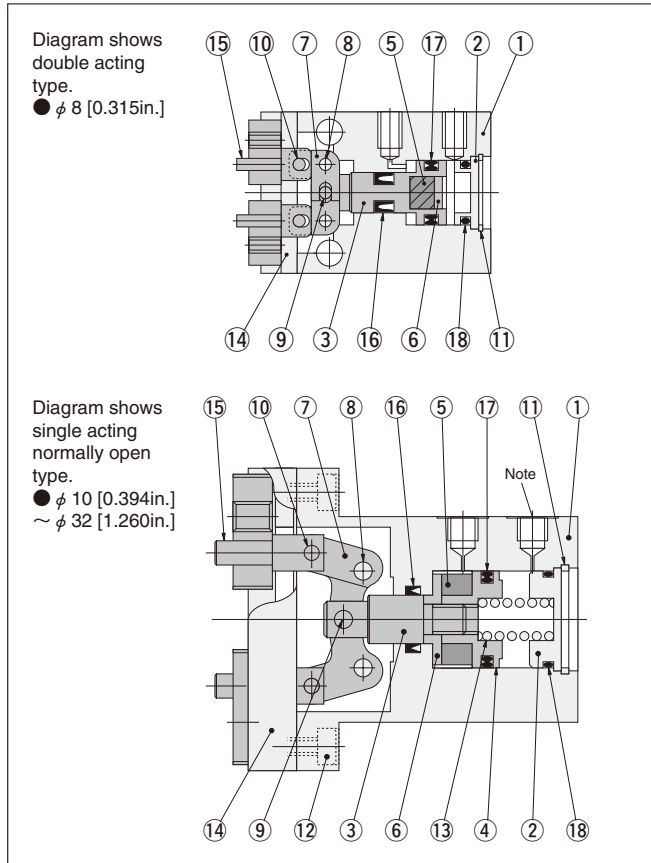

Note: An exhaust plug is attached to the exhaust connection port of the single acting normally open type (except $\phi 32$ [1.260in.]). Plugs are attached to the extra connection port on the side surface (except $\phi 8$ [0.315in.]).

Major Parts and Materials

No.	Parts	Materials	Remarks
①	Body	Aluminum alloy	
②	Head cover	Aluminum alloy	
③	Piston rod	Stainless steel	
④	Piston	Aluminum alloy	Except $\phi 8$ [0.315in.].
⑤	Magnet	Plastic magnet	
⑥	Magnet holder	Aluminum alloy	
⑦	Action lever	Steel	
⑧	Fulcrum pin	Steel	
⑨	Press fit pin	Steel	
⑩	Press fit pin	Steel	
⑪	Internal snap ring	Steel	
⑫	Hexagon socket head bolt	Steel	
⑬	Spring	Steel wire	Single acting type only
⑭	Bearing	Stainless steel	
⑮	Knuckle	Stainless steel	
⑯	Seal	Synthetic rubber (NBR)	
⑰	Seal	Synthetic rubber (NBR)	
⑱	O-ring	Synthetic rubber (NBR)	

Order Codes

	Basic model	Cylinder bore size	Sensor switch				Lead wire length	Number of sensor switches (for air hands with sensor switches)		
			Mounting bracket	No sensor switch	With ZE135	With ZE155			With ZE235	With ZE255
Double acting type	NHBDPG	-8 -10 -16 -20	Blank	Blank	-ZE135	-ZE155	-ZE235	-ZE255	A B	1 2
		-32								
Single acting normally open type	NHBRPG	-8 -10 -16 -20			-ZE135	-ZE155	-ZE235	-ZE255	A B	1 2

Mounting bracket

- No mounting bracket: Blank
- With mounting bracket: -M

★ Included at shipping

Sensor switch

- No sensor switch: Blank
- With ZE135: Solid state type, With indicator lamp, DC10~28V, 2-lead wire, Horizontal lead wire
- With ZE155: Solid state type, With indicator lamp, DC4.5~28V, 3-lead wire, Horizontal lead wire
- With ZE235: Solid state type, With indicator lamp, DC10~28V, 2-lead wire, Vertical lead wire
- With ZE255: Solid state type, With indicator lamp, DC4.5~28V, 3-lead wire, Vertical lead wire

Lead wire length

- A : 1000mm [39in.]
- B : 3000mm [118in.]

Number of sensor switches
(for air hands with sensor switches)

- 1 : With 1 sensor switch
- 2 : With 2 sensor switches

★ Included at shipping

Additional Parts (To be ordered separately)

Mounting bracket

- For $\phi 8$ [0.315in.] — NHB-M8
- For $\phi 10$ [0.394in.] — NHB-M10
- For $\phi 16$ [0.630in.] — NHB-M16
- For $\phi 20$ [0.787in.] — NHB-M20

Dimensions of Liner Guide Specification Parallel Type (mm)

NHB □ PG-8

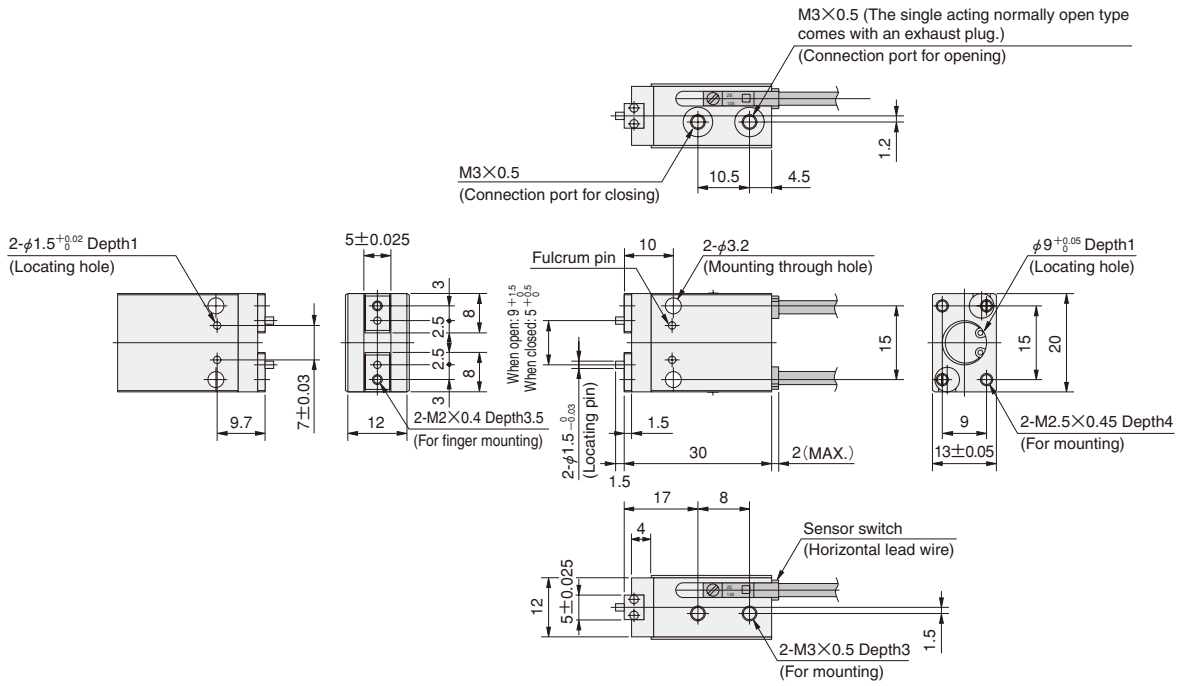

- The sensor switch is optional. When mounting the sensor switch, always be sure to see the cautions for mounting on p.1460.

Dimensions of Liner Guide Specification Parallel Type (mm)

NHB □ PG-10
NHB □ PG-16
NHB □ PG-20
NHBDPG-32



※ Drawings show $\phi 16$ [0.630in.].

Plugged (The single acting normally open type comes with an exhaust plug.)
 (Connection port for opening)

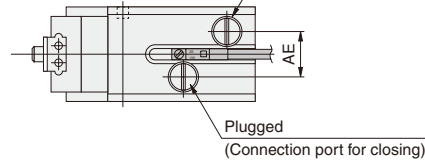

Plugged
 (Connection port for closing)

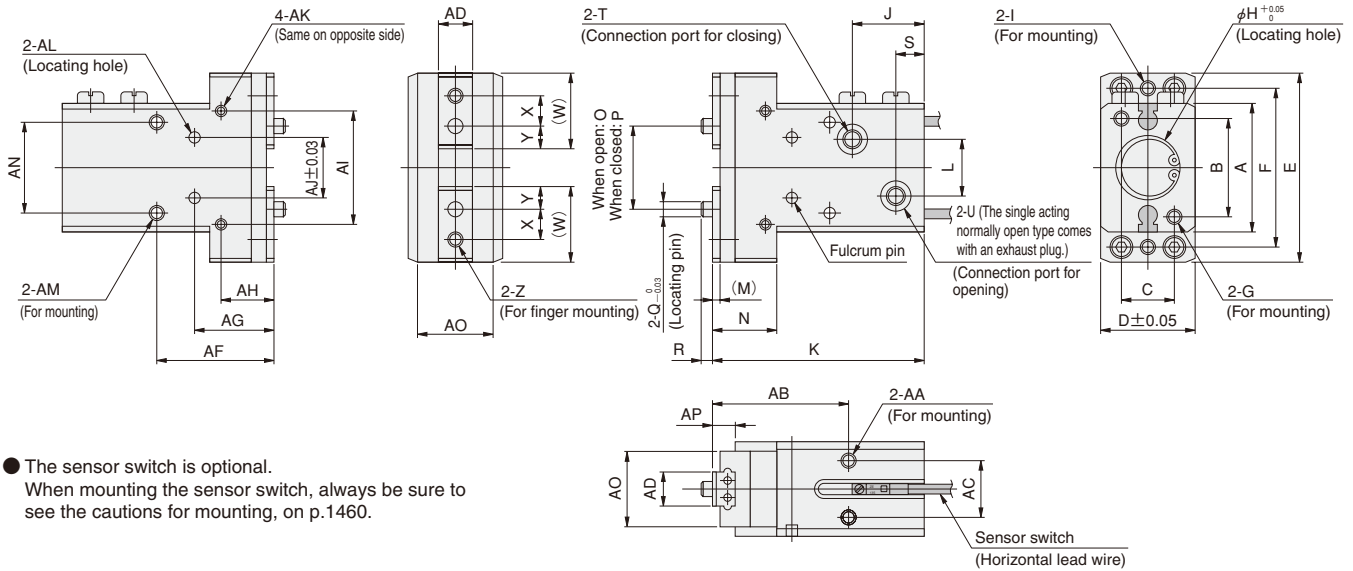

● The sensor switch is optional.
 When mounting the sensor switch, always be sure to see the cautions for mounting, on p.1460.

Model	Code	A	B	C	D	E	F	G	H	I	J	K	L	M
NHB □ PG-10		23	17	10	20	36	30	M3×0.5 Depth 6	11 Depth 1.5	M3×0.5 Depth 4.5	17	49	7	1.5
NHB □ PG-16		34	26	14	25	50	42	M4×0.7 Depth 7	17 Depth 1.5	M4×0.7 Depth 5	19	56	15	2
NHB □ PG-20		45	35	16	32	62	54	M5×0.8 Depth 9	21 Depth 1.5	M4×0.7 Depth 7	21	67	17	3
NHBDPG-32		52	40	30	40	85	70	M6×1 Depth 9	34 Depth 2	M6×1 Depth 9	28.5	83	20	4

N	O	P	Q	R	S	T	U	W	X	Y	Z	AA	AB	AC
14	15.5 $^{+0.8}_0$	9 $^{+0.5}_0$	$\phi 3$	2	7.5	M3×0.5	M3×0.5	14.7	5	4.5	M3×0.5 Depth 4	M3×0.5 Depth 5	29	12
17	22 $^{+1.8}_0$	12 $^{+1.3}_0$	$\phi 4$	3	7.5	M5×0.8	M5×0.8	20	8	6	M4×0.7 Depth 5	M4×0.7 Depth 6	36	15
23	30 $^{+2.9}_0$	16 $^{+1.4}_0$	$\phi 5$	3	7.5	M5×0.8	M5×0.8	24	8	8	M5×0.8 Depth 7	M5×0.8 Depth 8	43	18
35	41 $^{+1.8}_0$	19 $^{+1.3}_0$	$\phi 6$	3.5	9	M5×0.8	M5×0.8	31	14	9.5	M6×1 Depth 9	M6×1 Depth 8	53	20

AD	AE	AF	AG	AH	AI	AJ	AK	AL	AM	AN	AO	AP
7 ± 0.025	9	24	16	11	20	12	M3×0.5 Depth 5	$\phi 2.5^{+0.02}_0$ Depth 2.5	M4×0.7 Depth 6, Drilled hole diameter $\phi 3.4$ thru hole	17	17	6
9 ± 0.025	12	31	21	14	30	16	M3×0.5 Depth 5	$\phi 3^{+0.02}_0$ Depth 3	M4×0.7 Depth 6, Drilled hole diameter $\phi 3.4$ thru hole	24	20	8
12 ± 0.025	16	37	27.3	17	40	22	M4×0.7 Depth 6	$\phi 4^{+0.02}_0$ Depth 3.5	M4×0.8 Depth 8, Drilled hole diameter $\phi 4.2$ thru hole	30	27	10
15 $^{0}_{-0.025}$	20	46	31	20	50	30	M5×0.8 Depth 8	$\phi 5^{+0.03}_0$ Depth 4	M6×1 Depth 9, Drilled hole diameter $\phi 5.2$ thru hole, $\phi 9.5$ Counterbore Depth 6 (back side)	30	32	13

Options

● Mounting bracket: -M

NHB-M8

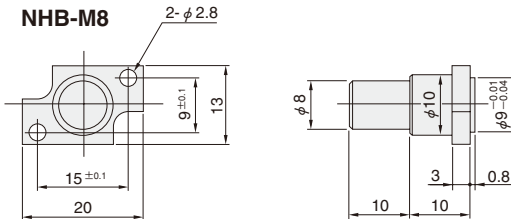

NHB-M10~20

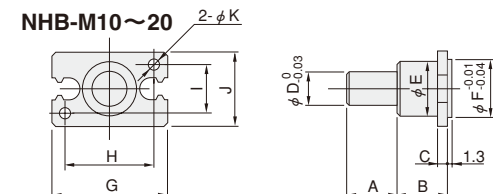

Model	Code	A	B	C	D	E	F	G	H	I	J	K
NHB-M10		15	15	3	10	11	11	23	17	10	16	3.4
NHB-M16		15	15	3	10	16	17	34	26	14	22	4.5
NHB-M20		15	15	3	10	18	21	45	35	16	26	5.5

NHB SERIES PARALLEL TYPE

Linear Guide Specification Long Stroke Double Acting Type

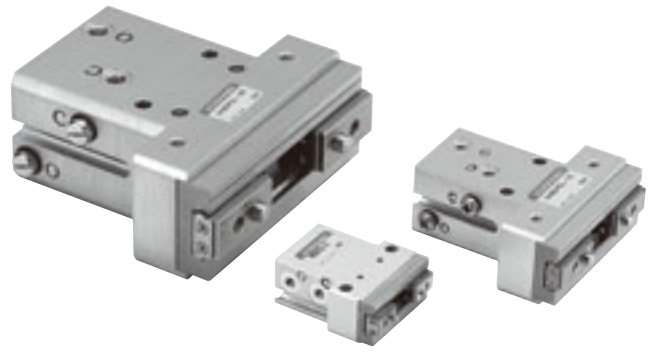

Symbol

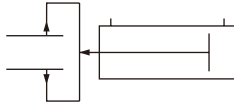

Specifications

Basic model		NHBDPGL-8	NHBDPGL-10	NHBDPGL-16	NHBDPGL-20
Cylinder bore size	mm [in.]	8 [0.315]	10 [0.394]	16 [0.630]	20 [0.787]
Operation type		Double acting type			
Media		Air			
Operating pressure range	MPa [psi.]	0.22~0.7 [32~102]	0.2~0.7 [29~102]	0.12~0.7 [17~102]	0.1~0.7 [15~102]
Proof pressure	MPa [psi.]	1.05 [152]			
Operating temperature range	°C [°F]	0~60 [32~140]			
Maximum operating frequency	cycle/min	120			
Lubrication		Not required			
Effective gripping force (F) ^{Note 1}	Closed side	5.8 [1.30]	9.4 [2.11]	26.4 [5.93]	45.0 [10.12]
	Open side	9.9 [2.23]	14.7 [3.30]	39.2 [8.81]	59.8 [13.44]
Lever open/closed stroke	mm [in.]	8 [0.315]	12 [0.472]	16 [0.630]	22 [0.866]
Repeatability	mm [in.]	±0.01 [±0.0004]			
Port size		M3×0.5		M5×0.8	
Mass ^{Note 2}	g [oz.]	27 [0.95] (32 [1.13])	90 [3.17] (101 [3.56])	168 [5.93] (187 [6.60])	368 [12.98] (394 [13.90])

Notes: 1. Values are obtained when grip point length is 30mm [1.18in.] under operating pressure 0.5 MPa [73psi.]. For details of the effective gripping force, see the graphs on p.1385.

2. () mean the mass with the mounting bracket: **-M**.

Inner Construction

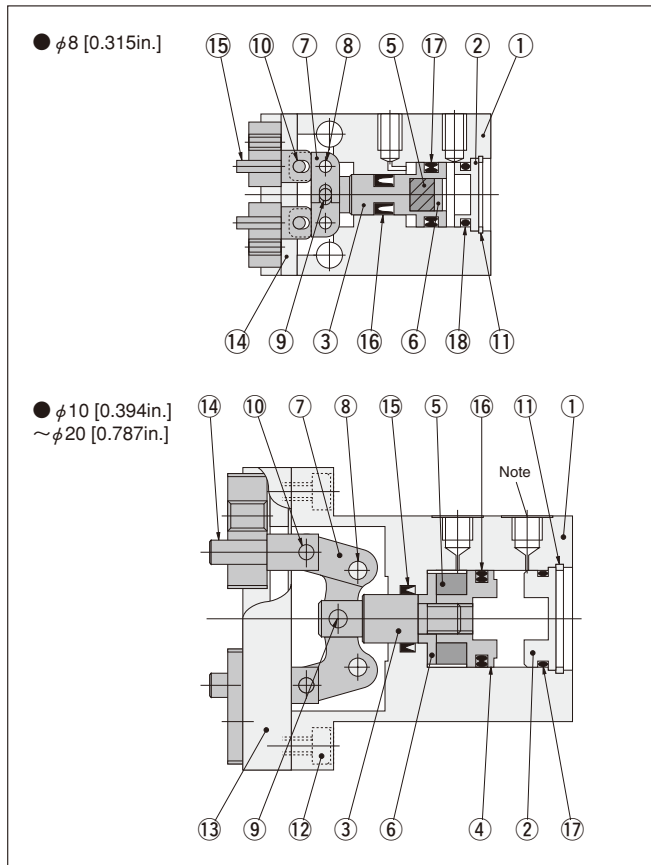

Note: Plugs are attached to the extra connection ports on the side surface (except φ8 [0.135in.]).

Major Parts and Materials

No.	Parts	Materials	Remarks
①	Body	Aluminum alloy	
②	Head cover	Aluminum alloy	
③	Piston rod	Stainless steel	
④	Piston	Aluminum alloy	Except φ8 [0.315in.].
⑤	Magnet	Plastic magnet	
⑥	Magnet holder	Aluminum alloy	
⑦	Action lever	Steel	
⑧	Fulcrum pin	Steel	
⑨	Press fit pin	Steel	
⑩	Press fit pin	Steel	
⑪	Internal snap ring	Steel	
⑫	Hexagon socket head bolt	Steel	
⑬	Bearing	Stainless steel	
⑭	Knuckle	Stainless steel	
⑮	Seal	Synthetic rubber (NBR)	
⑯	Seal	Synthetic rubber (NBR)	
⑰	O-ring	Synthetic rubber (NBR)	

Order Codes

Double Acting Type	Basic model	Cylinder bore size	-M	-ZE135 -ZE155 -ZE235 -ZE255	A B	1 2
	NHBDPGL	-8 -10 -16 -20				

Mounting bracket

No mounting bracket

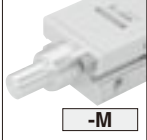
Blank

With mounting bracket

-M

★ Included at shipping

Sensor switch

No sensor switch

Blank

With ZE135

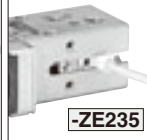
-ZE135

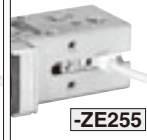
With ZE155

-ZE155

With ZE235

-ZE235

With ZE255

-ZE255

● Solid state type
● With indicator lamp
● DC10~28V
● 2-lead wire
● Horizontal lead wire

● Solid state type
● With indicator lamp
● DC4.5~28V
● 3-lead wire
● Horizontal lead wire

● Solid state type
● With indicator lamp
● DC10~28V
● 2-lead wire
● Vertical lead wire

● Solid state type
● With indicator lamp
● DC4.5~28V
● 3-lead wire
● Vertical lead wire

Lead wire length

A : 1000mm [39in.]
B : 3000mm [118in.]

Number of sensor switches
(for air hands with sensor switches)

● 1 : With 1 sensor switch
● 2 : With 2 sensor switches

★ Included at shipping

Additional Parts (To be ordered separately)

Mounting bracket

● For φ8 [0.315in.]
—NHB-M8

● For φ10 [0.394in.]
—NHB-M10

● For φ16 [0.630in.]
—NHB-M16

● For φ20 [0.787in.]
—NHB-M20

NHBDPGL-8

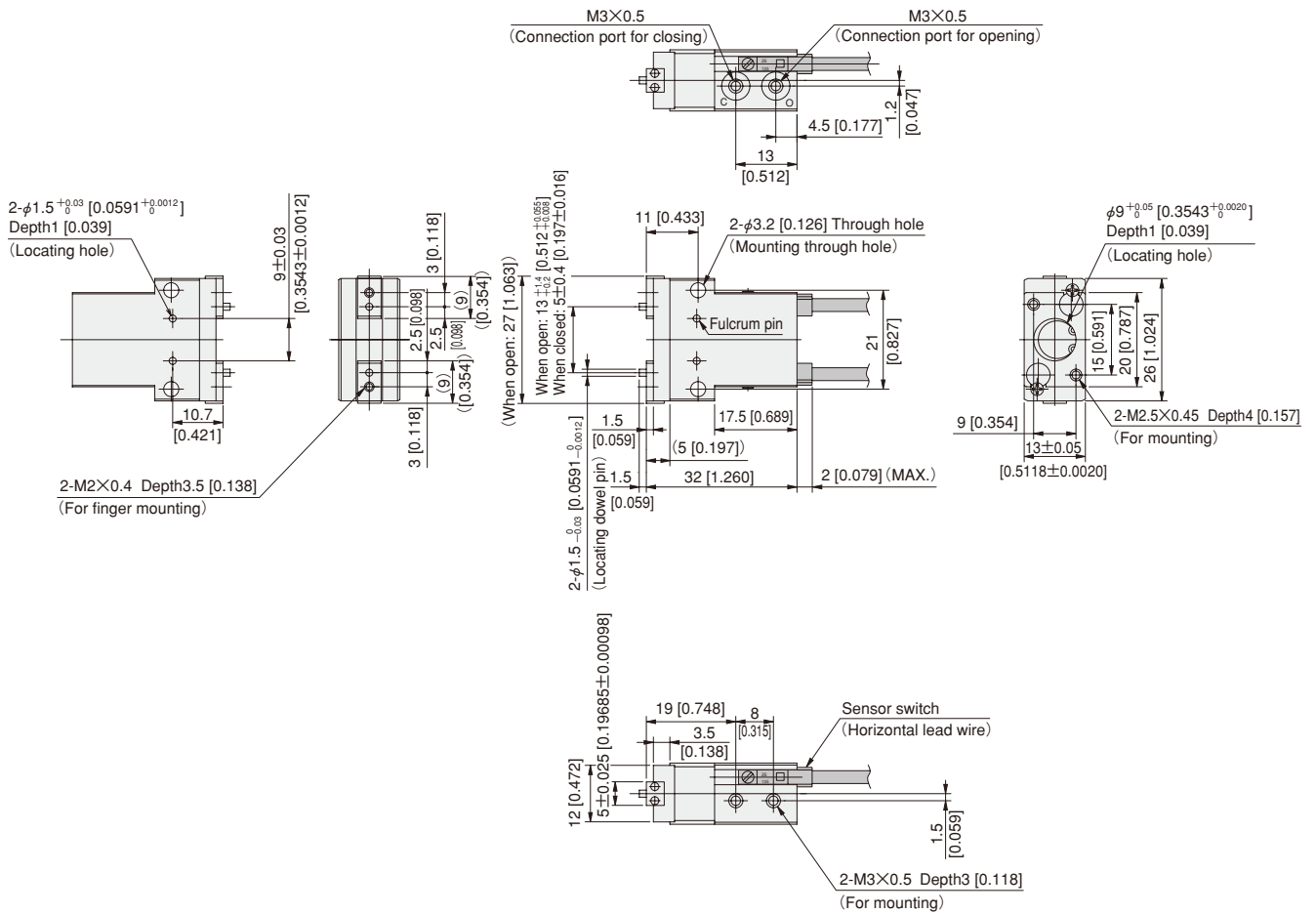

● The sensor switch is optional.
When mounting the sensor switch, always be sure to see the cautions for mounting on p.1460.

Options

● Mounting bracket: -M

NHB-M8

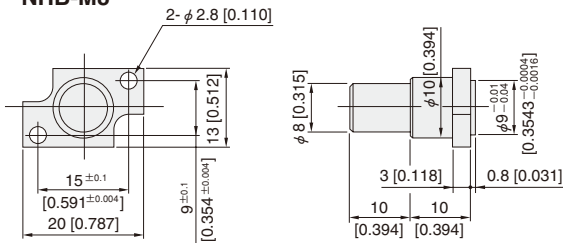

NHB-M10~20

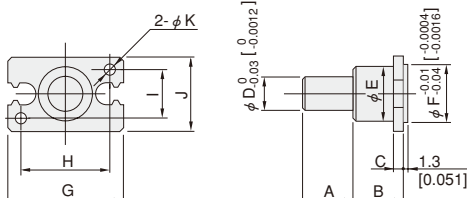

Model	Code	A	B	C	D	E	F	G	H	I	J	K
NHB-M10		15	15	3	10	11	11	23	17	10	16	3.4
		[0.591]	[0.591]	[0.118]	[0.3937]	[0.433]	[0.4331]	[0.906]	[0.669]	[0.394]	[0.630]	[0.134]
NHB-M16		15	15	3	10	16	17	34	26	14	22	4.5
		[0.591]	[0.591]	[0.118]	[0.3937]	[0.630]	[0.6693]	[1.339]	[1.024]	[0.551]	[0.866]	[0.177]
NHB-M20		15	15	3	10	18	21	45	35	16	26	5.5
		[0.591]	[0.591]	[0.118]	[0.3937]	[0.709]	[0.8268]	[1.772]	[1.378]	[0.630]	[1.024]	[0.217]



NHBDPGL-10
NHBDPGL-16
NHBDPGL-20

※ Drawings show $\phi 16$ [0.630in.].

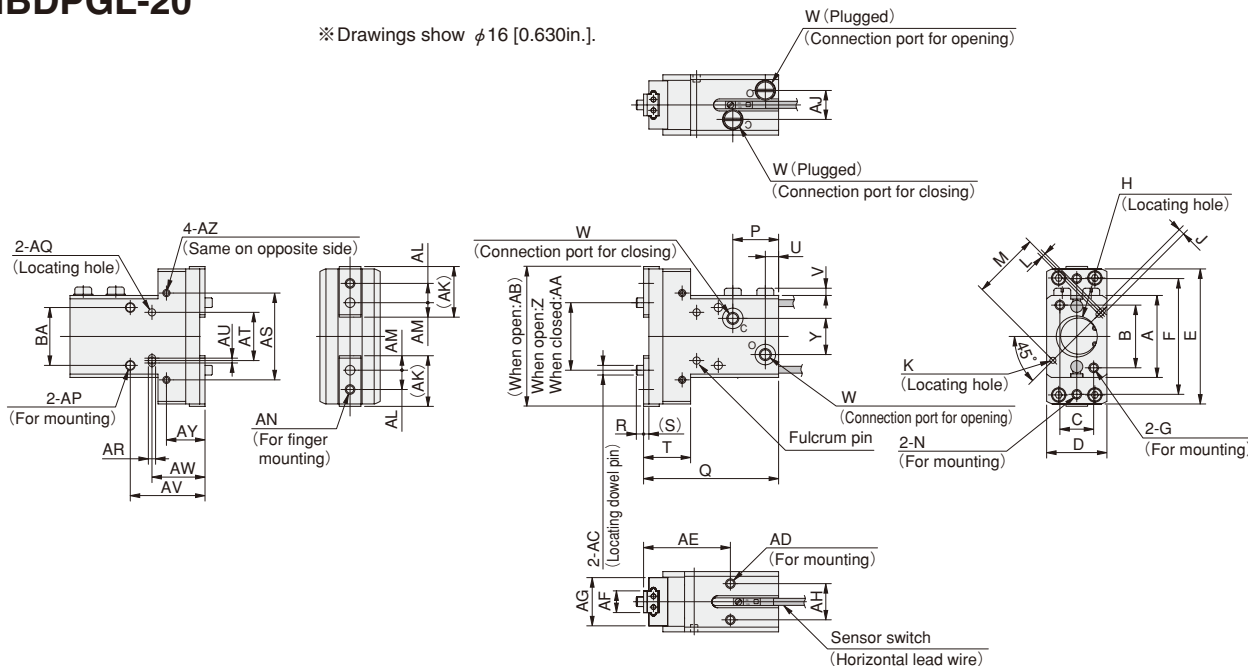

● The sensor switch is optional.
When mounting the sensor switch, always be sure to see the cautions for mounting on p.1460.

Model	Code	A	B	C	D	E	F	G	H	J	K	L	M	N						
NHBDPGL-10		23 [0.906]	17 [0.669]	10 [0.394]	20±0.05 [0.7874 ±0.0020]	45 [1.772]	39 [1.535]	M3×0.5 Depth6 [0.236]	$\phi 11^{+0.05}_0$ [0.4331 ^{+0.0020} Depth1.5 [0.059]	$2^{+0.03}_0$ [0.0787 ^{+0.0012} Depth2 [0.079]	$\phi 2^{+0.03}_0$ [0.0787 ^{+0.0012} Depth2 [0.079]	1 [0.039]	20 [0.787]	M3×0.5 Depth4.5 [0.177]						
NHBDPGL-16		34 [1.339]	26 [1.024]	14 [0.551]	25±0.05 [0.9843 ±0.0020]	56 [2.205]	48 [1.890]	M4×0.7 Depth7 [0.276]	$\phi 17^{+0.05}_0$ [0.6693 ^{+0.0020} Depth1.5 [0.059]	$2.5^{+0.03}_0$ [0.0984 ^{+0.0012} Depth3 [0.118]	$\phi 2.5^{+0.03}_0$ [0.0984 ^{+0.0012} Depth3 [0.118]	2 [0.079]	28 [1.102]	M4×0.7 Depth5 [0.197]						
NHBDPGL-20		45 [1.772]	35 [1.378]	16 [0.630]	32±0.05 [1.2598 ±0.0020]	73 [2.874]	65 [2.559]	M5×0.8 Depth9 [0.354]	$\phi 21^{+0.05}_0$ [0.8268 ^{+0.0020} Depth1.5 [0.059]	$3^{+0.03}_0$ [0.1181 ^{+0.0012} Depth3 [0.118]	$\phi 3^{+0.03}_0$ [0.1181 ^{+0.0012} Depth3 [0.118]	2 [0.079]	34 [1.339]	M5×0.7 Depth7 [0.276]						
P	Q	R	S	T	U	V	W	Y	Z	AA	AB	AC	AD	AE	AF	AG	AH	AJ	AK	AL
17 [0.669]	49 [1.929]	2 [0.079]	1.5 [0.059]	18 [0.709]	5 [0.197]	2.5 [0.098]	M3×0.5	7 [0.276]	$21^{+1.5}_0$ [0.827 ^{+0.059} ±0.020]	$9^{+0.5}_0$ [0.354 ^{+0.020} ±0.012]	46 [1.811]	$\phi 3^{+0.03}_0$ [0.1181 ^{+0.0012} ±0.0012]	M3×0.5 Depth5 [0.197]	29 [1.142]	7 ± 0.025 [0.27559 ±0.00098]	17 [0.669]	12 [0.472]	10 [0.394]	16.8 [0.661]	5 [0.197]
19 [0.748]	56 [2.205]	3 [0.118]	2.2 [0.087]	19.5 [0.768]	5.5 [0.217]	3 [0.118]	M5×0.8	15 [0.591]	$28^{+1.8}_0$ [1.102 ^{+0.071} ±0.051]	$12^{+1.3}_0$ [0.472 ^{+0.051} ±0.020]	59 [2.323]	$\phi 4^{+0.03}_0$ [0.1575 ^{+0.0012} ±0.0012]	M4×0.7 Depth6 [0.236]	36 [1.417]	9 ± 0.025 [0.35433 ±0.00098]	20 [0.787]	15 [0.591]	12 [0.472]	21 [0.827]	8 [0.315]
23 [0.906]	73 [2.874]	3 [0.118]	3 [0.118]	26 [1.024]	5.5 [0.217]	3 [0.118]	M5×0.8	17 [0.669]	$38^{+2.4}_0$ [1.496 ^{+0.094} ±0.020]	$16^{+1.4}_0$ [0.630 ^{+0.055} ±0.020]	75 [2.953]	$\phi 5^{+0.03}_0$ [0.1969 ^{+0.0012} ±0.0012]	M5×0.8 Depth8 [0.315]	43 [1.693]	12 ± 0.025 [0.47244 ±0.00098]	27 [1.063]	18 [0.709]	15 [0.591]	26 [1.024]	8 [0.315]
AM	AN	AP	AQ	AR	AS	AT	AU	AV	AW	AY	AZ	BA								
4.5 [0.177]	M3×0.5 Depth4 [0.157]	M4×0.7 Depth6 [0.236], Drilled hole diameter $\phi 3.4$ [0.134] through hole	$\phi 2.5^{+0.02}_0$ [0.0984 ^{+0.0008} Depth2.5 [0.098]	$2.5^{+0.02}_0$ [0.0984 ^{+0.0008} Depth2.5 [0.098]	30 [1.181]	14 ± 0.03 [0.5512 ±0.0012]	1 [0.039]	24 [0.945]	17 [0.669]	12 [0.472]	M3×0.5 Depth5 [0.197]	17 [0.669]								
6 [0.236]	M4×0.7 Depth5 [0.197]	M4×0.7 Depth6 [0.236], Drilled hole diameter $\phi 3.4$ [0.134] through hole	$\phi 3^{+0.02}_0$ [0.1181 ^{+0.0008} Depth3 [0.118]	$3^{+0.02}_0$ [0.1181 ^{+0.0008} Depth3 [0.118]	36 [1.417]	20 ± 0.03 [0.7874 ±0.0012]	2 [0.079]	31 [1.220]	22 [0.866]	16 [0.630]	M3×0.5 Depth5 [0.197]	24 [0.945]								
8 [0.315]	M5×0.8 Depth7 [0.276]	M5×0.8 Depth8 [0.315], Drilled hole diameter $\phi 4.2$ [0.165] through hole	$\phi 4^{+0.02}_0$ [0.1575 ^{+0.0008} Depth3.5 [0.138]	$4^{+0.02}_0$ [0.1575 ^{+0.0008} Depth3.5 [0.138]	50 [1.969]	26 ± 0.03 [1.0236 ±0.0012]	2 [0.079]	37 [1.457]	27.3 [1.075]	20 [0.787]	M4×0.7 Depth6 [0.236]	30 [1.181]								

NHB SERIES PARALLEL TYPE

Linear Guide Specification with Fingers
Double Acting Type, Single Acting Normally Open Type

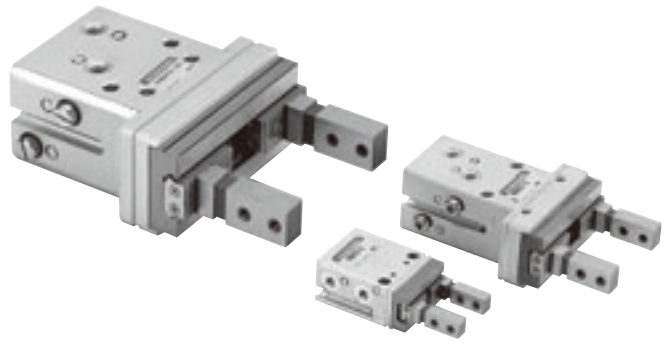

Symbols

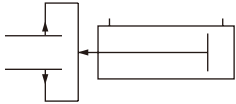

Double Acting Type

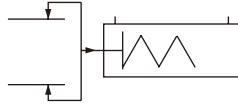

Single Acting
Normally Open Type

Specifications

● Double acting type

Basic model		NHBDPGY-8	NHBDPGY-10	NHBDPGY-16	NHBDPGY-20
Item					
Cylinder bore size	mm [in.]	8 [0.315]	10 [0.394]	16 [0.630]	20 [0.787]
Operation type		Double acting type			
Media		Air			
Operating pressure range	MPa [psi.]	0.22~0.7 [32~102]	0.2~0.7 [29~102]	0.12~0.7 [17~102]	0.1~0.7 [15~102]
Proof pressure	MPa [psi.]	1.05 [152]			
Operating temperature range	°C [°F]	0~60 [32~140]			
Maximum operating frequency	cycle/min	100			
Lubrication		Not required			
Effective gripping force (F) ^{Note 1}	Closed side	5.8 [1.30]	9.4 [2.11]	26.4 [5.93]	45.0 [10.12]
	Open side	9.9 [2.23]	14.7 [3.30]	39.2 [8.81]	59.8 [13.44]
Lever open/closed stroke	mm [in.]	4 [0.157]	6.5 [0.256]	10 [0.394]	14 [0.551]
Repeatability	mm [in.]	±0.01 [±0.0004]			
Port size		M3×0.5		M5×0.8	
Mass ^{Note 2}	g [oz.]	27 [0.95] (32 [1.13])	90 [3.17] (101 [3.56])	180 [6.35] (119 [4.20])	370 [13.05] (396 [13.97])

Notes: 1. Values are obtained when grip point length is 30mm [1.18in.] under operating pressure 0.5 MPa [73psi.]. For details of the effective gripping force, see the graphs on p.1386.

2. () mean the mass with the mounting bracket: -M.

● Single acting normally open parallel type

Basic model		NHBRPGY-8	NHBRPGY-10	NHBRPGY-16	NHBRPGY-20
Item					
Cylinder bore size	mm [in.]	8 [0.315]	10 [0.394]	16 [0.630]	20 [0.787]
Operation type		Single acting normally open type			
Media		Air			
Operating pressure range	MPa [psi.]	0.4~0.7 [58~102]	0.35~0.7 [51~102]	0.25~0.7 [36~102]	
Proof pressure	MPa [psi.]	1.05 [152]			
Operating temperature range	°C [°F]	0~60 [32~140]			
Maximum operating frequency	cycle/min	100			
Lubrication		Not required			
Effective gripping force (F) ^{Note 1}	Closed side	4.1 [0.92]	6.8 [1.53]	20.0 [4.50]	34.0 [7.64]
	Open side	2.7 [0.61]	2.4 [0.54]	5.4 [1.21]	7.3 [1.64]
Lever open/closed stroke	mm [in.]	4 [0.157]	6.5 [0.256]	10 [0.394]	14 [0.551]
Repeatability	mm [in.]	±0.01 [±0.0004]			
Port size		M3×0.5		M5×0.8	
Mass ^{Note 2}	g [oz.]	28 [0.99] (33 [1.16])	91 [3.21] (102 [3.60])	181 [6.38] (200 [7.05])	371 [13.09] (397 [14.00])

Notes: 1. Values are obtained when grip point length is 30mm [1.18in.] under operating pressure 0.5 MPa [73psi.]. For details of the effective gripping force, see the graphs on p.1386.

2. () mean the mass with the mounting bracket: -M.

Inner Construction

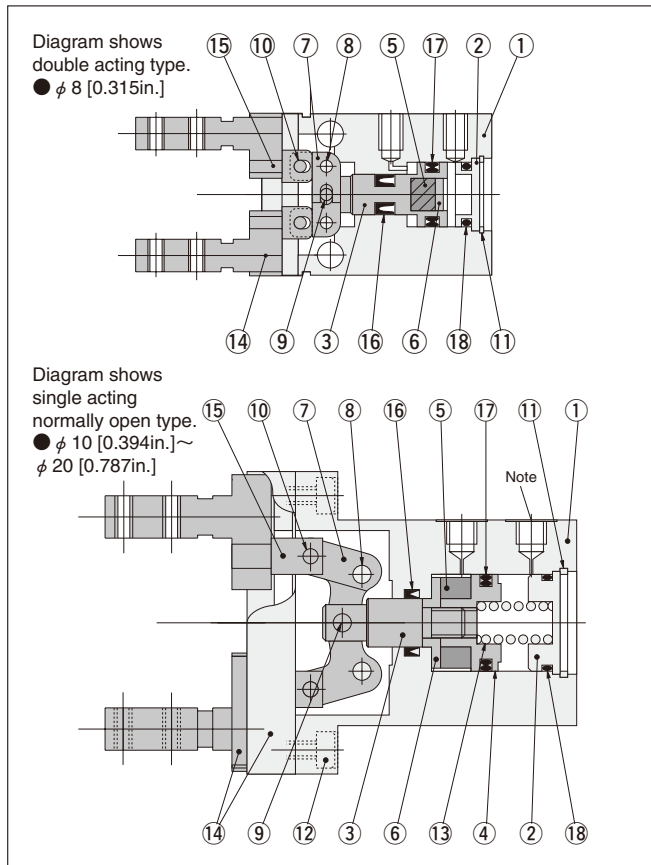

Major Parts and Materials

No.	Parts	Materials	Remarks
①	Body	Aluminum alloy	
②	Head cover	Aluminum alloy	
③	Piston rod	Stainless steel	
④	Piston	Aluminum alloy	Except ϕ 8 [0.315in.].
⑤	Magnet	Plastic magnet	
⑥	Magnet holder	Aluminum alloy	
⑦	Action lever	Steel	
⑧	Fulcrum pin	Steel	
⑨	Press fit pin	Steel	
⑩	Press fit pin	Steel	
⑪	Internal snap ring	Steel	
⑫	Hexagon socket head bolt	Steel	
⑬	Spring	Steel wire	Single acting type only
⑭	Bearing	Stainless steel	
⑮	Knuckle	Stainless steel	
⑯	Seal	Synthetic rubber (NBR)	
⑰	Seal	Synthetic rubber (NBR)	
⑱	O-ring	Synthetic rubber (NBR)	

Order Codes

	Mounting bracket		Sensor switch				Lead wire length	Number of sensor switches (for air hands with sensor switches)
	No mounting bracket	With mounting bracket	No sensor switch	With ZE135	With ZE155	With ZE235		
	Blank	-M	Blank	-ZE135	-ZE155	-ZE235	-ZE255	
		★ Included at shipping		<ul style="list-style-type: none"> ● Solid state type ● With indicator lamp ● DC10~28V ● 2-lead wire ● Horizontal lead wire 	<ul style="list-style-type: none"> ● Solid state type ● With indicator lamp ● DC4.5~28V ● 3-lead wire ● Horizontal lead wire 	<ul style="list-style-type: none"> ● Solid state type ● With indicator lamp ● DC10~28V ● 2-lead wire ● Vertical lead wire 	<ul style="list-style-type: none"> ● Solid state type ● With indicator lamp ● DC4.5~28V ● 3-lead wire ● Vertical lead wire 	
	Basic model		Cylinder bore size					
Double acting type	NHBDPGY		-8 -10 -16 -20		-M	-ZE135 -ZE155 -ZE235 -ZE255	A B	1 2
Single acting normally open type	NHBRPGY		-8 -10 -16 -20		-M	-ZE135 -ZE155 -ZE235 -ZE255	A B	1 2

Additional Parts (To be ordered separately)

Mounting bracket

- For ϕ 8 [0.315in.] - NHB-M8
- For ϕ 10 [0.394in.] - NHB-M10
- For ϕ 16 [0.630in.] - NHB-M16
- For ϕ 20 [0.787in.] - NHB-M20

NHB □ PGY-8

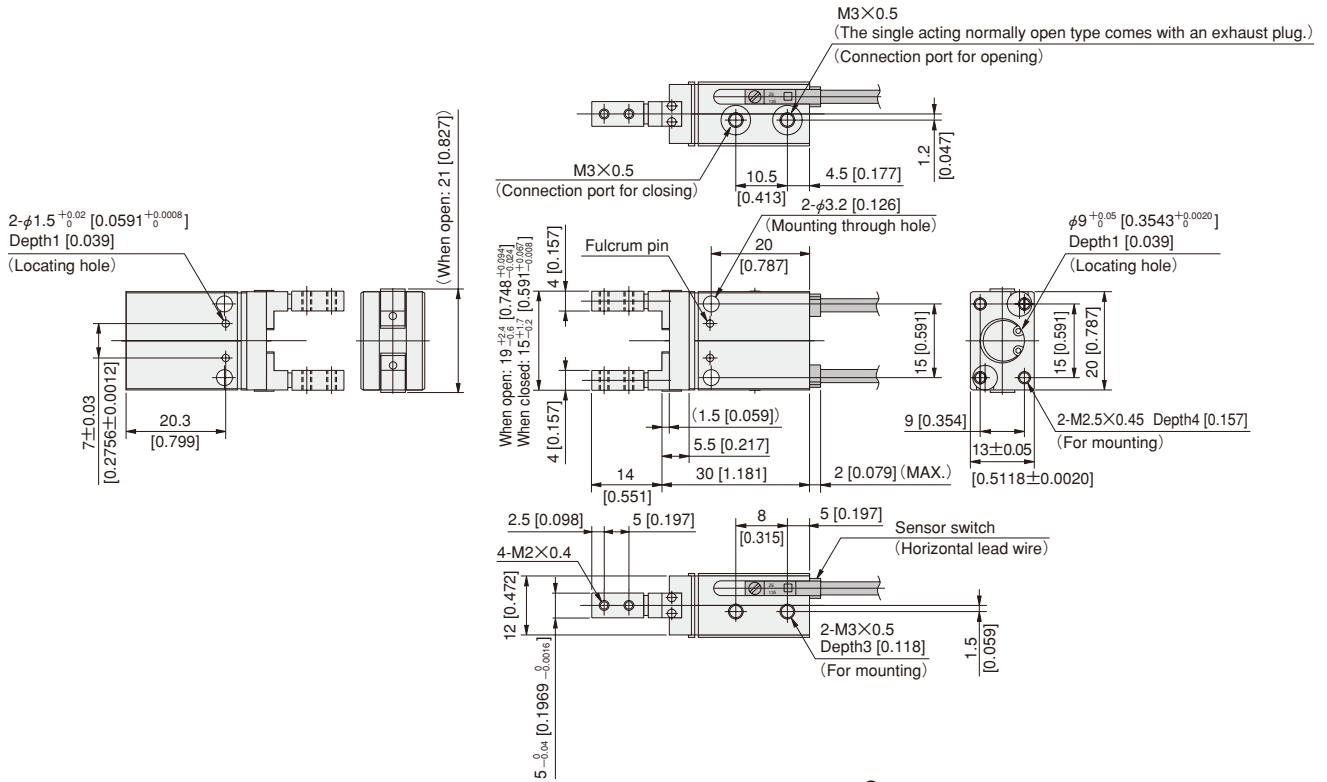

● The sensor switch is optional.
When mounting the sensor switch, always be sure to see the cautions for mounting on p.1460.

Options

● Mounting bracket: -M

NHB-M8

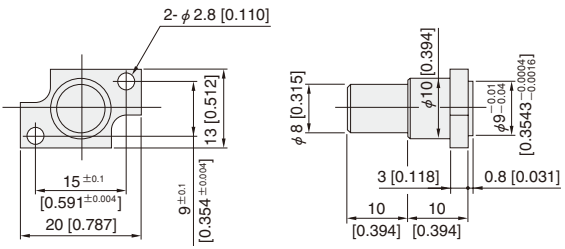

NHB-M10~20

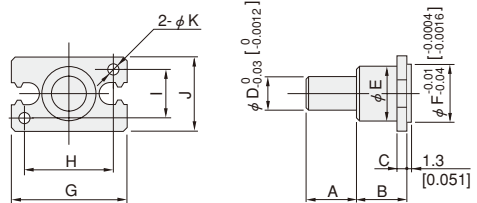

Model	Code	A	B	C	D	E	F	G	H	I	J	K
NHB-M10	15	15	3	10	11	11	23	17	10	16	3.4	
	[0.591]	[0.591]	[0.118]	[0.3937]	[0.433]	[0.4331]	[0.906]	[0.669]	[0.394]	[0.630]	[0.134]	
NHB-M16	15	15	3	10	16	17	34	26	14	22	4.5	
	[0.591]	[0.591]	[0.118]	[0.3937]	[0.630]	[0.6693]	[1.339]	[1.024]	[0.551]	[0.866]	[0.177]	
NHB-M20	15	15	3	10	18	21	45	35	16	26	5.5	
	[0.591]	[0.591]	[0.118]	[0.3937]	[0.709]	[0.8268]	[1.772]	[1.378]	[0.630]	[1.024]	[0.217]	

Dimensions of Linear Guide Specification with Fingers mm [in.]

NHB □ PGY-10
 NHB □ PGY-16
 NHB □ PGY-20



※ Drawings show $\phi 16$ [0.630in.].

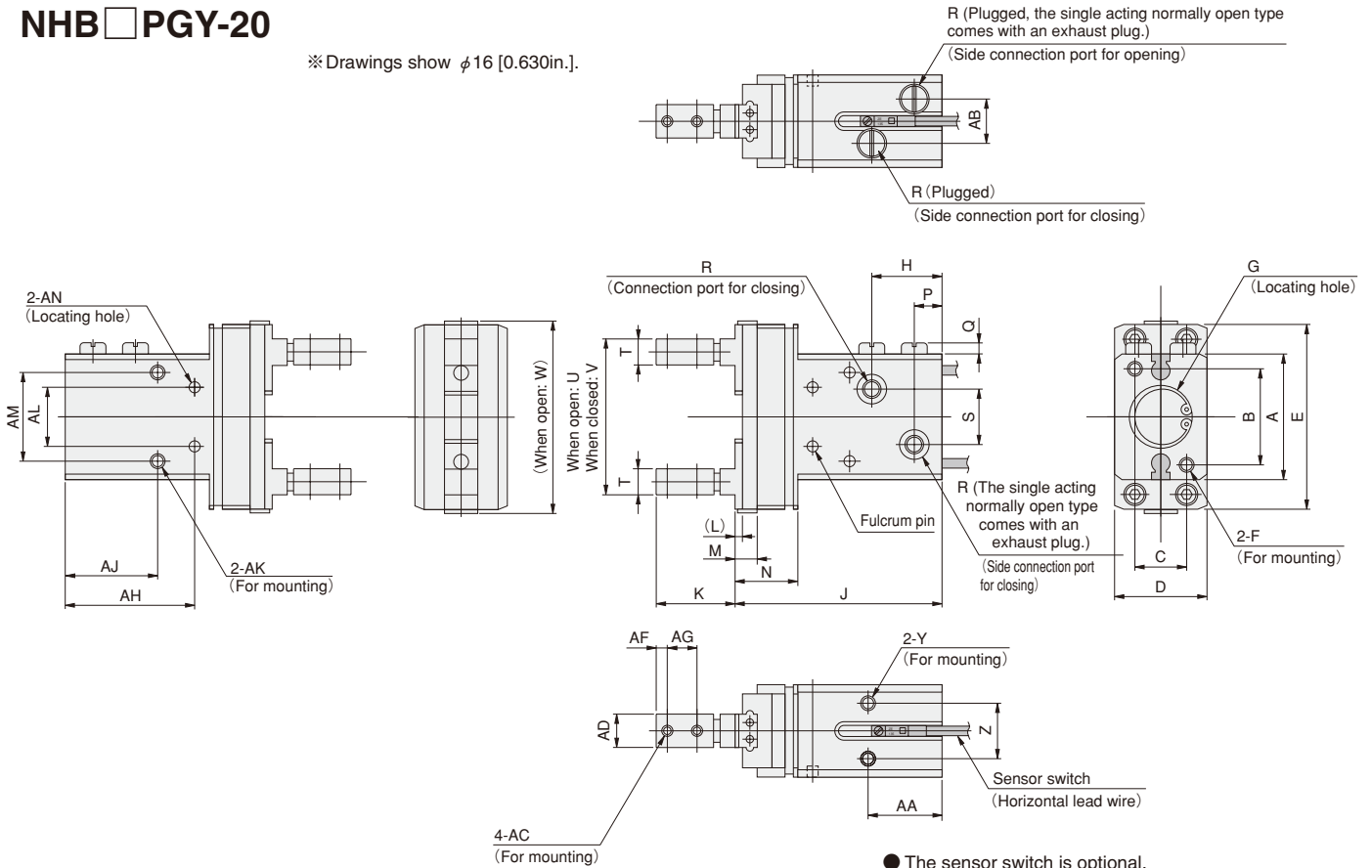

● The sensor switch is optional.
 When mounting the sensor switch, always be sure to see the cautions for mounting on p.1460.

Model	Code	A	B	C	D	E	F	G	H	J	K	L
NHB □ PGY-10		23 [0.906]	17 [0.669]	10 [0.394]	20±0.05 [0.7874 ±0.0020]	36 [1.417]	M3×0.5 Depth6 [0.236]	$\phi 11^{+0.05}_0$ [0.4331 ^{+0.0020}] Depth1.5 [0.059]	17 [0.669]	49 [1.929]	18.5 [0.728]	1.5 [0.059]
NHB □ PGY-16		34 [1.339]	26 [1.024]	14 [0.551]	25±0.05 [0.9843 ±0.0020]	50 [1.969]	M4×0.7 Depth7 [0.276]	$\phi 17^{+0.05}_0$ [0.6693 ^{+0.0020}] Depth1.5 [0.059]	19 [0.748]	56 [2.205]	21 [0.827]	2 [0.079]
NHB □ PGY-20		45 [1.772]	35 [1.378]	16 [0.630]	32±0.05 [1.2598 ±0.0020]	62 [2.441]	M5×0.8 Depth9 [0.354]	$\phi 21^{+0.05}_0$ [0.8268 ^{+0.0020}] Depth1.5 [0.059]	21 [0.827]	67 [2.638]	30 [1.181]	3 [1.181]

M	N	P	Q	R	S	T	U	V	W	Y	Z	AA	AB
6 [0.236]	14 [0.551]	7.5 [0.295]	2.5 [0.098]	M3×0.5	7 [0.276]	5 [0.197]	30 ^{+2.2} _{-0.2} [1.181 +0.087 -0.008]	23.5 ^{+1.7} _{-0.2} [0.925 +0.067 -0.008]	37 [1.457]	M3×0.5 Depth5 [0.197]	12 [0.472]	20 [0.787]	9 [0.354]
8 [0.315]	17 [0.669]	7.5 [0.295]	3 [0.118]	M5×0.8	15 [0.591]	7 [0.276]	41 ^{+2.9} _{-0.6} [1.614 +0.114 -0.024]	31 ^{+1.8} _{-0.5} [1.220 +0.071 -0.020]	52 [2.047]	M4×0.7 Depth6 [0.236]	15 [0.591]	20 [0.787]	12 [0.472]
10 [0.394]	23 [0.906]	7.5 [0.295]	3 [0.118]	M5×0.8	17 [0.669]	8±0.1 [0.315 ±0.004]	52 ^{+3.5} _{-0.5} [2.047 +0.138 -0.020]	38 ^{+2.4} _{-0.8} [1.496 +0.094 -0.031]	64 [2.520]	M5×0.8 Depth8 [0.315]	18 [0.709]	24 [0.945]	16 [0.630]

AC	AD	AE	AF	AG	AH	AJ	AK	AL	AM	AN
M3×0.5	7 ^{-0.04} ₀ [0.2756 -0.0016]	17 [0.669]	3 [0.118]	6 [0.236]	33 [1.299]	25 [0.984]	M4×0.7 Depth6 [0.236], Drilled hole diameter $\phi 3.4$ [0.134] through hole	12±0.03 [0.4724 ±0.0012]	17 [0.669]	$\phi 2.5^{+0.02}_0$ [0.0984 ^{+0.0008}] Depth2.5 [0.098]
M3×0.5	9 ^{-0.04} ₀ [0.3543 -0.0016]	20 [0.787]	3 [0.118]	8 [0.315]	35 [1.378]	25 [0.984]	M4×0.7 Depth6 [0.236], Drilled hole diameter $\phi 3.4$ [0.134] through hole	16±0.03 [0.6299 ±0.0012]	24 [0.945]	$\phi 3^{+0.02}_0$ [0.1181 ^{+0.0008}] Depth3 [0.118]
M4×0.7	12 ^{-0.05} ₀ [0.4724 -0.0020]	27 [1.063]	4 [0.157]	10 [0.394]	39.7 [1.563]	30 [1.181]	M5×0.8 Depth8 [0.315], Drilled hole diameter $\phi 4.2$ [0.165] through hole	22±0.03 [0.8661 ±0.0012]	30 [1.181]	$\phi 4^{+0.02}_0$ [0.1575 ^{+0.0008}] Depth3.5 [0.138]

AIR HANDS SERIES

NHB SERIES PARALLEL TYPE

Linear Guide Specification with Rubber Cover
Double Acting Type, Single Acting Normally Open Type

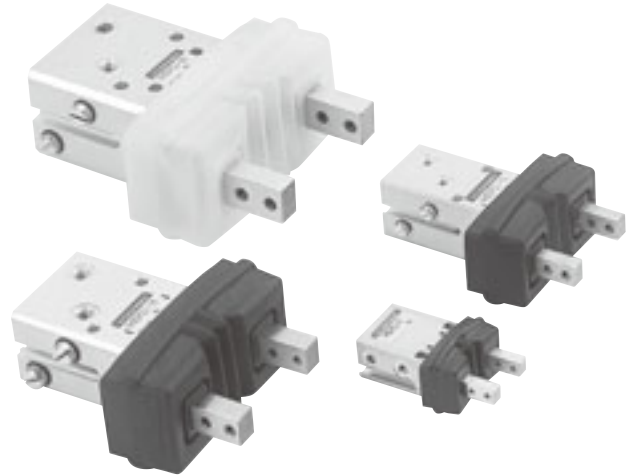

Symbols

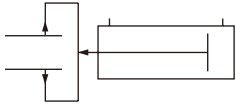

Double Acting Type

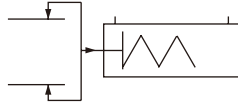

Single Acting
Normally Open Type

Specifications

● Double acting parallel type (with rubber cover)

Basic model		NHBDPGJ-8	NHBDPGJ-10	NHBDPGJ-16	NHBDPGJ-20
Item					
Cylinder bore size	mm [in.]	8 [0.315]	10 [0.394]	16 [0.630]	20 [0.787]
Operation type		Double acting type			
Media		Air			
Operating pressure range	MPa [psi.]	0.3~0.7 [44~102]	0.25~0.7 [36~102]	0.15~0.7 [22~102]	
Proof pressure	MPa [psi.]	1.05 [152]			
Operating temperature range	°C [°F]	0~60 [32~140]			
Maximum operating frequency	cycle/min	100			
Lubrication		Not required			
Effective gripping force (F) ^{Note 1}	Closed side	5.8 [1.30]	9.4 [2.11]	26.4 [5.93]	45.0 [10.12]
	Open side	9.9 [2.23]	14.7 [3.30]	39.2 [8.81]	59.8 [13.44]
Lever open/closed stroke	mm [in.]	4 [0.157]	6.5 [0.256]	10 [0.394]	14 [0.551]
Repeatability	mm [in.]	±0.01 [±0.0004]			
Port size		M3×0.5		M5×0.8	
Mass ^{Note 2}	g [oz.]	27 [0.95] (32 [1.13])	90 [3.17] (101 [3.56])	180 [6.35] (119 [4.20])	370 [13.05] (396 [13.97])

Notes: 1. Values are obtained when grip point length is 30mm [1.18in.] under operating pressure 0.5 MPa [73psi.]. For details of the effective gripping force, see the graphs on p.1385.

2. () mean the mass with the mounting bracket: -M.

Remark: The life of rubber cover may vary from the air hand (gripper), depending on its operating conditions.

● Single acting normally open parallel type (with rubber cover)

Basic model		NHBRPGJ-8	NHBRPGJ-10	NHBRPGJ-16	NHBRPGJ-20
Item					
Cylinder bore size	mm [in.]	8 [0.315]	10 [0.394]	16 [0.630]	20 [0.787]
Operation type		Normally open single acting type			
Media		Air			
Operating pressure range	MPa [psi.]	0.5~0.7 [73~102]	0.4~0.7 [58~102]	0.3~0.7 [44~102]	
Proof pressure	MPa [psi.]	1.05 [152]			
Operating temperature range	°C [°F]	0~60 [32~140]			
Maximum operating frequency	cycle/min	100			
Lubrication		Not required			
Effective gripping force (F) ^{Note 1}	Closed side	4.1 [0.92]	6.8 [1.53]	19.6 [4.41]	34.3 [7.71]
	Open side	2.7 [0.61]	2.4 [0.54]	5.4 [1.21]	7.3 [1.64]
Lever open/closed stroke	mm [in.]	4 [0.157]	6.5 [0.256]	10 [0.394]	14 [0.551]
Repeatability	mm [in.]	±0.01 [±0.0004]			
Port size		M3×0.5		M5×0.8	
Mass ^{Note 2}	g [oz.]	28 [0.99] (33 [1.16])	91 [3.21] (102 [3.60])	181 [6.38] (200 [7.05])	371 [13.09] (397 [14.00])

Notes: 1. Values are obtained when grip point length is 30mm [1.18in.] under operating pressure 0.5 MPa [73psi.]. For details of the effective gripping force, see the graphs on p.1385.

2. () mean the mass with the mounting bracket: -M.

Remark: The life of rubber cover may vary from the air hand (gripper), depending on its operating conditions.

Inner Construction

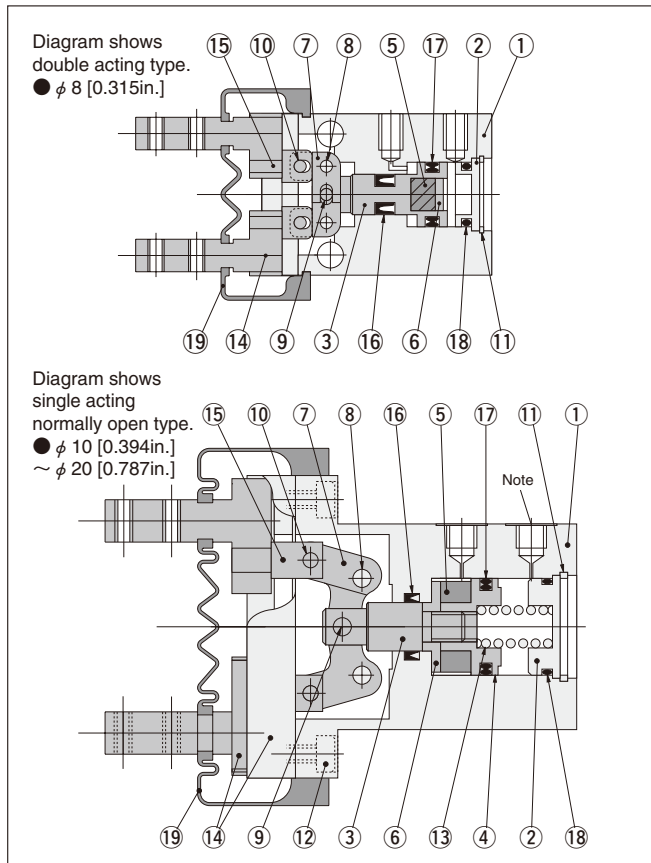

Note: An exhaust plug is attached to the exhaust connection port of the single acting normally open type. Plugs are attached to the extra connection ports on the side surface (except ϕ 8 [0.315in.]).

Major Parts and Materials

No.	Parts	Materials	Remarks
①	Body	Aluminum alloy	
②	Head cover	Aluminum alloy	
③	Piston rod	Stainless steel	
④	Piston	Aluminum alloy	Except ϕ 8 [0.315in.].
⑤	Magnet	Plastic magnet	
⑥	Magnet holder	Aluminum alloy	
⑦	Action lever	Steel	
⑧	Fulcrum pin	Steel	
⑨	Press fit pin	Steel	
⑩	Press fit pin	Steel	
⑪	Internal snap ring	Steel	
⑫	Hexagon socket head bolt	Steel	
⑬	Spring	Steel wire	Single acting type only
⑭	Bearing	Stainless steel	
⑮	Knuckle	Stainless steel	
⑯	Seal	Synthetic rubber (NBR)	
⑰	Seal	Synthetic rubber (NBR)	
⑱	O-ring	Synthetic rubber (NBR)	
⑲	Rubber cover	Synthetic rubber ^{Note}	

Note: -JN: NBR, -JF: Fluoro rubber, -JS: Silicone rubber.

Order Codes

	Rubber cover material	Mounting bracket	Sensor switch	Lead wire length	Number of sensor switches		
	<ul style="list-style-type: none"> ● -JN: NBR (Black with blue mark) ● -JF: Fluoro rubber (Black with green mark) ● -JS: Silicone rubber (White) 	No mounting bracket Blank With mounting bracket -M ★ Included at shipping	No sensor switch Blank With ZE135 -ZE135 With ZE155 -ZE155 With ZE235 -ZE235 With ZE255 -ZE255 <ul style="list-style-type: none"> ● Solid state type ● With indicator lamp ● DC10~28V ● 2-lead wire ● Horizontal lead wire 	A : 1000mm [39in.] B : 3000mm [118in.]	(for air hands with sensor switches) ● 1 : With 1 sensor switch ● 2 : With 2 sensor switches ★ Included at shipping		
	Basic model	Cylinder bore size					
Double acting type	NHBDPGJ	-8 -10 -16 -20	-JN -JF -JS	-M	-ZE135 -ZE155 -ZE235 -ZE255	A B	1 2
Single acting normally open type	NHBRPGJ	-8 -10 -16 -20	-JN -JF -JS	-M	-ZE135 -ZE155 -ZE235 -ZE255	A B	1 2

Additional Parts (To be ordered separately)

Mounting bracket

- For ϕ 8 [0.315in.]—NHB-M8
- For ϕ 10 [0.394in.]—NHB-M10
- For ϕ 16 [0.630in.]—NHB-M16
- For ϕ 20 [0.787in.]—NHB-M20

Rubber cover

-NHBDPGJ

Rubber cover material Bore size

- JN: NBR 8 : ϕ 8 [0.315in.] (Black with blue mark)
- JF: Fluoro rubber (Black with green mark)
- JS: Silicone rubber (White)
- 10 : ϕ 10 [0.394in.]
- 16 : ϕ 16 [0.630in.]
- 20 : ϕ 20 [0.787in.]

Dimensions of Linear Guide Specification Parallel Type with Rubber Cover (mm)

NHB □ PGJ-8

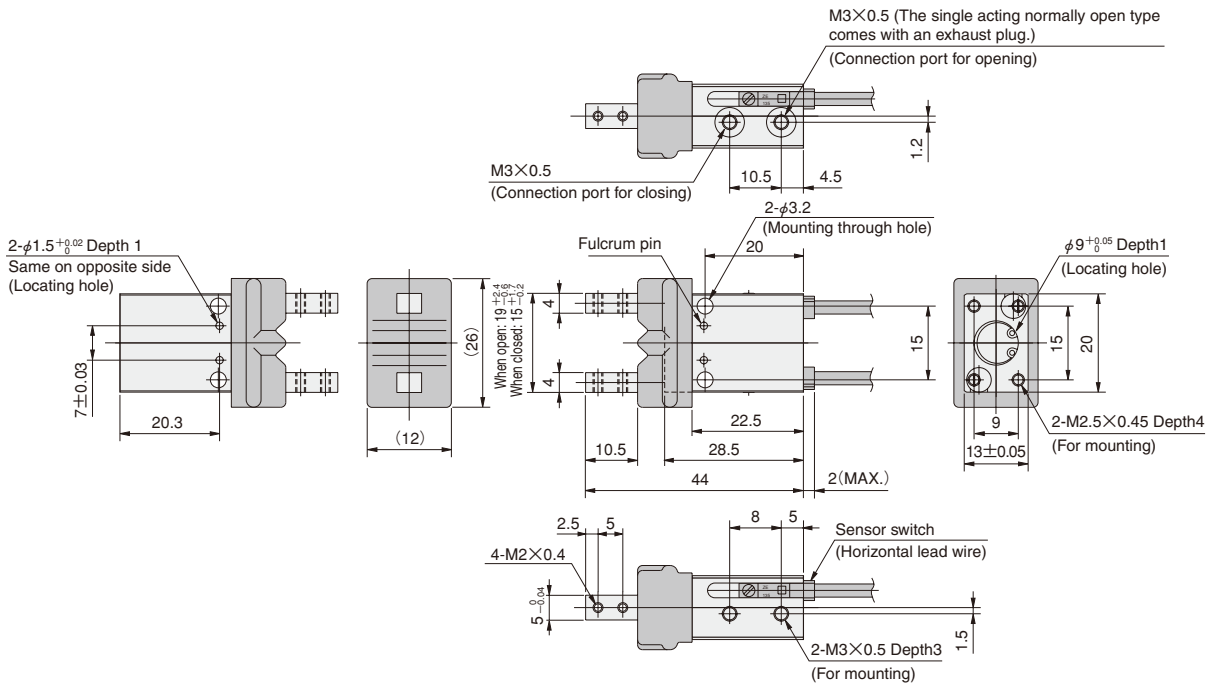

- The sensor switch is optional. When mounting the sensor switch, always be sure to see the cautions for mounting on p.1460.

Options



- Mounting bracket: -M

NHB-M8

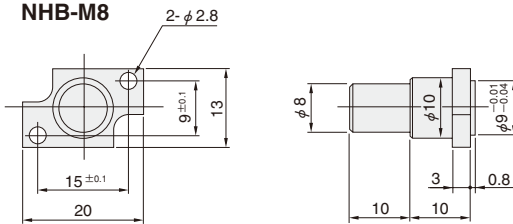

NHB-M10~20

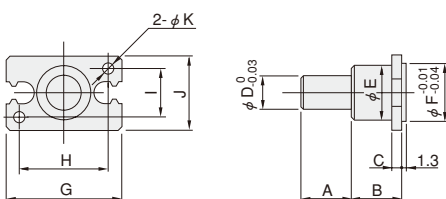

Model	Code	A	B	C	D	E	F	G	H	I	J	K
NHB-M10		15	15	3	10	11	11	23	17	10	16	3.4
NHB-M16		15	15	3	10	16	17	34	26	14	22	4.5
NHB-M20		15	15	3	10	18	21	45	35	16	26	5.5

Dimensions of Linear Guide Specification Parallel Type with Rubber Cover (mm)

NHB □ PGJ-10
 NHB □ PGJ-16
 NHB □ PGJ-20

※ Drawings show $\phi 16$ [0.630in.].

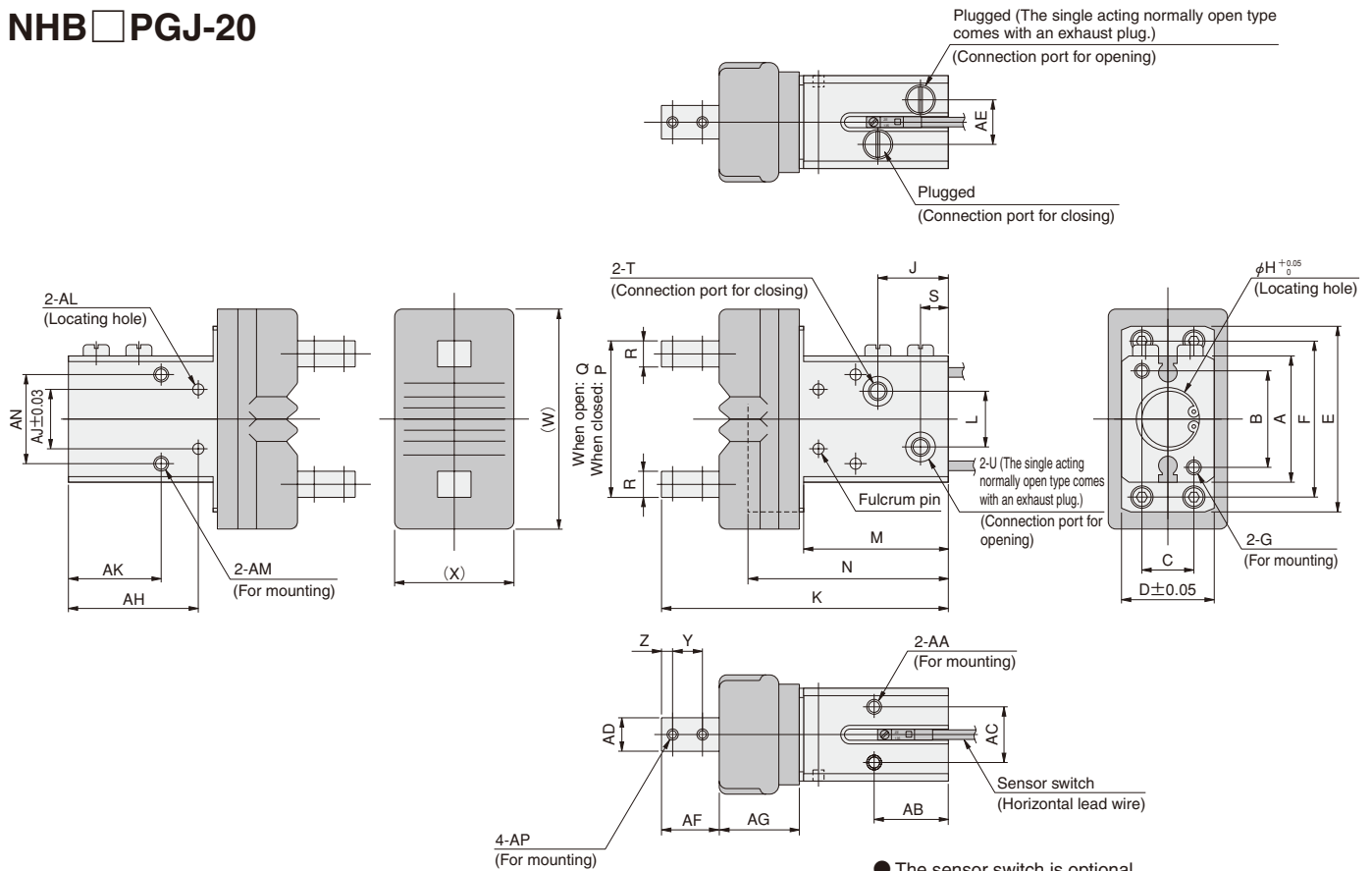

● The sensor switch is optional.
 When mounting the sensor switch, always be sure to see the cautions for mounting on p.1460.

Model	Code	A	B	C	D	E	F	G	H	J	K	L	M
NHB □ PGJ-10		23	17	10	20	36	30	M3×0.5 Depth 6	11 Depth 1.5	17	67.5	7	35
NHB □ PGJ-16		34	26	14	25	50	42	M4×0.7 Depth 7	17 Depth 1.5	19	77	15	39
NHB □ PGJ-20		45	35	16	32	62	54	M5×0.8 Depth 9	21 Depth 1.5	21	97	17	44

N	P	Q	R	S	T	U	W	X	Y	Z	AA	AB	AC
47.5	23.5 $\begin{smallmatrix} +1.7 \\ -0.2 \end{smallmatrix}$	30 $\begin{smallmatrix} +2.2 \\ -0.2 \end{smallmatrix}$	5	7.5	M3×0.5	M3×0.5	44	27	6	3	M3×0.5 Depth 5	20	12
54	31 $\begin{smallmatrix} +1.8 \\ -0.5 \end{smallmatrix}$	41 $\begin{smallmatrix} +2.9 \\ -0.6 \end{smallmatrix}$	7	7.5	M5×0.8	M5×0.8	59	32	8	3	M4×0.7 Depth 6	20	15
64	38 $\begin{smallmatrix} +2.4 \\ -0.8 \end{smallmatrix}$	52 $\begin{smallmatrix} +3.5 \\ -0.5 \end{smallmatrix}$	8	7.5	M5×0.8	M5×0.8	71	42	10	4	M5×0.8 Depth 8	24	18

AD	AE	AF	AG	AH	AJ	AK	AL	AM	AN	AP
7 $\begin{smallmatrix} 0 \\ -0.04 \end{smallmatrix}$	9	13	18.5	33	12	25	$\phi 2.5^{+0.02}_0$ Depth 2.5	M4×0.7 Depth 6, Drilled hole diameter $\phi 3.4$ thru hole	17	M3×0.5
9 $\begin{smallmatrix} 0 \\ -0.04 \end{smallmatrix}$	12	15.5	21.5	35	16	25	$\phi 3^{+0.02}_0$ Depth 3	M4×0.7 Depth 6, Drilled hole diameter $\phi 3.4$ thru hole	24	M3×0.5
12 $\begin{smallmatrix} 0 \\ -0.05 \end{smallmatrix}$	16	20	28.5	39.7	22	30	$\phi 4^{+0.02}_0$ Depth 3.5	M4×0.8 Depth 8, Drilled hole diameter $\phi 4.2$ thru hole	30	M4×0.7

NHB SERIES PARALLEL TYPE

Linear Guide Specification
for Clean Systems
Double Acting Type



Symbol

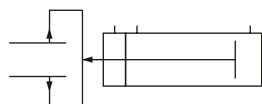

Specifications

Basic model		CS-NHBDPG-8	CS-NHBDPG-10	CS-NHBDPG-16	CS-NHBDPG-20
Cylinder bore size	mm [in.]	8 [0.315]	10 [0.394]	16 [0.630]	20 [0.787]
Operation type		Double acting type			
Media		Air			
Operating pressure range	MPa [psi.]	0.22~0.7 [32~102]	0.2~0.7 [29~102]	0.12~0.7 [17~102]	0.1~0.7 [15~102]
Proof pressure	MPa [psi.]	1.05 [152]			
Operating temperature range	°C [°F]	0~60 [32~140]			
Maximum operating frequency	cycle/min	120			
Lubrication		Not required			
Effective gripping force (F) ^{Note 1}	Closed side	5.8 [1.30]	9.4 [2.11]	26.4 [5.93]	45.0 [10.12]
	Open side	9.9 [2.23]	14.7 [3.30]	39.2 [8.81]	59.8 [13.44]
Lever open/closed stroke	mm [in.]	4 [0.157]	6.5 [0.256]	10 [0.394]	14 [0.551]
Repeatability	mm [in.]	±0.01 [±0.0004]			
Port size		M3×0.5		M5×0.8	
Mass ^{Note 2}	g [oz.]	24 [0.85] (29 [1.02])	80 [2.82] (91 [3.21])	159 [5.61] (178 [6.28])	329 [11.60] (355 [12.52])

Notes: 1. Values are obtained when grip point length is 30mm [1.18in.] under operating pressure 0.5 MPa [73psi.]. For details of the effective gripping force, see the graphs on p.1385.

2. () mean the mass with the mounting bracket: -M.

Inner Construction

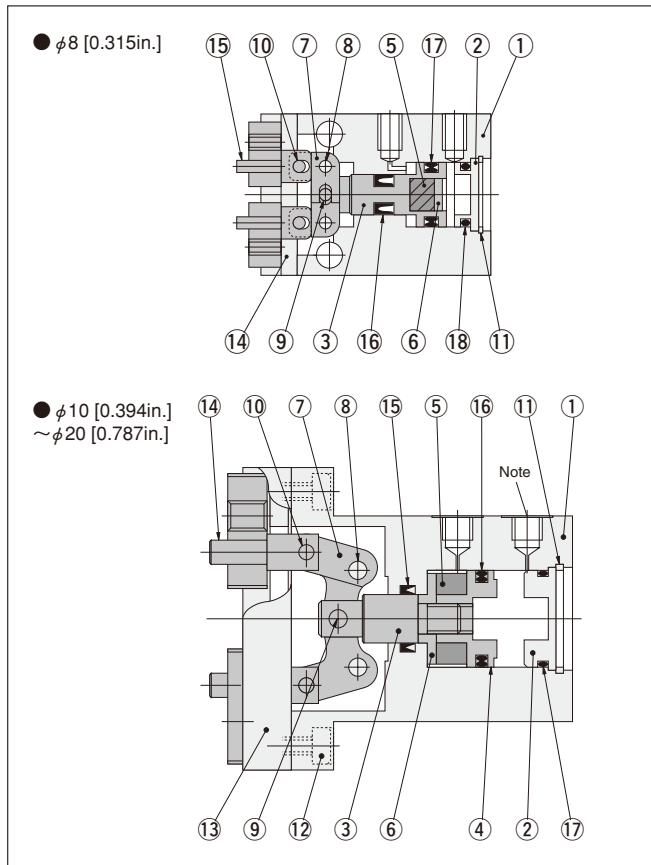

Note: Plugs are attached to the extra connection ports on the side surface (except φ 8 [0.135in.]).

Major Parts and Materials

No.	Parts	Materials	Remarks
①	Body	Aluminum alloy	
②	Head cover	Aluminum alloy	
③	Piston rod	Stainless steel	
④	Piston	Aluminum alloy	Except φ 8 [0.315in.].
⑤	Magnet	Plastic magnet	
⑥	Magnet holder	Aluminum alloy	
⑦	Action lever	Steel	
⑧	Fulcrum pin	Steel	
⑨	Press fit pin	Steel	
⑩	Press fit pin	Steel	
⑪	Internal snap ring	Steel	
⑫	Hexagon socket head bolt	Steel	
⑬	Bearing	Stainless steel	
⑭	Knuckle	Stainless steel	
⑮	Seal	Synthetic rubber (NBR)	
⑯	Seal	Synthetic rubber (NBR)	
⑰	O-ring	Synthetic rubber (NBR)	

Order Codes

Air Hands for Clean Systems	Mounting bracket	Sensor switch	Lead wire length	Number of sensor switches (for air hands with sensor switches)		
<ul style="list-style-type: none"> No mounting bracket Blank With mounting bracket -M ★ Included at shipping 	<ul style="list-style-type: none"> No sensor switch Blank With ZE135 -ZE135 With ZE155 -ZE155 With ZE235 -ZE235 With ZE255 -ZE255 	<ul style="list-style-type: none"> Solid state type With indicator lamp DC10~28V 2-lead wire Horizontal lead wire Solid state type With indicator lamp DC4.5~28V 3-lead wire Horizontal lead wire Solid state type With indicator lamp DC10~28V 2-lead wire Vertical lead wire Solid state type With indicator lamp DC4.5~28V 3-lead wire Vertical lead wire 	<ul style="list-style-type: none"> A : 1000mm [39in.] B : 3000mm [118in.] 	<ul style="list-style-type: none"> ● 1 : With 1 sensor switch ● 2 : With 2 sensor switches ★ Included at shipping 		
<ul style="list-style-type: none"> Basic model CS 	<ul style="list-style-type: none"> Cylinder bore size -NHBDPG 	<ul style="list-style-type: none"> -8 -10 -16 -20 	<ul style="list-style-type: none"> -M 	<ul style="list-style-type: none"> -ZE135 -ZE155 -ZE235 -ZE255 	<ul style="list-style-type: none"> A B 	<ul style="list-style-type: none"> 1 2

Additional Parts (To be ordered separately)

Mounting bracket

- For φ 8 [0.315in.] —NHB-M8
- For φ 10 [0.394in.] —NHB-M10
- For φ 16 [0.630in.] —NHB-M16
- For φ 20 [0.787in.] —NHB-M20

CS-NHBDPG-8

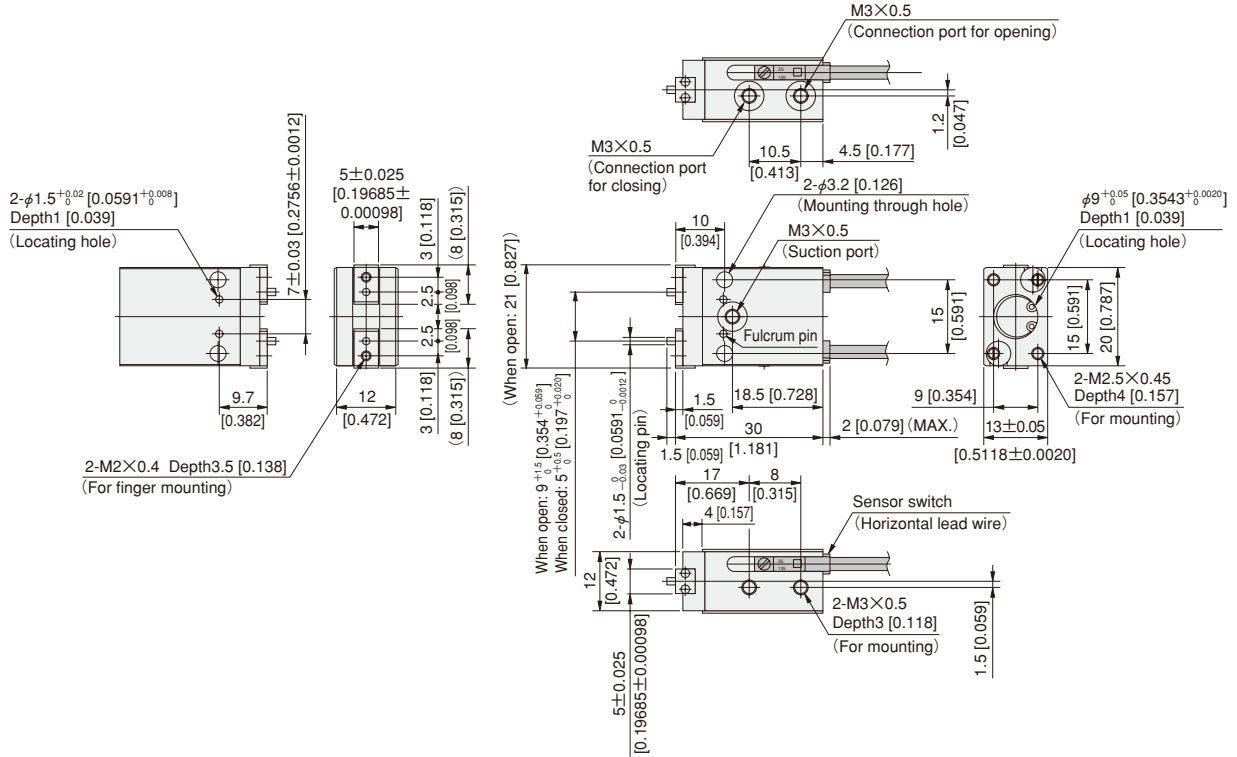

● The sensor switch is optional.
When mounting the sensor switch, always be sure to see the cautions for mounting on p.1460.

Options

● Mounting bracket: -M

NHB-M8

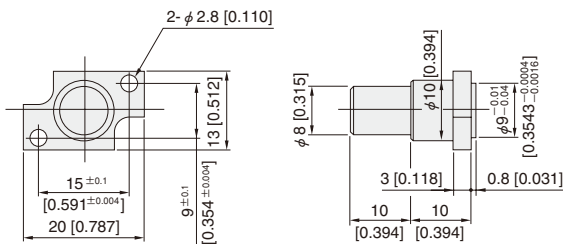

NHB-M10~20

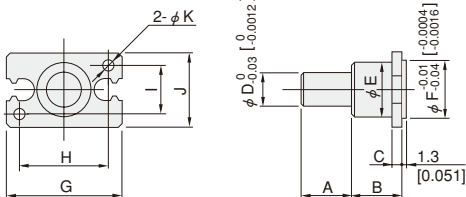

Model	Code	A	B	C	D	E	F	G	H	I	J	K
NHB-M10	15	15	3	10	11	11	23	17	10	16	3.4	
		[0.591]	[0.591]	[0.118]	[0.3937]	[0.433]	[0.4331]	[0.906]	[0.669]	[0.394]	[0.630]	[0.134]
NHB-M16	15	15	3	10	16	17	34	26	14	22	4.5	
		[0.591]	[0.591]	[0.118]	[0.3937]	[0.630]	[0.6693]	[1.339]	[1.024]	[0.551]	[0.866]	[0.177]
NHB-M20	15	15	3	10	18	21	45	35	16	26	5.5	
		[0.591]	[0.591]	[0.118]	[0.3937]	[0.709]	[0.8268]	[1.772]	[1.378]	[0.630]	[1.024]	[0.217]

CS-NHBDPG-10
CS-NHBDPG-16
CS-NHBDPG-20

※ Drawings show $\phi 16$ [0.630in.].

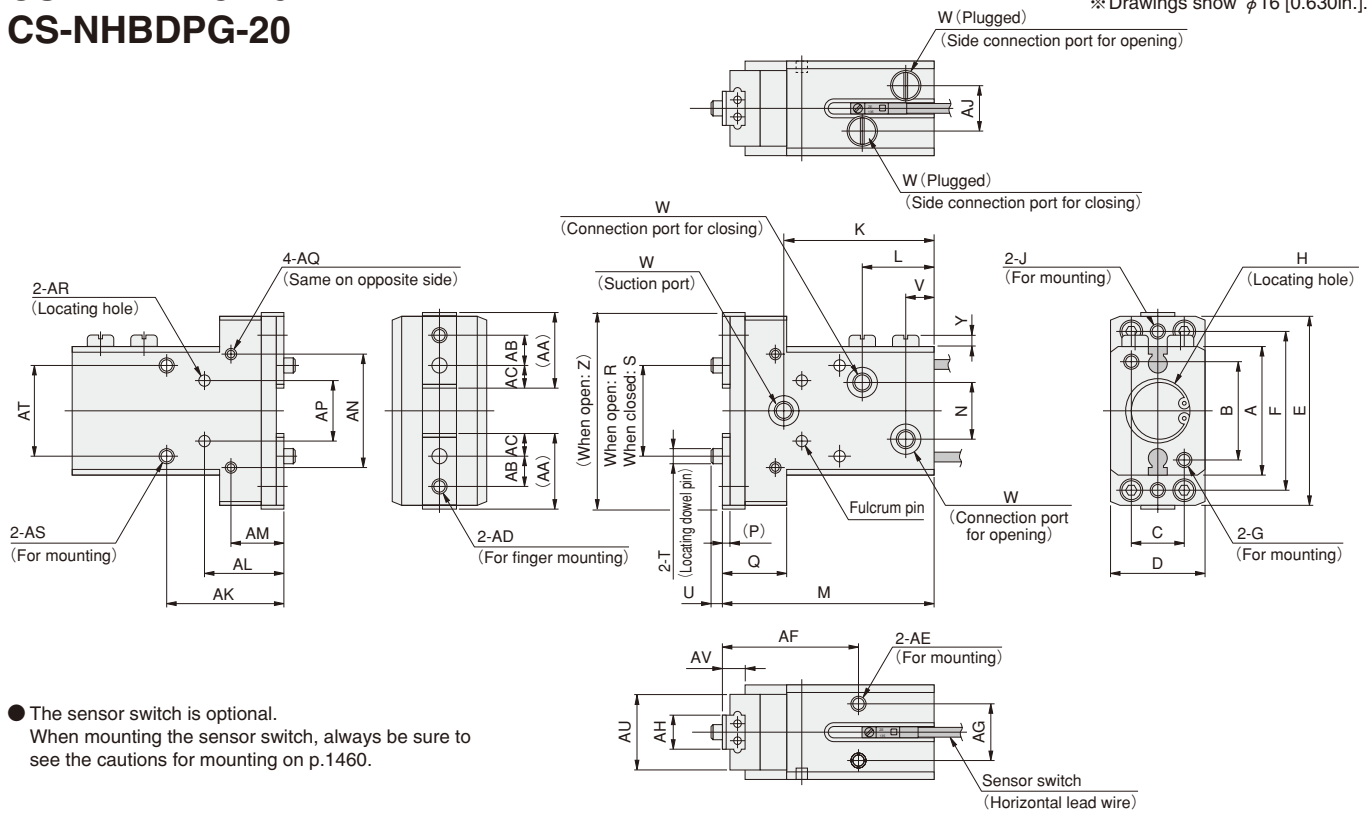

● The sensor switch is optional.
 When mounting the sensor switch, always be sure to see the cautions for mounting on p.1460.

Model	Code	A	B	C	D	E	F	G	H	J	K	L	M	N	P
CS-NHBDPG-10		23 [0.906]	17 [0.669]	10 [0.394]	20±0.05 [0.7874 ±0.0020]	36 [1.417]	30 [1.181]	M3×0.5 Depth6 [0.236]	$\phi 11^{+0.05}_0$ [0.4331 ^{+0.0020} Depth1.5 [0.059]	M3×0.5 Depth4.5 [0.177]	35 [1.378]	17 [0.669]	49 [1.929]	7 [0.276]	1.5 [0.059]
CS-NHBDPG-16		34 [1.339]	26 [1.024]	14 [0.551]	25±0.05 [0.9843 ±0.0020]	50 [1.969]	42 [1.654]	M4×0.7 Depth7 [0.276]	$\phi 17^{+0.05}_0$ [0.6693 ^{+0.0020} Depth1.5 [0.059]	M4×0.7 Depth5 [0.197]	40 [1.575]	19 [0.748]	56 [2.205]	15 [0.591]	2 [0.079]
CS-NHBDPG-20		45 [1.772]	35 [1.378]	16 [0.630]	32±0.05 [1.2598 ±0.0020]	62 [2.441]	54 [2.126]	M5×0.8 Depth9 [0.354]	$\phi 21^{+0.05}_0$ [0.8268 ^{+0.0020} Depth1.5 [0.059]	M4×0.7 Depth7 [0.276]	45 [1.772]	21 [0.827]	67 [2.638]	17 [0.669]	3 [1.181]

Q	R	S	T	U	V	W	Y	Z	AA	AB	AC	AD	AE	AF	AG
14 [0.551]	15.5 ^{+0.08} ₀ [0.610 +0.031]	9 ^{+0.5} ₀ [0.354 +0.020]	$\phi 3_{-0.03}^0$ [0.1181 -0.0012]	2 [0.079]	7.5 [0.295]	M3×0.5	2 [0.079]	37 [1.457]	14.7 [0.579]	5 [0.197]	4.5 [0.177]	M3×0.5 Depth4 [0.157]	M3×0.5 Depth5 [0.197]	29 [1.142]	12 [0.472]
17 [0.669]	22 ^{+1.8} ₀ [0.866 +0.071]	12 ^{+1.3} ₀ [0.472 +0.051]	$\phi 4_{-0.03}^0$ [0.1575 -0.0012]	3 [0.118]	7.5 [0.295]	M5×0.8	3 [0.118]	52 [2.047]	20 [0.787]	8 [0.315]	6 [0.236]	M4×0.7 Depth5 [0.197]	M4×0.7 Depth6 [0.236]	36 [1.417]	15 [0.591]
23 [0.906]	30 ^{+2.9} ₀ [1.181 +0.114]	16 ^{+1.4} ₀ [0.630 +0.055]	$\phi 5_{-0.03}^0$ [0.1969 -0.0012]	3 [0.118]	7.5 [0.295]	M5×0.8	3 [0.118]	64 [2.520]	24 [0.945]	8 [0.315]	8 [0.315]	M5×0.8 Depth7 [0.276]	M5×0.8 Depth8 [0.315]	43 [1.693]	18 [0.709]

AH	AJ	AK	AL	AM	AN	AP	AQ	AR	AS	AT	AU	AV
7±0.025 [0.27559 ±0.00098]	9 [0.354]	24 [0.945]	16 [0.630]	11 [0.433]	20 [0.787]	12±0.03 [0.4724 ±0.0012]	M3×0.5 Depth5 [0.197]	$\phi 2.5^{+0.02}_0$ [0.0984 ^{+0.0008} Depth2.5 [0.098]	M4×0.7 Depth6 [0.236], Drilled hole diameter $\phi 3.4$ [0.134] through hole	17 [0.669]	17 [0.669]	6 [0.236]
9±0.025 [0.35433 ±0.00098]	12 [0.472]	31 [1.220]	21 [0.827]	14 [0.551]	30 [1.181]	16±0.03 [0.6299 ±0.0012]	M3×0.5 Depth5 [0.197]	$\phi 3^{+0.02}_0$ [0.1181 ^{+0.0008} Depth3 [0.118]	M4×0.7 Depth7 [0.276], Drilled hole diameter $\phi 3.4$ [0.134] through hole	24 [0.945]	20 [0.787]	8 [0.315]
12±0.025 [0.47244 ±0.00098]	16 [0.630]	37 [1.457]	27.3 [1.075]	17 [0.669]	40 [1.575]	22±0.03 [0.8661 ±0.0012]	M4×0.7 Depth6 [0.236]	$\phi 4^{+0.02}_0$ [0.1575 ^{+0.0008} Depth3.5 [0.138]	M5×0.8 Depth8 [0.315], Drilled hole diameter $\phi 4.2$ [0.165] through hole	30 [1.181]	27 [1.063]	10 [0.394]

AIR HANDS SERIES

THREE-FINGER TYPE LINEAR GUIDE SPECIFICATION

Air Hands

Symbol

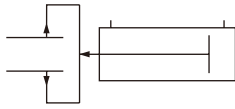

Specifications

Basic model		NHE1D-16	NHE1D-20	NHE1D-25
Item				
Cylinder bore size	mm [in.]	16 [0.630]	20 [0.787]	25 [0.984]
Operation type		Double acting type		
Media		Air		
Operating pressure range	MPa [psi.]	0.25~0.7 [36~102]	0.2~0.7 [29~102]	0.15~0.7 [22~102]
Proof pressure	MPa [psi.]	1.05 [152]		
Operating temperature range	°C [°F]	0~60 [32~140]		
Maximum operating frequency	cycle/min	180		
Lubrication		Not required (However, mechanical sliding portion required)		
Effective gripping force (F) ^{Note 1}	Both open and closed sides N [lbf.]	8 [1.8]	16 [3.6]	29 [6.5]
Lever open/closed stroke	mm [in.]	6 [0.236]	10 [0.394]	14 [0.551]
Repeatability	mm [in.]	±0.01 [±0.0004]		
Centering accuracy	mm [in.]	±0.05 [±0.0020]		
Port size		M5×0.8		
Mass ^{Note 2}	g [oz.]	170 [6.00]	306 [10.79]	580 [20.46]

Note: Values are obtained when grip point length is 30mm [1.18in.] under operating pressure 0.5 MPa [73psi.]. For details of the effective gripping force, see the graphs on p.1386.

Inner Construction

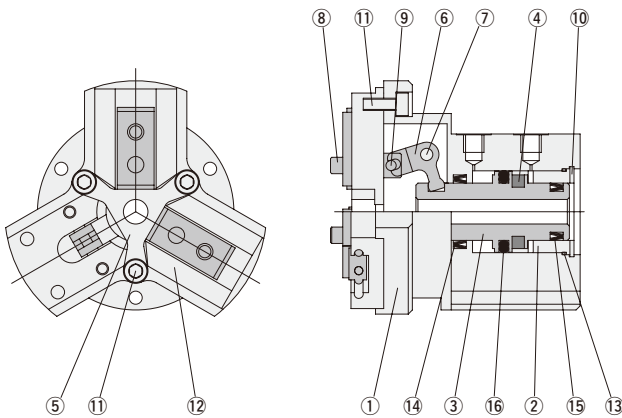

Major Parts and Materials

No.	Parts	Materials
①	Body	Aluminum alloy
②	Head Cover	Aluminum alloy
③	Piston rod	Stainless steel
④	Magnet	Rubber magnet
⑤	Holder cover	Stainless steel
⑥	Action lever	Carbon steel
⑦	Fulcrum pin	Carbon steel
⑧	Knuckle	Stainless steel
⑨	Roller	Carbon steel
⑩	Snap ring	Carbon steel
⑪	Hexagon socket head bolt	Stainless steel
⑫	Bearing	Stainless steel
⑬	O-ring	Synthetic rubber (NBR)
⑭	Seal	Synthetic rubber (NBR)
⑮	Seal	Synthetic rubber (NBR)
⑯	Seal	Synthetic rubber (NBR)

Order Codes

NHE 1 D - [] - [] [] []

Operation type
D : Double acting type

Three-finger hand series
Air hands
High precision specification

Bore size
16 : φ 16mm [0.630in.]
20 : φ 20mm [0.787in.]
25 : φ 25mm [0.984in.]

Sensor switch type

Blank : No sensor switch

ZE135 : 2-lead wire solid state type with indicator Horizontal lead wire DC10~28V
ZE155 : 3-lead wire solid state type with indicator Horizontal lead wire DC4.5~28V
ZE235 : 2-lead wire solid state type with indicator Vertical lead wire DC10~28V
ZE255 : 3-lead wire solid state type with indicator Vertical lead wire DC4.5~28V

● For sensor switch details, see p.1544.

Number of sensor switches

1 : With 1 sensor switch
2 : With 2 sensor switches

Lead wire length

A : 1000mm [39in.]
B : 3000mm [118in.]

Length of Sensor Switch Allowed to Protrude

NHE1D series sensor switch does not protrude.

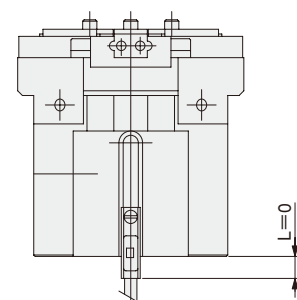

NHE1D-16

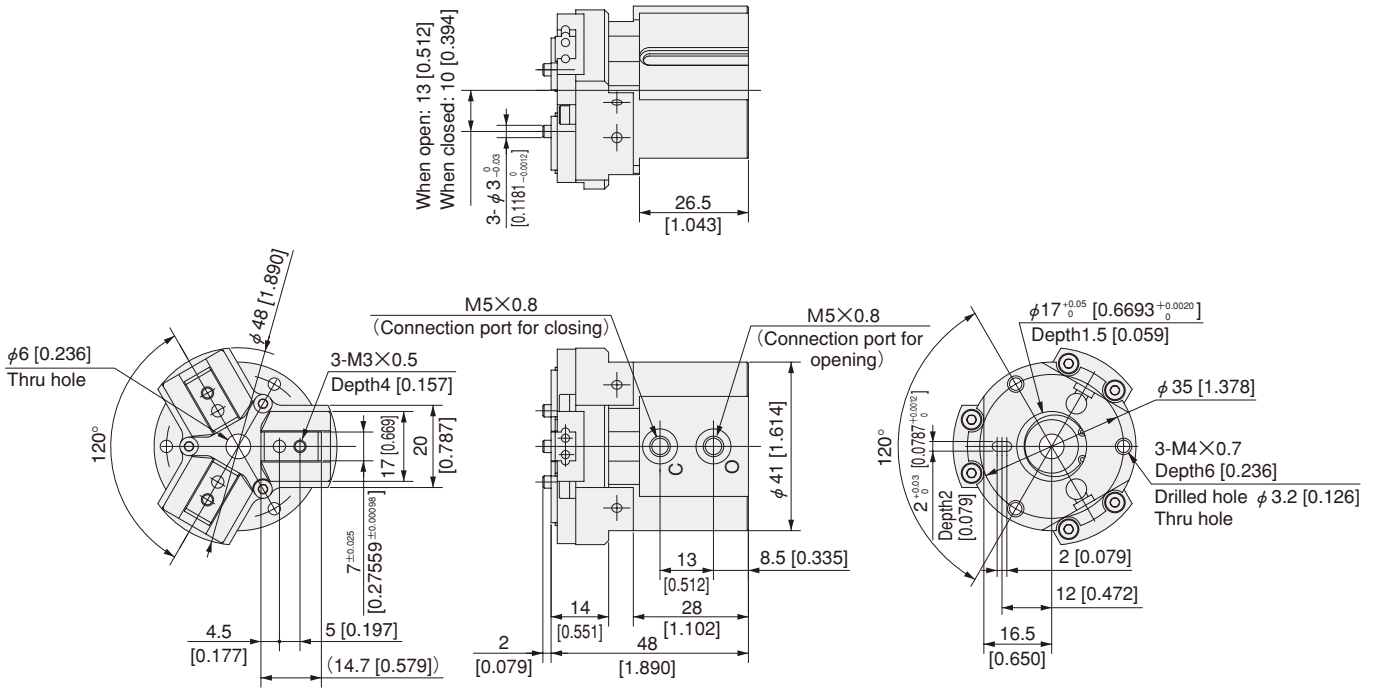

NHE1D-20

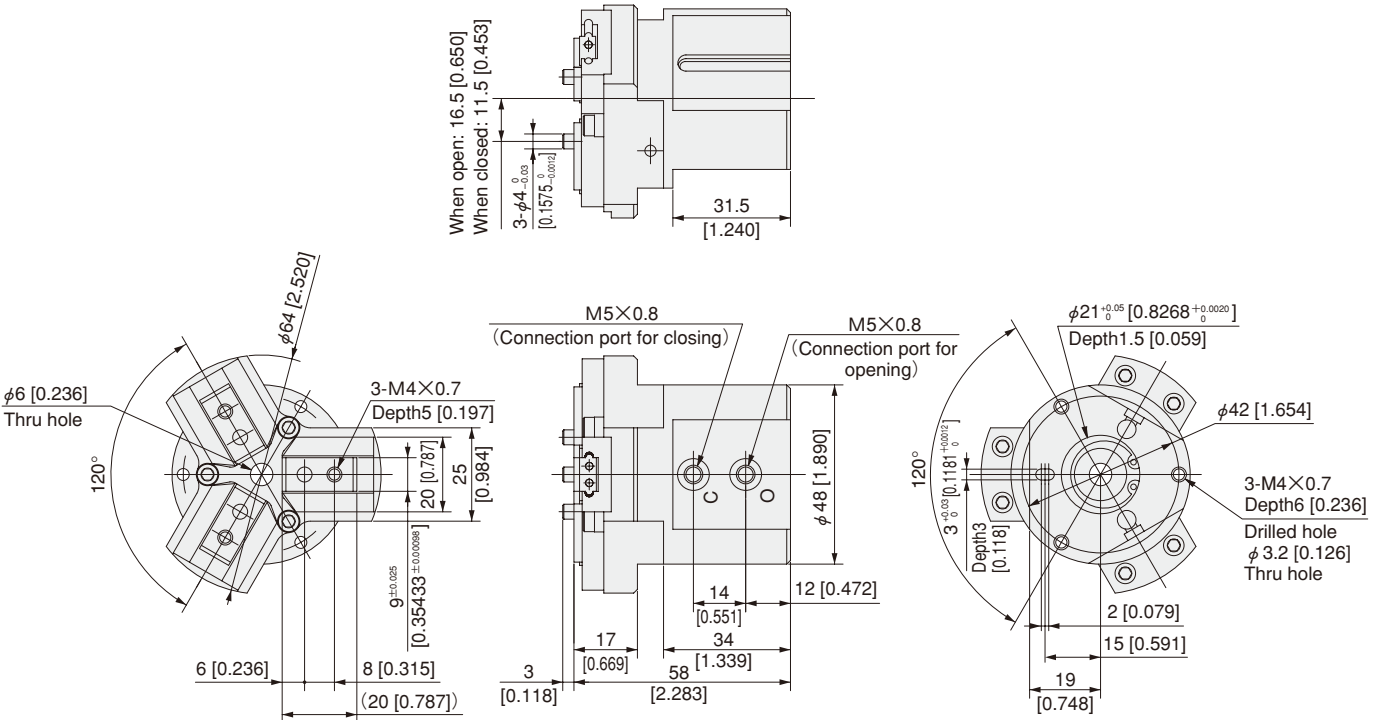

NHE1D-25

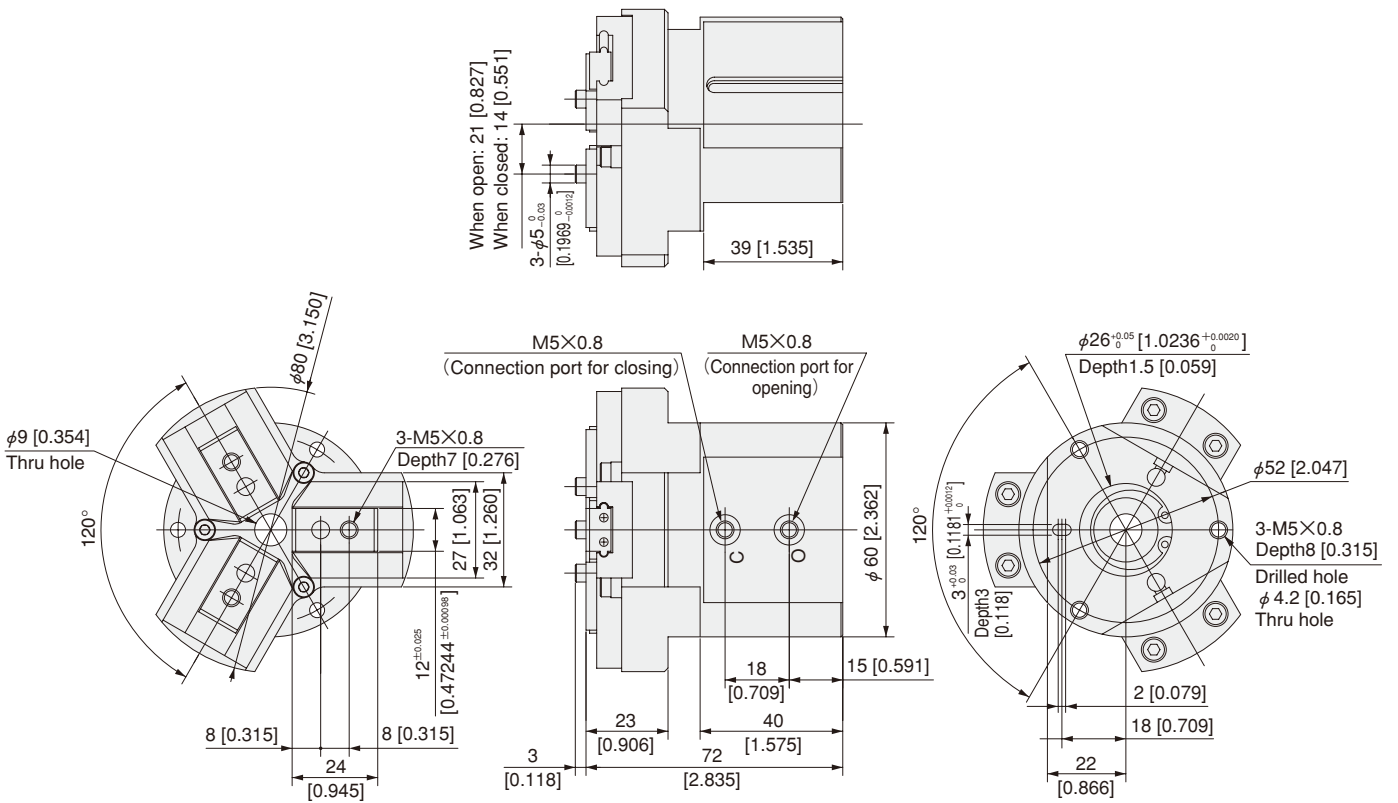

Application Examples

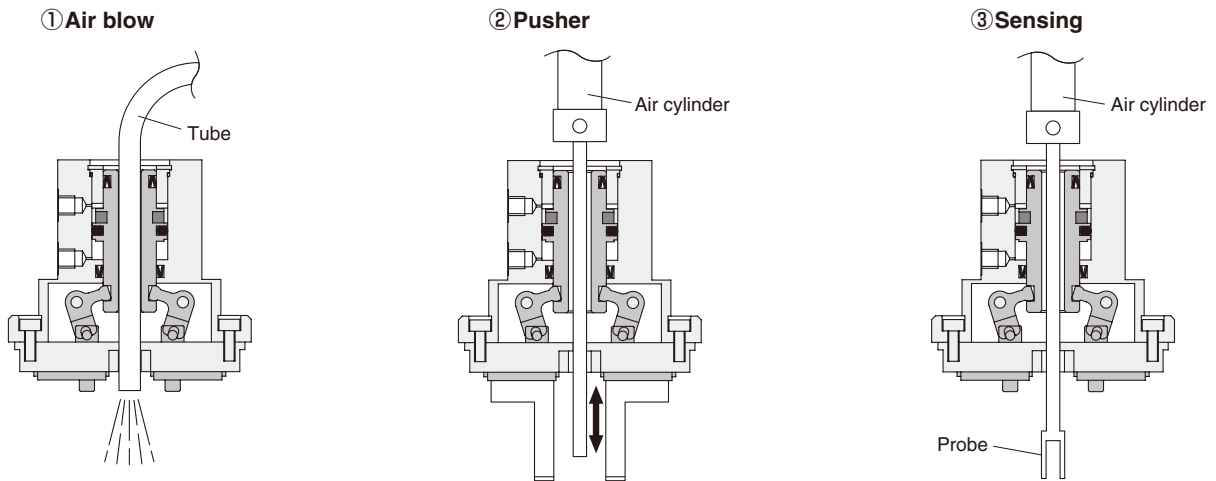

NHB SERIES PARALLEL TYPE

Cross Roller Bearing Specification
Double Acting Type, Single Acting Normally Open Type

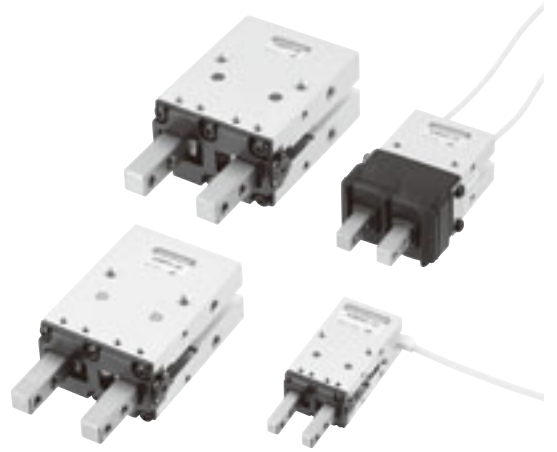

Symbols

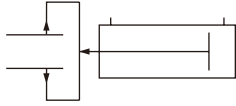

Double Acting Type

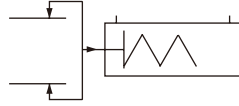

Single Acting
Normally Open Type

Specifications

● Double acting parallel type

Basic model		NHBDPA-6	NHBDPA-10	NHBDPA-16	NHBDPA-20	NHBDPA-25
Item						
Cylinder bore size	mm [in.]	6 [0.236]	10 [0.394]	16 [0.630]	20 [0.787]	25 [0.984]
Operation type		Double acting type				
Media		Air				
Operating pressure range	MPa [psi.]	0.22~0.7 [32~102]	0.18~0.7 [26~102]	0.12~0.7 [17~102]	0.1~0.7 [15~102]	
Proof pressure	MPa [psi.]	1.05 [152]				
Operating temperature range	°C [°F]	0~60 [32~140]				
Maximum operating frequency	cycle/min	100	200			
Lubrication	Cylinder portion	Not required				
	Lever portion	Not required				
Maximum grip point length	mm [in.]	20 [0.79]	50 [1.97]	60 [2.36]	80 [3.15]	100 [3.94]
Effective gripping force (F) ^{Note}	Closed side	4.2 [0.94]	9.4 [2.11]	25.5 [5.73]	45.7 [10.27]	67 [15.06]
	Open side	5.6 [1.26]	14.6 [3.28]	34 [7.64]	60.9 [13.69]	87 [19.56]
Lever open/closed stroke	mm [in.]	4 [0.157]		8 [0.315]	12 [0.472]	14 [0.551]
Repeatability	mm [in.]	±0.01 [±0.0004]				
Port size		M3×0.5			M5×0.8	
Mass	g [oz.]					
	Body	28 [0.99]	48 [1.69]	120 [4.23]	218 [7.69]	366 [12.91]
	Mounting bracket	—	11 [0.39]	19 [0.67]	26 [0.92]	51 [1.80]
Rubber cover	—	NBR: 6 [0.21] Silicone: 6 [0.21] Fluoro rubber: 7 [0.25]		NBR: 8 [0.28] Silicone: 8 [0.28] Fluoro rubber: 10 [0.35]		NBR: 12 [0.42] Silicone: 12 [0.42] Fluoro rubber: 16 [0.56]

Note: Values are obtained when grip point length is 30mm [1.18in.] under operating pressure 0.5 MPa [73psi.]. For details of the effective gripping force, see the graphs on p.1387.

Remark: The life of rubber cover may vary from the air hand (gripper), depending on its operating conditions.

● Single acting normally open parallel type

Basic model		NHBRPA-6	NHBRPA-10	NHBRPA-16	NHBRPA-20	NHBRPA-25
Item						
Cylinder bore size	mm [in.]	6 [0.236]	10 [0.394]	16 [0.630]	20 [0.787]	25 [0.984]
Operation type		Single acting normally open type				
Media		Air				
Operating pressure range	MPa [psi.]	0.4~0.7 [58~102]	0.35~0.7 [51~102]	0.25~0.7 [36~102]		
Proof pressure	MPa [psi.]	1.05 [152]				
Operating temperature range	°C [°F]	0~60 [32~140]				
Maximum operating frequency	cycle/min	100	200			
Lubrication	Cylinder portion	Not required				
	Lever portion	Not required				
Maximum grip point length	mm [in.]	20 [0.79]	50 [1.97]	60 [2.36]	80 [3.15]	100 [3.94]
Effective gripping force (F) ^{Note}	Closed side	1.3 [0.29]	4.9 [1.10]	21 [4.72]	36.4 [8.18]	54 [12.14]
	Open side	2.7 [0.61]	2 [0.45]	3.9 [0.88]	6.9 [1.55]	13.7 [3.08]
Lever open/closed stroke	mm [in.]	4 [0.157]		8 [0.315]	12 [0.472]	14 [0.551]
Repeatability	mm [in.]	±0.01 [±0.0004]				
Port size		M3×0.5			M5×0.8	
Mass	g [oz.]					
	Body	27 [0.95]	49 [1.73]	121 [4.27]	220 [7.76]	368 [12.98]
	Mounting bracket	—	11 [0.39]	19 [0.67]	26 [0.92]	51 [1.80]
Rubber cover	—	NBR: 6 [0.21] Silicone: 6 [0.21] Fluoro rubber: 7 [0.25]		NBR: 8 [0.28] Silicone: 8 [0.28] Fluoro rubber: 10 [0.35]		NBR: 12 [0.42] Silicone: 12 [0.42] Fluoro rubber: 16 [0.56]

Note: Values are obtained when grip point length is 30mm [1.18in.] under operating pressure 0.5 MPa [73psi.]. For details of the effective gripping force, see the graphs on p.1387.

Remark: The life of rubber cover may vary from the air hand (gripper), depending on its operating conditions.

Inner Construction

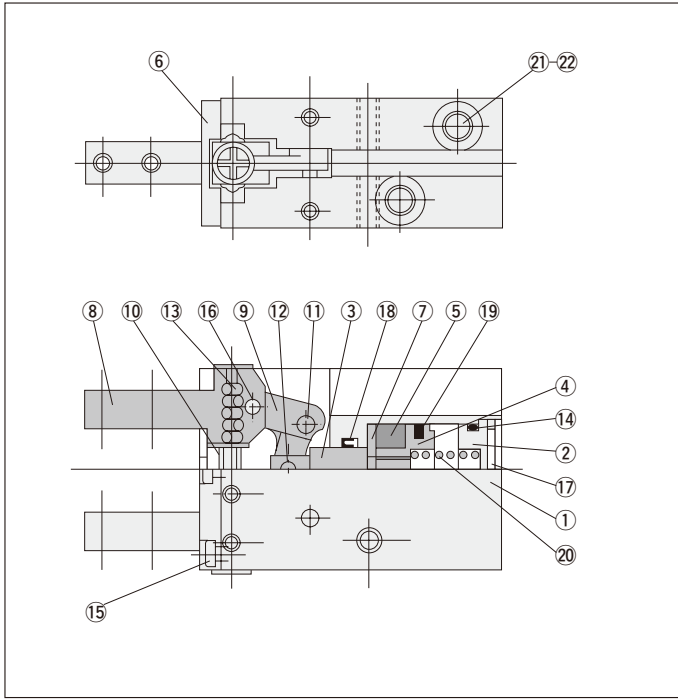

Major Parts and Materials

No.	Parts	Materials	Remarks
①	Body	Aluminum alloy	
②	Head cover	Aluminum alloy	
③	Piston rod	Stainless steel	
④	Piston	Aluminum alloy	
⑤	Magnet	Plastic magnet	
⑥	Cover	Steel	
⑦	Cover	Aluminum alloy	
⑧	Lever	Stainless steel	
⑨	Action lever	Steel	
⑩	Rail	Steel	
⑪	Fulcrum pin	Steel	
⑫	Press fit pin	Steel	
⑬	Cylindrical roller	Steel	
⑭	O-ring	Synthetic rubber (NBR)	
⑮	Cross recessed head screw	Mild steel	
⑯	Needle roller	Steel	
⑰	Snap ring	Steel	
⑱	Seal	Synthetic rubber (NBR)	
⑲	Seal	Synthetic rubber (NBR)	
⑳	Spring	Steel wire	Single acting type only
㉑	Plug	Brass	Single acting type only
㉒	Filter	Brass	Single acting type only

Order Codes

■ Rubber cover material

No rubber cover

Blank

With rubber cover

- **-JN:** NBR (Black with blue mark)
- **-JF:** Fluoro rubber (Black with green mark)
- **-JS:** Silicone rubber (White)

■ Mounting bracket

No mounting bracket

Blank

With mounting bracket

-M

★ Included at shipping

■ Sensor switch

No sensor switch

Blank

With ZE135

-ZE135

With ZE155

-ZE155

With ZE235

-ZE235

With ZE255

-ZE255

- Solid state type
- With indicator lamp
- DC10~28V
- 2-lead wire
- Horizontal lead wire

Note: Select vertical lead wires ZE235 or ZE255 when using a sensor switch on the lever open side of NHB□PA Air Hands.

■ Lead wire length

A : 1000mm [39in.]

B : 3000mm [118in.]

■ Number of sensor switches
(for air hands with sensor switches)

- 1 : With 1 sensor switch
- 2 : With 2 sensor switches

★ Included at shipping

Additional Parts (To be ordered separately)

Mounting bracket

- For φ 10 [0.394in.] —NHB-M10
- For φ 16 [0.630in.] —NHB-M16
- For φ 20 [0.787in.] —NHB-M20
- For φ 25 [0.984in.] —NHB-M25

Rubber cover

-NHB-DPA

Rubber cover material

JN: NBR (Black with blue mark)

JF: Fluoro rubber (Black with green mark)

JS: Silicone rubber (White)

Bore size

10 : φ 10 [0.394in.]

16 : φ 16 [0.630in.]

20 : φ 20 [0.787in.]

25 : φ 25 [0.984in.]

	Basic model	Cylinder bore size					
Double acting type	NHBDPA	-6					
		-10				-ZE135 -ZE155 -ZE235 -ZE255	A B
		-16	-JN		-M		1
		-20	-JF				2
		-25	-JS				
Single acting normally open type	NHBRPA	-6					
		-10				-ZE135 -ZE155 -ZE235 -ZE255	A B
		-16	-JN		-M		1
		-20	-JF				2
		-25	-JS				

Dimensions of Cross Roller Bearing Specification Parallel Type (mm)

NHB □ PA-6

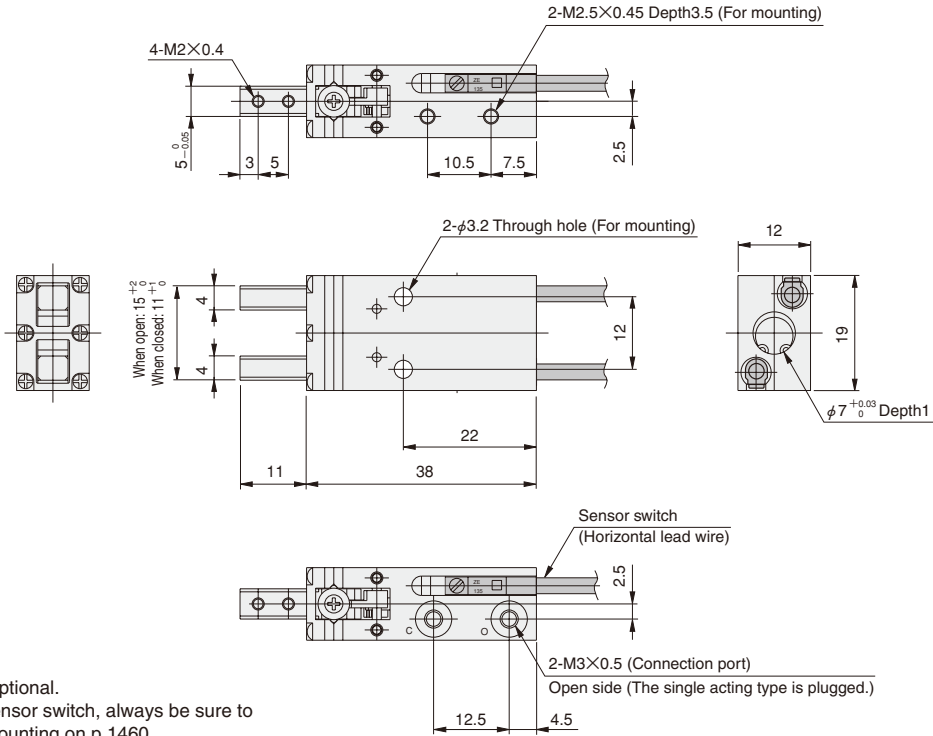

● The sensor switch is optional.
When mounting the sensor switch, always be sure to see the cautions for mounting on p.1460.

NHB □ PA-10 NHB □ PA-16 NHB □ PA-20 NHB □ PA-25



※ Drawings show φ 16 [0.630in.].

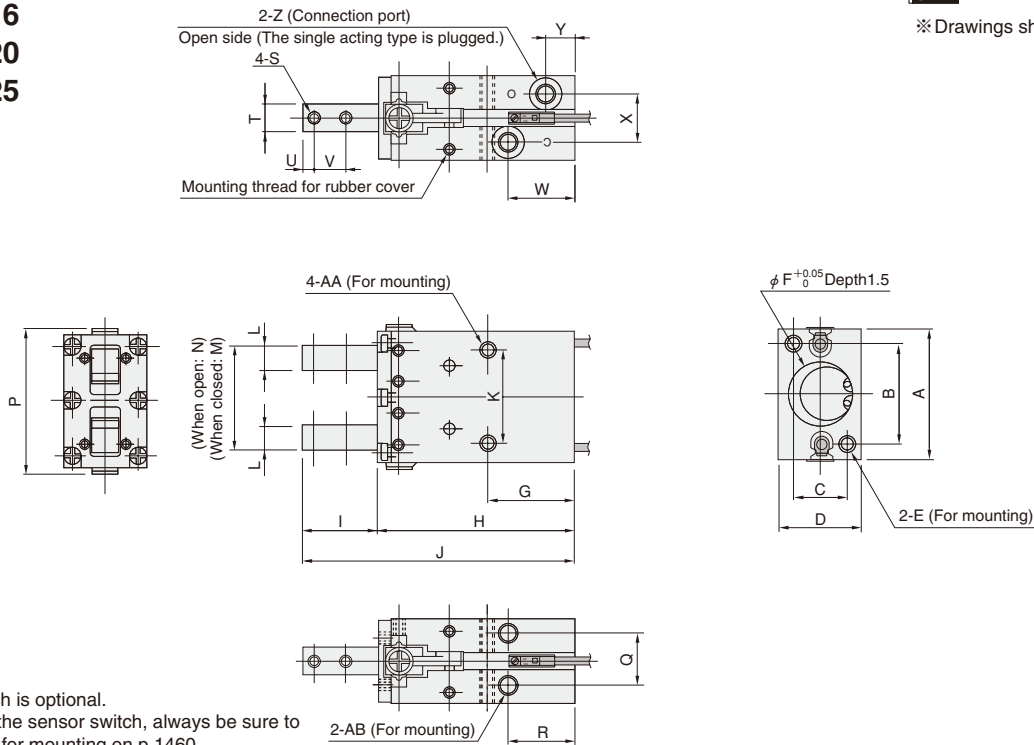

● The sensor switch is optional.
When mounting the sensor switch, always be sure to see the cautions for mounting on p.1460.

Model	Code	A	B	C	D	E	F	G	H	I	J	K	L	M	N
NHB □ PA-10		23	17	10	16	M3×0.5 Depth 5	11	20	43	16.5	59.5	18	4.5	13 ±0.4	17 ^{+1.6} _{-0.2}
NHB □ PA-16		34	26	14	22	M4×0.7 Depth 7	17	23	52	19	71	24	6.5	18 ^{+0.6} _{-0.2}	26 ^{+2.3} ₋₀
NHB □ PA-20		45	35	16	26	M5×0.8 Depth 8	21	26	60.5	23	83.5	30	8.5	24 ^{+0.1} _{-0.9}	36 ^{+1.5} _{-0.9}
NHB □ PA-25		52	40	20	32	M6×1 Depth 10	26	30	68	27	95	36	10	28 ±0.4	42 ^{+1.0} _{-0.7}

P	Q	R	S	T	U	V	W	X	Y	Z	AA	AB
25	10	16	M3×0.5	5.5 ⁰ _{-0.03}	3	6	15	10	7.5	M3×0.5	M3×0.5 Depth 5	M3×0.5 Depth 5
37.5	14	18	M3×0.5	7 ⁰ _{-0.03}	3	8	17.5	12	7.5	M5×0.8	M4×0.7 Depth 7	M4×0.7 Depth 7
49	16	19	M4×0.7	8 ⁰ _{-0.04}	4	10	20	13	8	M5×0.8	M5×0.8 Depth 8	M5×0.8 Depth 8
57.5	20	22	M5×0.8	10 ⁰ _{-0.03}	5	12	23	18	9	M5×0.8	M6×1 Depth 10	M6×1 Depth 10

Dimensions of Cross Roller Bearing Specification Parallel Type with Rubber Cover (mm)

※ Drawings show $\phi 16$ [0.630in.].

- NHB PA-10-J
- NHB PA-16-J
- NHB PA-20-J
- NHB PA-25-J

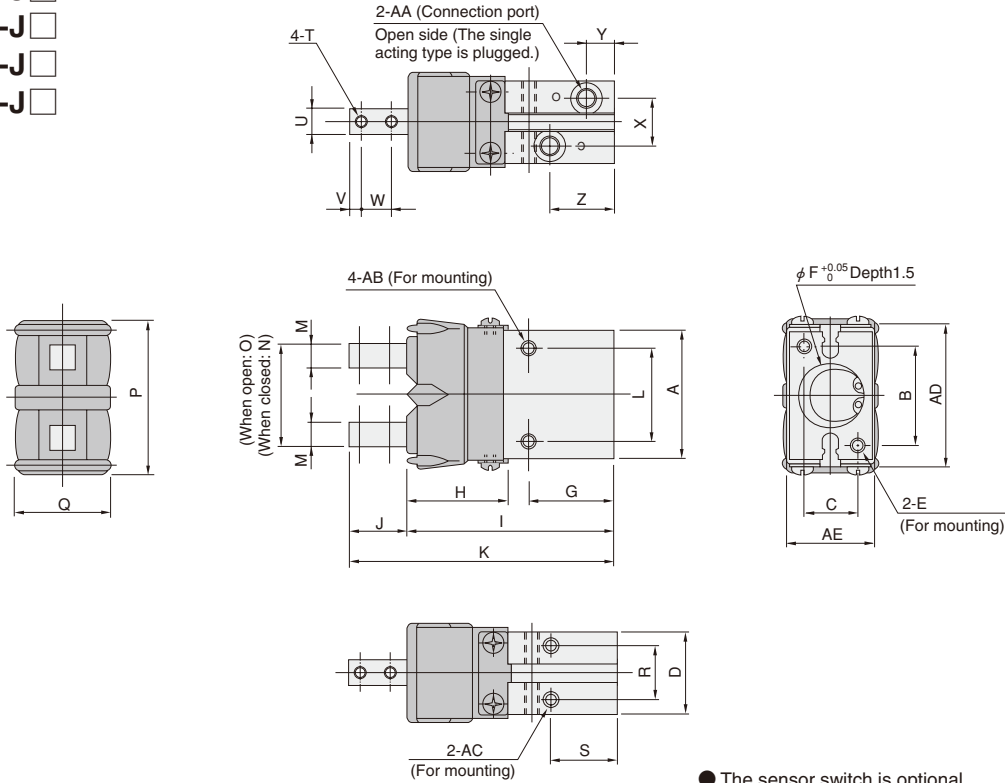

● The sensor switch is optional.
When mounting the sensor switch, always be sure to see the cautions for mounting on p.1460.

Model	Code	A	B	C	D	E	F	G	H	I	J	K	L	M	N	O
NHB <input type="checkbox"/> PA-10-J <input type="checkbox"/>		23	17	10	16	M3×0.5 Depth 5	11	20	22.5	46.5	13	59.5	18	4.5	13 ± 0.4	17 $\begin{smallmatrix} +1.6 \\ -0.2 \end{smallmatrix}$
NHB <input type="checkbox"/> PA-16-J <input type="checkbox"/>		34	26	14	22	M4×0.7 Depth 7	17	23	27.5	56	15	71	24	6.5	18 $\begin{smallmatrix} +0.6 \\ -0.2 \end{smallmatrix}$	26 $\begin{smallmatrix} +2.3 \\ 0 \end{smallmatrix}$
NHB <input type="checkbox"/> PA-20-J <input type="checkbox"/>		45	35	16	26	M5×0.8 Depth 8	21	26	34	64.5	19	83.5	30	8.5	24 $\begin{smallmatrix} +0.1 \\ -0.9 \end{smallmatrix}$	36 $\begin{smallmatrix} +1.5 \\ -0.9 \end{smallmatrix}$
NHB <input type="checkbox"/> PA-25-J <input type="checkbox"/>		52	40	20	32	M6×1 Depth 10	26	30	38	73	22	95	36	10	28 ± 0.4	42 $\begin{smallmatrix} +1.0 \\ -0.7 \end{smallmatrix}$

P	Q	R	S	T	U	V	W	X	Y	Z	AA	AB	AC	AD	AE
27	20	10	16	M3×0.5	5.5 $\begin{smallmatrix} 0 \\ -0.03 \end{smallmatrix}$	3	6	10	7.5	15	M3×0.5	M3×0.5 Depth 5	M3×0.5 Depth 5	26.6	18
39	26	14	18	M3×0.5	7 $\begin{smallmatrix} 0 \\ -0.03 \end{smallmatrix}$	3	8	12	7.5	17.5	M5×0.8	M4×0.7 Depth 7	M4×0.7 Depth 7	37.6	24
51	30	16	19	M4×0.7	8 $\begin{smallmatrix} 0 \\ -0.04 \end{smallmatrix}$	4	10	13	8	20	M5×0.8	M5×0.8 Depth 8	M5×0.8 Depth 8	48.6	28
59	36	20	22	M5×0.8	10 $\begin{smallmatrix} 0 \\ -0.03 \end{smallmatrix}$	5	12	18	9	23	M5×0.8	M6×1 Depth 10	M6×1 Depth 10	55.6	34

Options

● Mounting bracket: -M

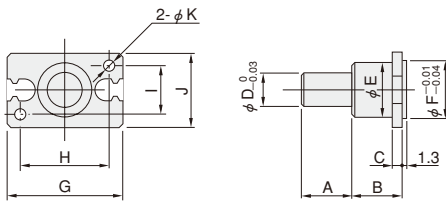

Model	Code	A	B	C	D	E	F	G	H	I	J	K
NHB-M10		15	15	3	10	11	11	23	17	10	16	3.4
NHB-M16		15	15	3	10	16	17	34	26	14	22	4.5
NHB-M20		15	15	3	10	18	21	45	35	16	26	5.5
NHB-M25		25	17	5	14	26	26	52	40	20	32	6.6

NHB SERIES PARALLEL TYPE

Plain Bearing Specification
Double Acting Type,
Single Acting Normally Open Type

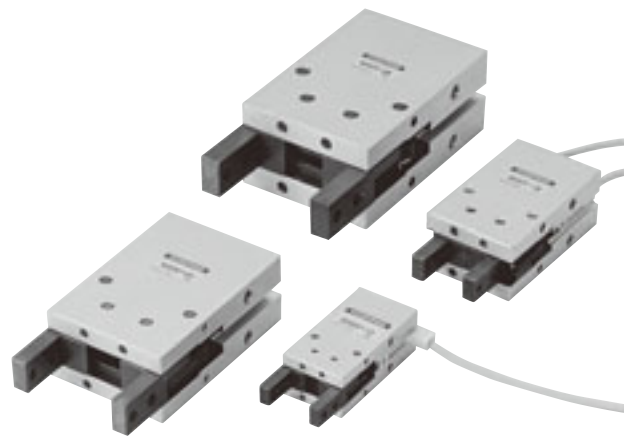

Symbols

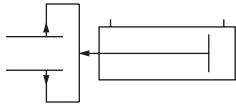

Double Acting Type

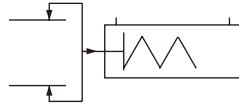

Single Acting
Normally Open Type

Specifications

● Double acting parallel type

Basic model		NHBDP-10	NHBDP-16	NHBDP-20	NHBDP-25
Item					
Cylinder bore size	mm [in.]	10 [0.394]	16 [0.630]	20 [0.787]	25 [0.984]
Operation type		Double acting type			
Media		Air			
Operating pressure range	MPa [psi.]	0.15~0.7 [22~102]	0.1~0.7 [15~102]		
Proof pressure	MPa [psi.]	1.05 [152]			
Operating temperature range	°C [°F]	0~60 [32~140]			
Maximum operating frequency	cycle/min	180			
Lubrication	Cylinder portion	Not required			
	Lever portion	Required (Apply grease to the sliding portion)			
Maximum grip point length	mm [in.]	30 [1.18]	40 [1.57]	60 [2.36]	70 [2.76]
Gripping force ^{Note 1} N [lbf.]	Closed side	7.8 [1.75]	23.5 [5.28]	46.1 [10.36]	76.5 [17.20]
	Open side	4.9 [1.10]	17.7 [3.98]	34.3 [7.71]	58.8 [13.22]
Lever open/closed stroke	mm [in.]	4 [0.157]	8 [0.315]	12 [0.472]	14 [0.551]
Port size		M3×0.5		M5×0.8	
Mass ^{Note 2}	g [oz.]	47 [1.66] (58 [2.05])	120 [4.23] (139 [4.90])	230 [8.11] (256 [9.03])	388 [13.69] (439 [15.49])

Notes: 1. Values are obtained when grip point length is 30mm [1.18in.] under operating pressure 0.5 MPa [73psi.]. For details of the effective gripping force, see the graphs on p.1387.

2. () mean the mass with the mounting bracket: -M.

● Single acting normally open parallel type

Basic model		NHBRP-10	NHBRP-16	NHBRP-20	NHBRP-25
Item					
Cylinder bore size	mm [in.]	10 [0.394]	16 [0.630]	20 [0.787]	25 [0.984]
Operation type		Single acting normally open type			
Media		Air			
Operating pressure range	MPa [psi.]	0.35~0.7 [51~102]	0.25~0.7 [36~102]		
Proof pressure	MPa [psi.]	1.05 [152]			
Operating temperature range	°C [°F]	0~60 [32~140]			
Maximum operating frequency	cycle/min	180			
Lubrication	Cylinder portion	Not required			
	Lever portion	Required (Apply grease to the sliding portion)			
Maximum grip point length	mm [in.]	30 [1.18]	40 [1.57]	60 [2.36]	70 [2.76]
Gripping force ^{Note 1} N [lbf.]	Closed side	2.9 [0.65]	12.7 [2.85]	22.6 [5.08]	37.3 [8.39]
	Open side	2.0 [0.45]	3.9 [0.88]	6.9 [1.55]	13.7 [3.08]
Lever open/closed stroke	mm [in.]	4 [0.157]	8 [0.315]	12 [0.472]	14 [0.551]
Port size		M3×0.5		M5×0.8	
Mass ^{Note 2}	g [oz.]	48 [1.69] (59 [2.08])	121 [4.27] (140 [4.94])	232 [8.18] (258 [9.10])	392 [13.83] (443 [15.63])

Notes: 1. Values are obtained when grip point length is 30mm [1.18in.] under operating pressure 0.5 MPa [73psi.]. For details of the effective gripping force, see the graphs on p.1387.

2. () mean the mass with the mounting bracket: -M.

Inner Construction

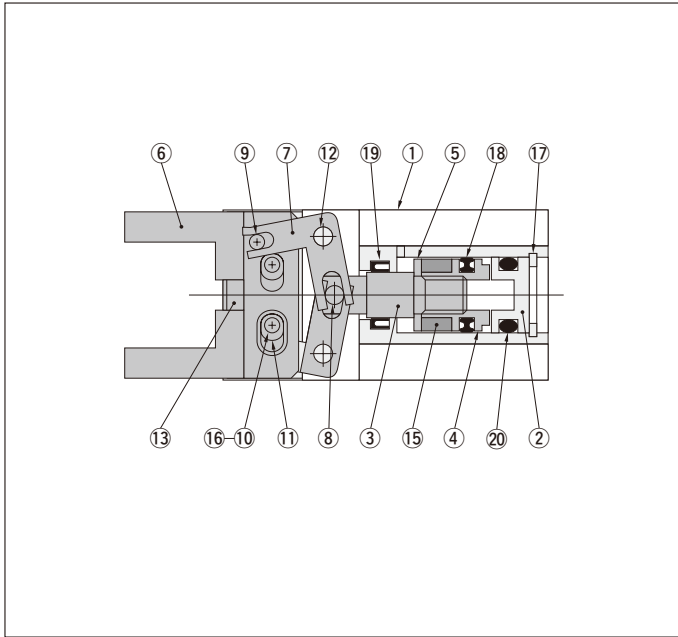





Note: Diagram shows the double acting type with the levers completely opened.

Major Parts and Materials

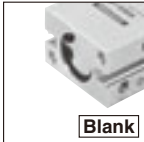
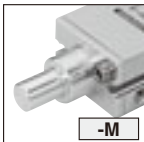
No.	Parts	Materials	Remarks
①	Body	Aluminum alloy	
②	Head cover	Aluminum alloy	
③	Piston rod	Stainless steel	
④	Piston	Aluminum alloy	
⑤	Magnet holder	Aluminum alloy	
⑥	Slide lever	Carbon steel	
⑦	Action lever	Carbon steel	
⑧	Rod pin	Carbon steel	
⑨	Slide pin	Carbon steel	
⑩	Slide guide pin	Carbon steel	
⑪	Ring	Carbon steel	
⑫	Fulcrum pin	Carbon steel	
⑬	Slide plate	Carbon steel	
⑭	Spring	Spring steel	Single acting type only
⑮	Magnet	Magnet material	
⑯	Hexagon socket setscrew	Mild steel	
⑰	C-shaped snap ring	Steel	
⑱	Piston seal	Synthetic rubber (NBR)	
⑲	Rod seal	Synthetic rubber (NBR)	
⑳	O-ring	Synthetic rubber (NBR)	

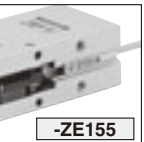
Order Codes

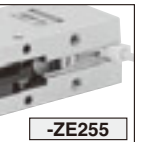
	Mounting bracket		Sensor switch					Lead wire length	Number of sensor switches (for air hands with sensor switches)
	No mounting bracket	With mounting bracket	No sensor switch	With ZE135	With ZE155	With ZE235	With ZE255		
	 Blank	 -M	 Blank	 -ZE135	 -ZE155	 -ZE235	 -ZE255	A : 1000mm [39in.] B : 3000mm [118in.]	● 1 : With 1 sensor switch ● 2 : With 2 sensor switches ★ Included at shipping
			<ul style="list-style-type: none"> ● Solid state type ● With indicator lamp ● DC10~28V ● 2-lead wire ● Horizontal lead wire 	<ul style="list-style-type: none"> ● Solid state type ● With indicator lamp ● DC4.5~28V ● 3-lead wire ● Horizontal lead wire 	<ul style="list-style-type: none"> ● Solid state type ● With indicator lamp ● DC10~28V ● 2-lead wire ● Vertical lead wire 	<ul style="list-style-type: none"> ● Solid state type ● With indicator lamp ● DC4.5~28V ● 3-lead wire ● Vertical lead wire 			
	Basic model	Cylinder bore size							
Double acting type	NHBDP	-10 -16 -20 -25	-M	-ZE135 -ZE155 -ZE235 -ZE255	A B	1 2			
Single acting normally open type	NHBRP	-10 -16 -20 -25	-M	-ZE135 -ZE155 -ZE235 -ZE255	A B	1 2			

Additional Parts (To be ordered separately)

Mounting bracket



- For ϕ 10 [0.394in.]
— NHB-M10
- For ϕ 16 [0.630in.]
— NHB-M16
- For ϕ 20 [0.787in.]
— NHB-M20
- For ϕ 25 [0.984in.]
— NHB-M25

Dimensions of Parallel Type Plain Bearing Specification (mm)

NHBDP-10 NHBRP-10

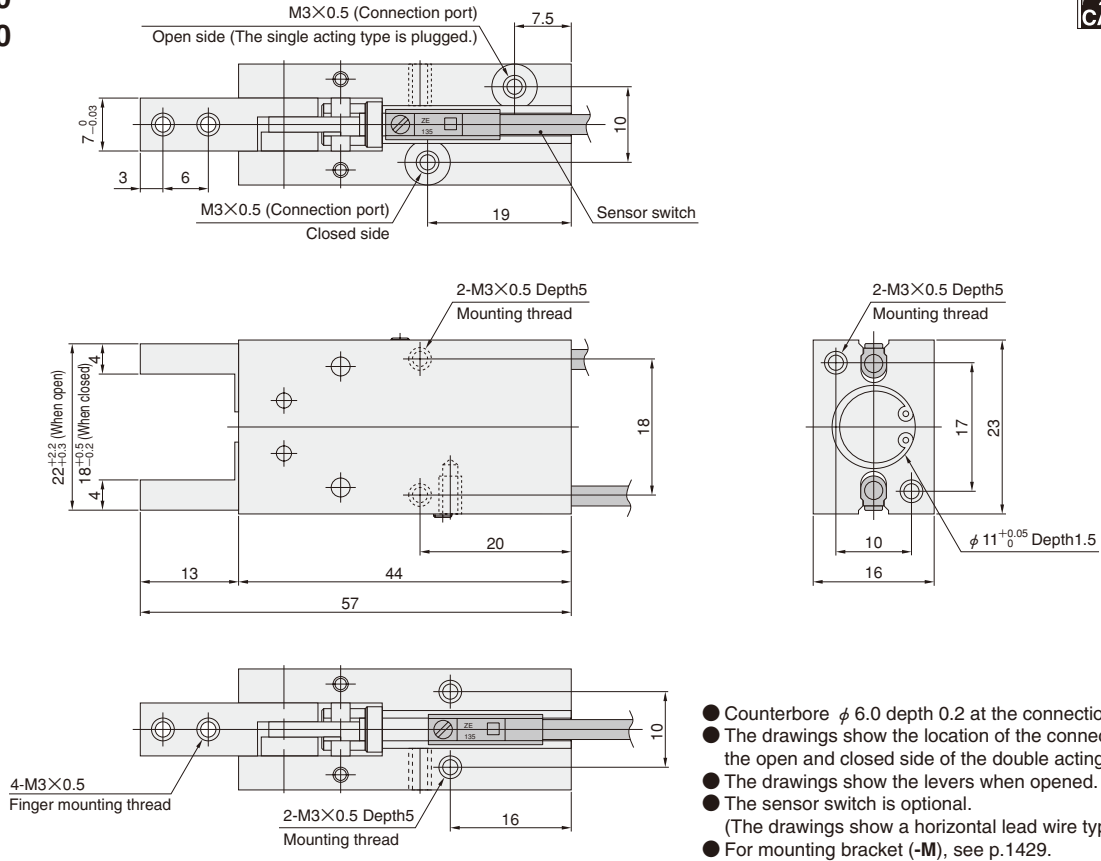

- Counterbore $\phi 6.0$ depth 0.2 at the connection port.
- The drawings show the location of the connection ports for the open and closed side of the double acting type.
- The drawings show the levers when opened.
- The sensor switch is optional.
(The drawings show a horizontal lead wire type.)
- For mounting bracket (-M), see p.1429.

NHBDP-16 NHBRP-16

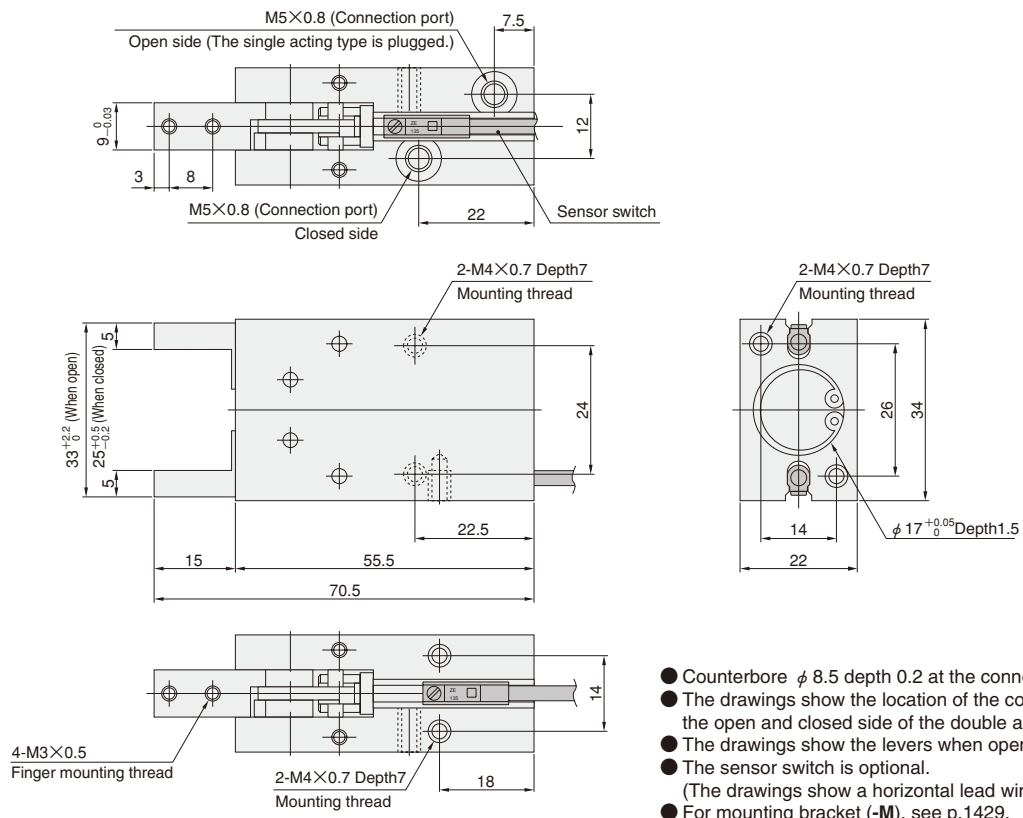

- Counterbore $\phi 8.5$ depth 0.2 at the connection port.
- The drawings show the location of the connection ports for the open and closed side of the double acting type.
- The drawings show the levers when opened.
- The sensor switch is optional.
(The drawings show a horizontal lead wire type.)
- For mounting bracket (-M), see p.1429.

Dimensions of Parallel Type Plain Bearing Specification (mm)

NHBDP-20 NHBRP-20

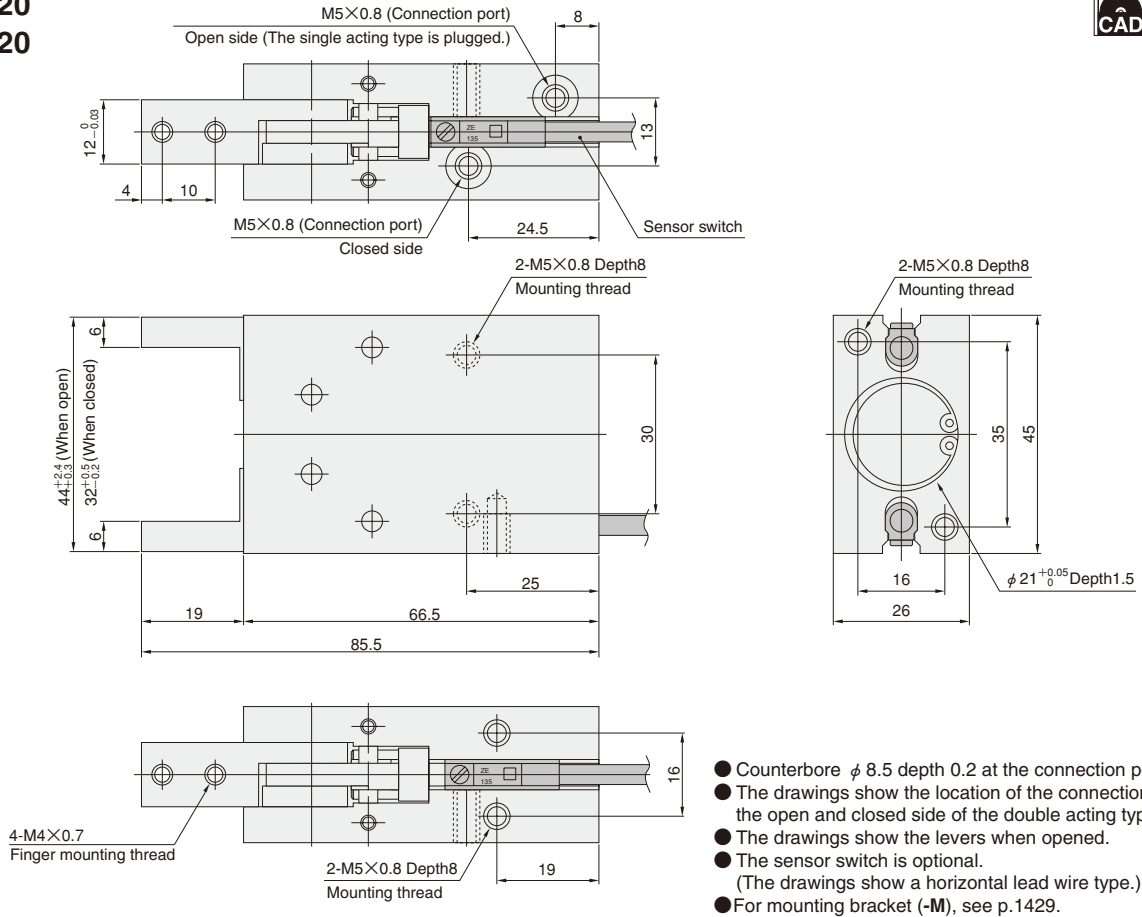

- Counterbore $\phi 8.5$ depth 0.2 at the connection port.
- The drawings show the location of the connection ports for the open and closed side of the double acting type.
- The drawings show the levers when opened.
- The sensor switch is optional.
(The drawings show a horizontal lead wire type.)
- For mounting bracket (-M), see p.1429.

NHBDP-25 NHBRP-25

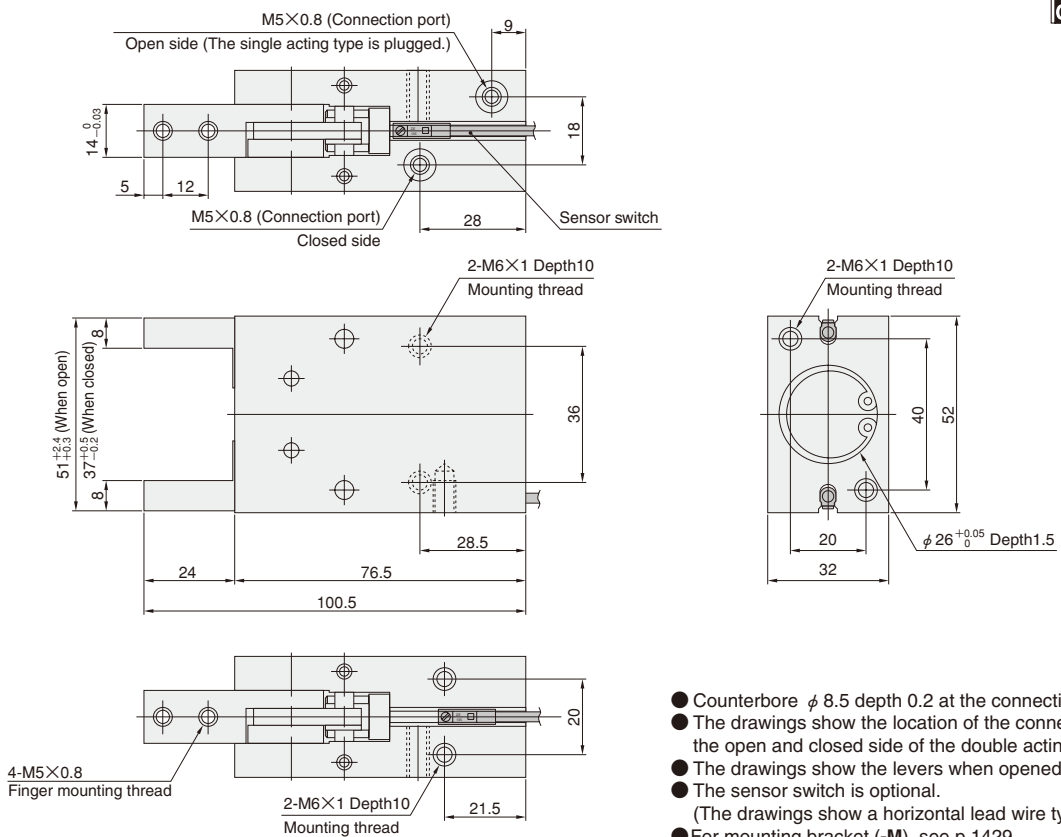

- Counterbore $\phi 8.5$ depth 0.2 at the connection port.
- The drawings show the location of the connection ports for the open and closed side of the double acting type.
- The drawings show the levers when opened.
- The sensor switch is optional.
(The drawings show a horizontal lead wire type.)
- For mounting bracket (-M), see p.1429.

NHB SERIES SWING TYPE

Double Acting Type,
Single Acting Normally Open Type

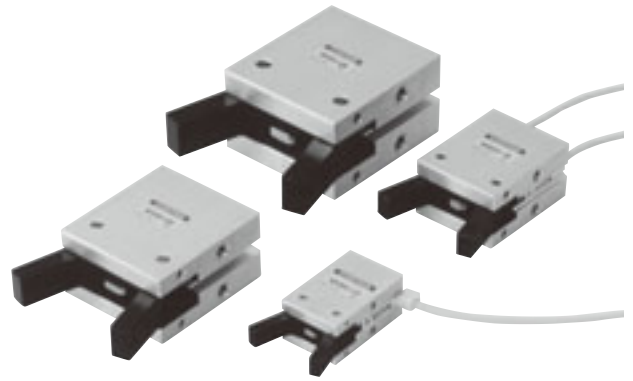

Symbols

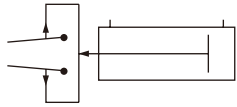

Double Acting Type

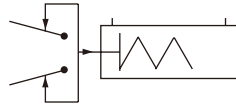

Single Acting
Normally Open Type

Specifications

● Double acting swing type

Basic model		NHBDS-8	NHBDS-10	NHBDS-16	NHBDS-20	NHBDS-25
Item						
Cylinder bore size	mm [in.]	8 [0.315]	10 [0.394]	16 [0.630]	20 [0.787]	25 [0.984]
Operation type		Double acting type				
Media		Air				
Operating pressure range	MPa [psi.]	0.22~0.7 [32~102]	0.1~0.7 [15~102]			
Proof pressure	MPa [psi.]	1.05 [152]				
Operating temperature range	°C [°F]	0~60 [32~140]				
Maximum operating frequency	cycle/min	100	180			
Lubrication	Cylinder portion	Not required				
	Lever portion	Required (Apply grease to the sliding portion)				
Theoretical gripping moment (M) ^{Note1} N·cm [in·lbf]	Closed side	9×P [0.0055×P]	17×P [0.0104×P]	90×P [0.0549×P]	170×P [0.104×P]	340×P [0.208×P]
	Open side	15×P [0.0092×P]	27×P [0.0165×P]	120×P [0.0732×P]	230×P [0.140×P]	440×P [0.269×P]
Maximum grip point length ^{Note2}	mm [in.]	30 [1.18]		40 [1.57]	60 [2.36]	70 [2.76]
Effective gripping force (F) ^{Note1}	N [lbf.]	F=M/L×8.5 [F=M/L×0.85]				
Lever open/closed angles		-10°~+30°				
Port size		M3×0.5			M5×0.8	
Mass ^{Note3}	g [oz.]	23 [0.81] (28 [0.99])	40 [1.41] (51 [1.80])	96 [3.39] (115 [4.06])	180 [6.35] (206 [7.27])	313 [11.04] (364 [12.84])

Notes: 1. F: Effective gripping force, M: Theoretical gripping moment, P: Operating pressure MPa [psi.], L: Grip point length mm [in.]. Values of P and L should vary from SI unit to imperial units. For details of the effective gripping force, see the graphs on p.1388.

2. The grip point length is measured from the fulcrum pin.

3. () mean the mass with the mounting bracket: -M.

● Single acting normally open swing type

Basic model		NHBRS-8	NHBRS-10	NHBRS-16	NHBRS-20	NHBRS-25
Item						
Cylinder bore size	mm [in.]	8 [0.315]	10 [0.394]	16 [0.630]	20 [0.787]	25 [0.984]
Operation type		Single acting normally open type				
Media		Air				
Operating pressure range	MPa [psi.]	0.36~0.7 [52~102]	0.3~0.7 [44~102]	0.2~0.7 [29~102]		
Proof pressure	MPa [psi.]	1.05 [152]				
Operating temperature range	°C [°F]	0~60 [32~140]				
Maximum operating frequency	cycle/min	100	180			
Lubrication	Cylinder portion	Not required				
	Lever portion	Required (Apply grease to the sliding portion)				
Theoretical gripping moment (M) ^{Note1} N·cm [in·lbf]	Closed side	9×P-2.5 [0.0055×P-0.22]	17×P-3.4 [0.0104×P-0.30]	90×P-9.8 [0.0549×P-0.87]	170×P-20.5 [0.104×P-1.81]	340×P-35.3 [0.208×P-3.12]
	Open side	2.5 [0.22]	3.4 [0.30]	9.8 [0.87]	20.5 [1.81]	35.3 [3.12]
Maximum grip point length ^{Note2}	mm [in.]	30 [1.18]		40 [1.57]	60 [2.36]	70 [2.76]
Effective gripping force (F) ^{Note1}	N [lbf.]	F=M/L×8.5 [F=M/L×0.85]				
Lever open/closed angles		-10°~+30°				
Port size		M3×0.5			M5×0.8	
Mass ^{Note3}	g [oz.]	23 [0.81] (28 [0.99])	40 [1.41] (51 [1.80])	96 [3.39] (115 [4.06])	182 [6.42] (208 [7.34])	317 [11.18] (368 [12.98])

Notes: 1. F: Effective gripping force, M: Theoretical gripping moment, P: Operating pressure MPa [psi.], L: Grip point length mm [in.]. Values of P and L should vary from SI unit to imperial units. For details of the effective gripping force, see the graphs on p.1388.

2. The grip point length is measured from the fulcrum pin.

3. () mean the mass with the mounting bracket: -M.

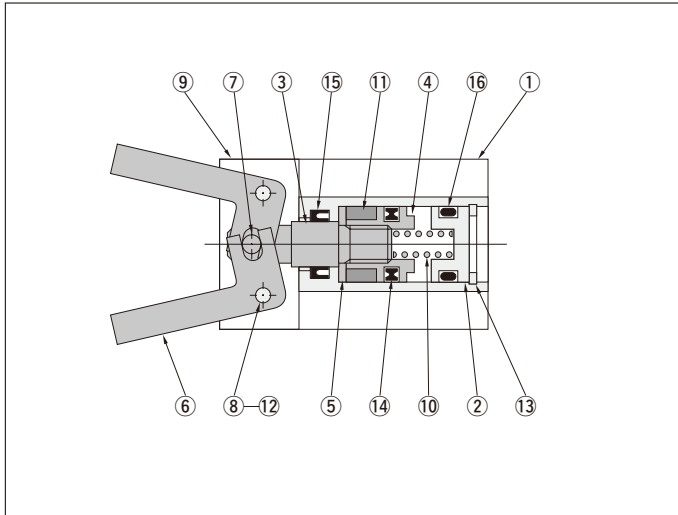

Inner Construction



Major Parts and Materials

No.	Parts	Materials	Remarks
①	Body	Aluminum alloy	
②	Head cover	Aluminum alloy	
③	Piston rod	Stainless steel	
④	Piston	Aluminum alloy	
⑤	Magnet holder	Aluminum alloy	
⑥	Lever	Chrome molybdenum steel	
⑦	Rod pin	Carbon steel	
⑧	Fulcrum pin	Carbon steel	
⑨	Slide plate	Carbon steel	
⑩	Spring	Spring steel	Single acting type only
⑪	Magnet	Magnet material	
⑫	Hexagon socket setscrew	Mild steel	
⑬	C-shaped snap ring	Steel	
⑭	Piston seal	Synthetic rubber (NBR)	
⑮	Rod seal	Synthetic rubber (NBR)	
⑯	O-ring	Synthetic rubber (NBR)	

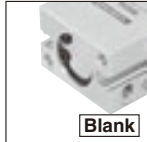
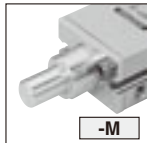
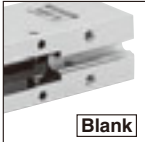
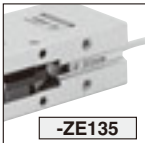
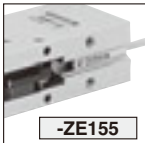
Order Codes

	Mounting bracket		Sensor switch				Lead wire length	Number of sensor switches (for air hands with sensor switches)
	No mounting bracket	With mounting bracket	No sensor switch	With ZE135	With ZE155	With ZE235		
	 Blank	 -M	 Blank	 -ZE135	 -ZE155	 -ZE235	 -ZE255	
	★ Included at shipping			<ul style="list-style-type: none"> ● Solid state type ● With indicator lamp ● DC10~28V ● 2-lead wire ● Horizontal lead wire 	<ul style="list-style-type: none"> ● Solid state type ● With indicator lamp ● DC4.5~28V ● 3-lead wire ● Horizontal lead wire 	<ul style="list-style-type: none"> ● Solid state type ● With indicator lamp ● DC10~28V ● 2-lead wire ● Vertical lead wire 	<ul style="list-style-type: none"> ● Solid state type ● With indicator lamp ● DC4.5~28V ● 3-lead wire ● Vertical lead wire 	
	Basic model	Cylinder bore size						
Double acting type	NHBDS	-8 -10 -16 -20 -25	-M	-ZE135 -ZE155 -ZE235 -ZE255	A B	1 2		
Single acting normally open type	NHBRS	-8 -10 -16 -20 -25	-M	-ZE135 -ZE155 -ZE235 -ZE255	A B	1 2		

Additional Parts (To be ordered separately)

Mounting bracket

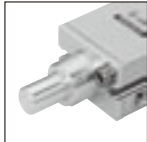

- For φ 8 [0.315in.]
— NHB-M8
- For φ 10 [0.394in.]
— NHB-M10
- For φ 16 [0.630in.]
— NHB-M16
- For φ 20 [0.787in.]
— NHB-M20
- For φ 25 [0.984in.]
— NHB-M25

Dimensions of Swing Type (mm)

NHBDS-8 NHBR-8

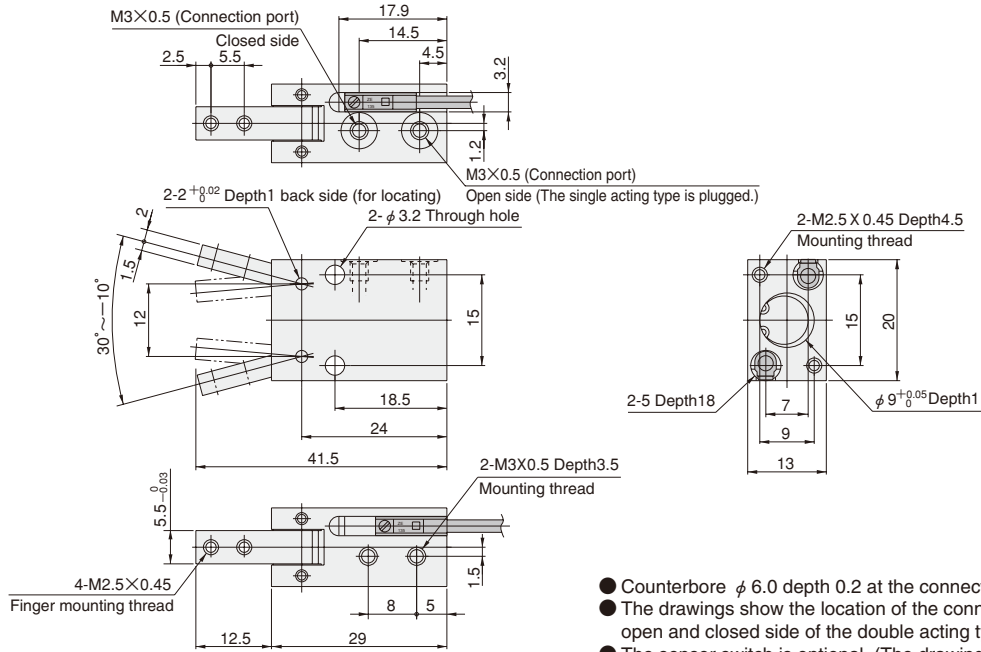

- Counterbore φ 6.0 depth 0.2 at the connection port.
- The drawings show the location of the connection ports for the open and closed side of the double acting type.
- The sensor switch is optional. (The drawings show a horizontal lead wire type.) When mounting the sensor switch, always be sure to see the cautions for mounting on p.1460.
- For mounting bracket (-M), see p.1438.

NHBDS-10 NHBR-10

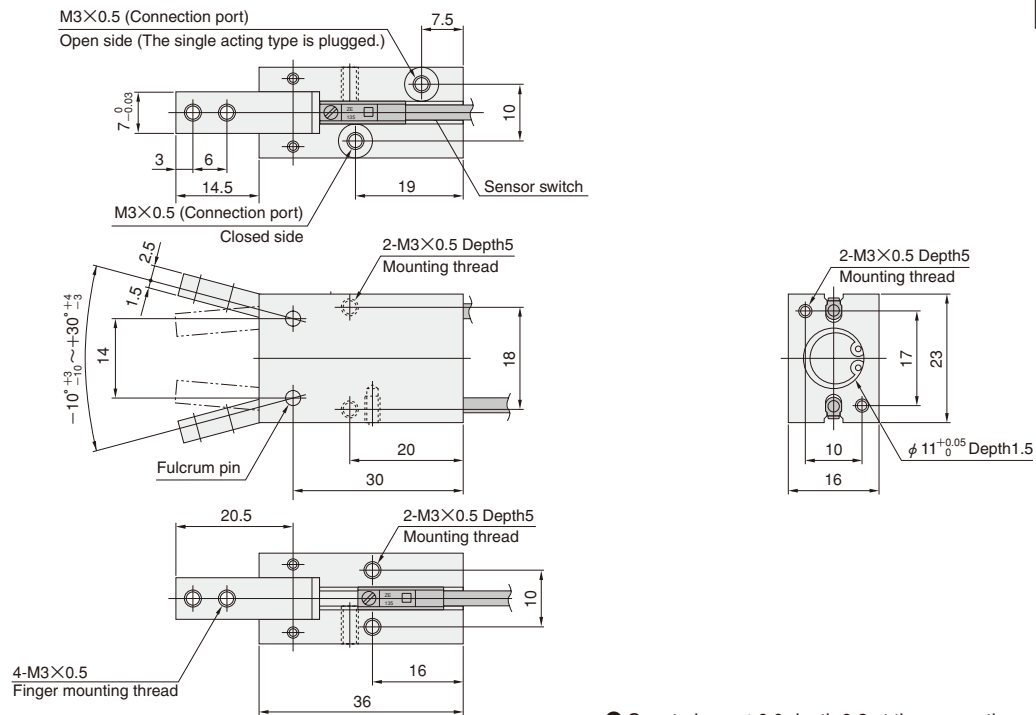

- Counterbore φ 6.0 depth 0.2 at the connection port.
- The drawings show the location of the connection ports for the open and closed side of the double acting type.
- The sensor switch is optional. (The drawings show a horizontal lead wire type.) When mounting the sensor switch always be sure to see the cautions for mounting on p.1460.
- For mounting bracket (-M), see p.1438.

Dimensions of Swing Type (mm)

NHBDS-16 NHBR-16

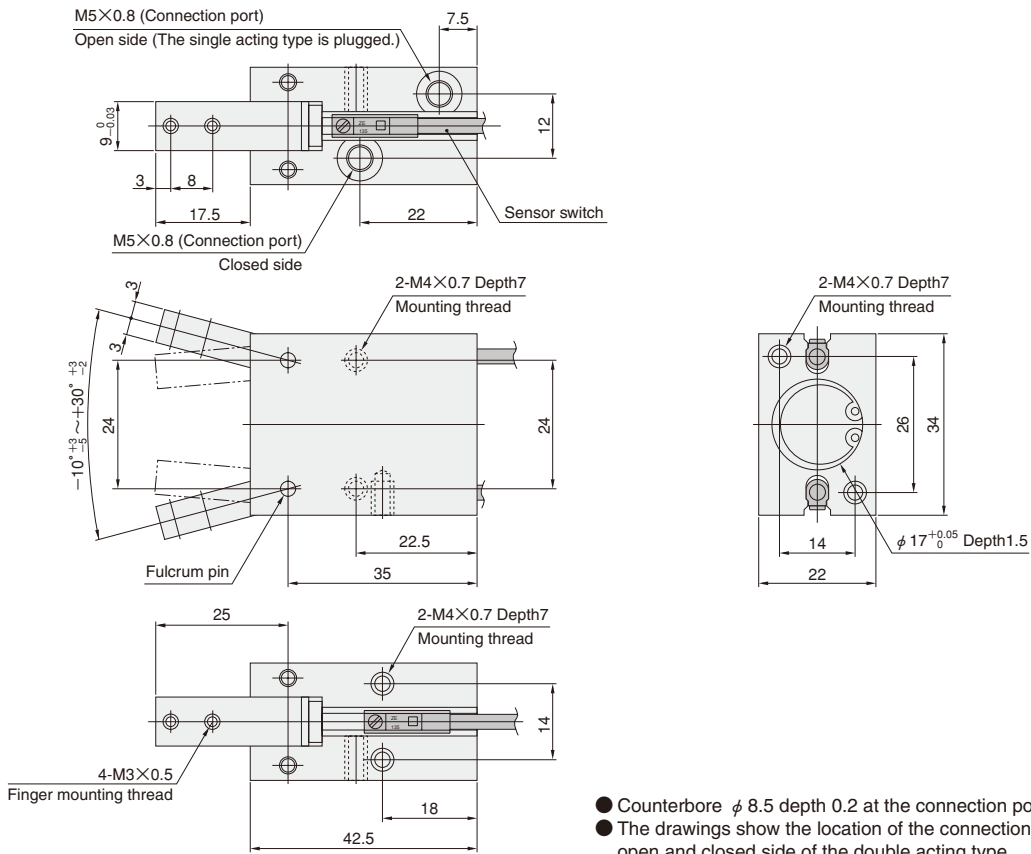

- Counterbore $\phi 8.5$ depth 0.2 at the connection port.
- The drawings show the location of the connection ports for the open and closed side of the double acting type.
- The sensor switch is optional. (The drawings show a horizontal lead wire type.) When mounting the sensor switch, always be sure to see the cautions for mounting on p.1460.
- For mounting bracket (-M), see p.1438.

NHBDS-20 NHBR-20

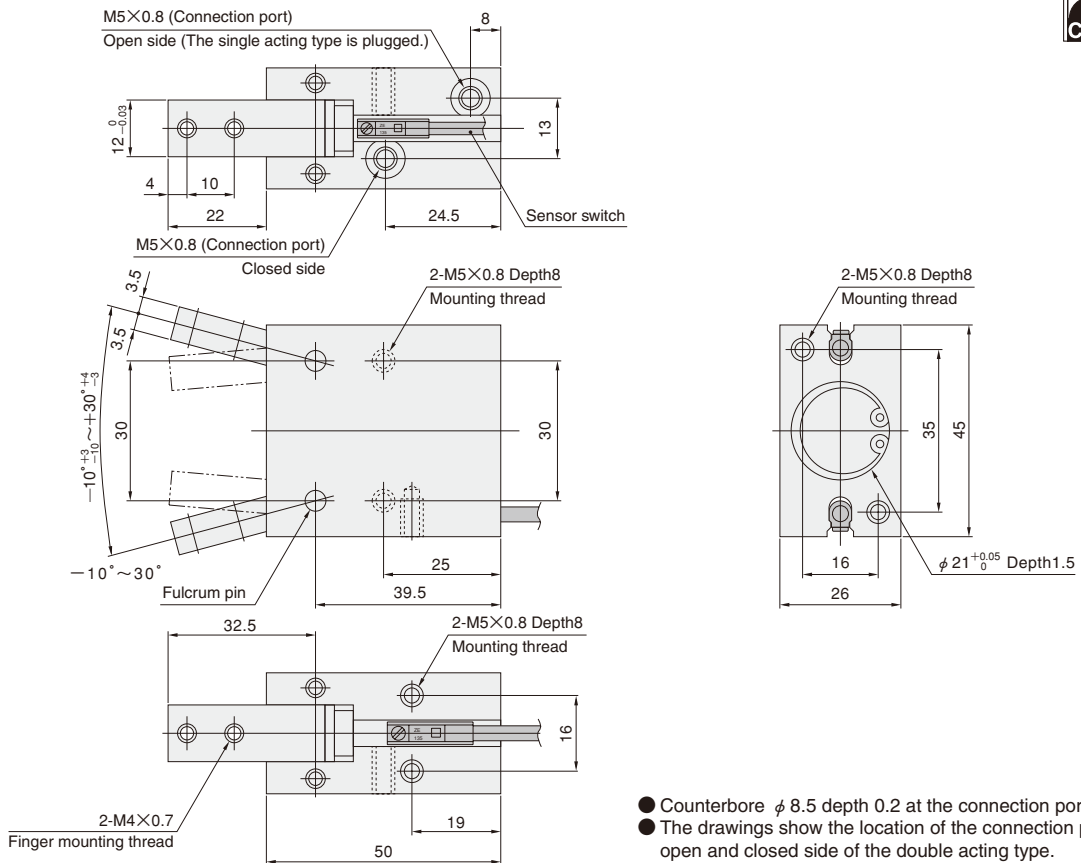

- Counterbore $\phi 8.5$ depth 0.2 at the connection port.
- The drawings show the location of the connection ports for the open and closed side of the double acting type.
- The sensor switch is optional. (The drawings show a horizontal lead wire type.) When mounting the sensor switch, always be sure to see the cautions for mounting on p.1460.
- For mounting bracket (-M), see p.1438.

Dimensions of Swing Type (mm)

NHBDS-25
NHBRS-25

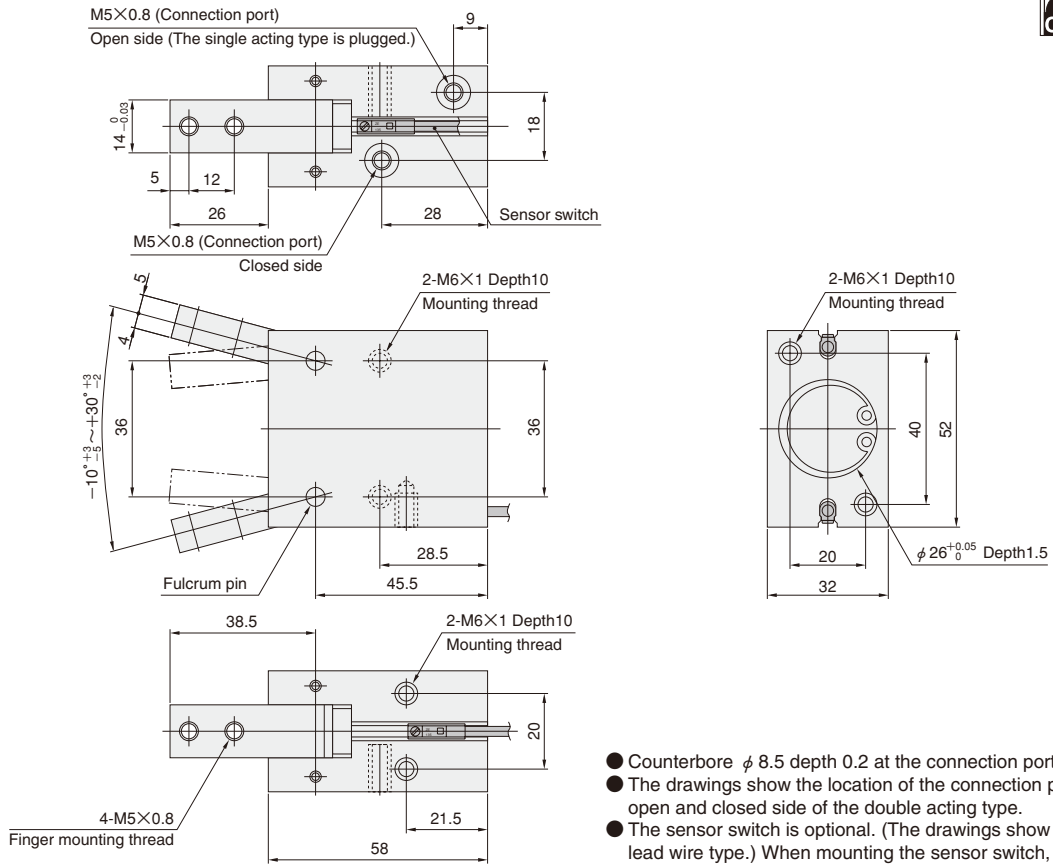

- Counterbore $\phi 8.5$ depth 0.2 at the connection port.
- The drawings show the location of the connection ports for the open and closed side of the double acting type.
- The sensor switch is optional. (The drawings show a horizontal lead wire type.) When mounting the sensor switch, always be sure to see the cautions for mounting on p.1460.
- For mounting bracket (-M), see below.

Options

- Mounting bracket: -M



Note: Except NHB-M8 and NHB-M12.

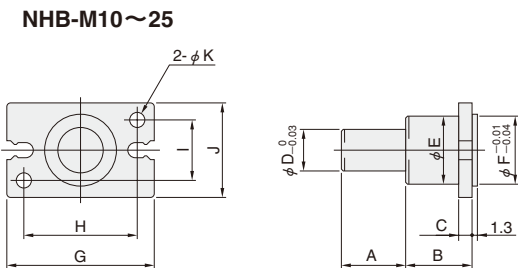
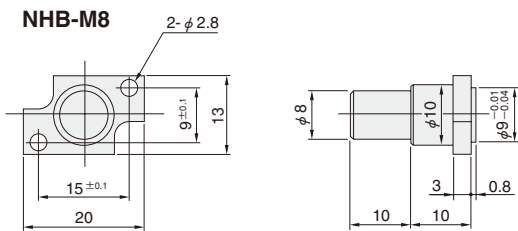

Model	Code	A	B	C	D	E	F	G	H	I	J	K
NHB-M10		15	15	3	10	11	11	23	17	10	16	3.4
NHB-M12		15	15	3	10	12	13	27	20	10	16	3.4
NHB-M16		15	15	3	10	16	17	34	26	14	22	4.5
NHB-M20		15	15	3	10	18	21	45	35	16	26	5.5
NHB-M25		25	17	5	14	26	26	52	40	20	32	6.6

NHB SERIES SWING TYPE

High Precision, 180° Open Specification

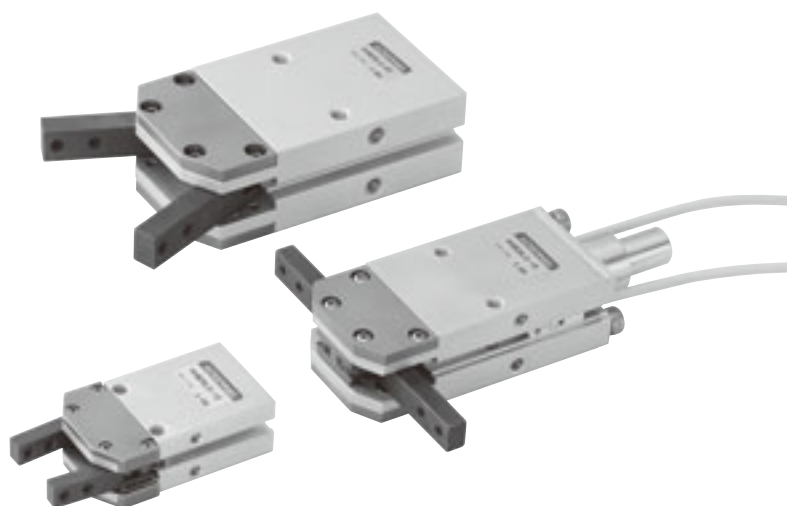

Symbol

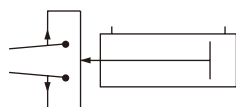

Double Acting Type

Specifications

● Double acting swing type

Basic model		NHBDSLGL-12	NHBDSLGL-16	NHBDSLGL-20
Item				
Cylinder bore size	mm [in.]	12 [0.472]	16 [0.630]	20 [0.984]
Operation type		Double acting type		
Media		Air		
Operating pressure range	MPa [psi.]	0.2~0.7 [29~102]		
Proof pressure	MPa [psi.]	1.05 [152]		
Operating temperature range	°C [°F]	0~60 [32~140]		
Maximum operating frequency	cycle/min	100		
Lubrication	Cylinder portion	Not required		
	Lever portion	Required (Apply grease to the sliding portion)		
Effective gripping force ^{Note}	Open	20/L [0.177/L]	55/L [0.487/L]	113/L [1.000/L]
	Closed	24/L [0.212/L]	64/L [0.566/L]	134/L [1.19/L]
Lever open/closed angles		-6° ± 3° ~ 180° ± 5°		
Port size		M3 × 0.5		M5 × 0.8
Mass	g [oz.]	63 [2.22] (73 [2.57])	168 [5.93] (187 [6.60])	312 [11.01] (338 [11.92])

Notes: 1. L expresses the length (mm [in.]) from the fulcrum pin to grip point. (Gripping at lever in parallel state) For details of the effective gripping force, see the graphs on p. 1388.

2. () means the mass with the mounting bracket: -M.

Inner Construction

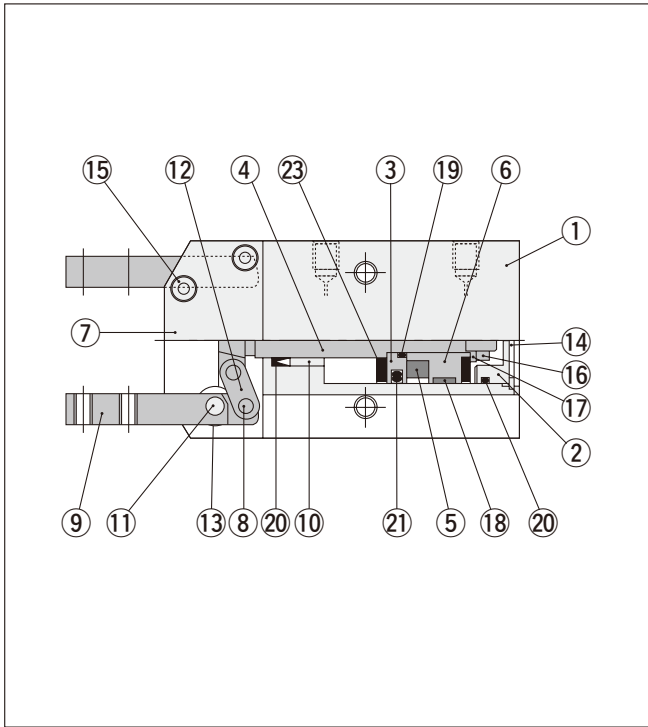









Major Parts and Materials

No.	Parts	Materials	Remarks
①	Body	Aluminum alloy	
②	Head cover	Aluminum alloy	
③	Piston	Aluminum alloy	
④	Piston rod	Stainless steel	
⑤	Magnet	Plastic magnet	
⑥	Magnet holder	Aluminum alloy	
⑦	Cover	Stainless steel	
⑧	Press fit pin	Steel	
⑨	Lever	Steel	
⑩	Metal	Oil impregnated copper alloy	
⑪	Fulcrum pin	Steel	
⑫	Link	Steel	
⑬	Bearing	Steel	
⑭	Internal snap ring	Steel	
⑮	Cross recessed round head screw	Stainless steel	
⑯	Hexagon nut	Stainless steel	
⑰	Spring washer	Stainless steel	
⑱	Wear ring	Plastic	Only ϕ 16 [0.630in.] and ϕ 20 [0.787in.]
⑳	O-ring	Synthetic rubber (NBR)	
㉑	O-ring	Synthetic rubber (NBR)	
㉒	Seal	Synthetic rubber (NBR)	
㉓	Seal	Synthetic rubber (NBR)	
㉔	Bumper	Synthetic rubber (NBR)	Only ϕ 16 [0.630in.] and ϕ 20 [0.787in.]

Order Codes

Double acting type	Basic model		Cylinder bore size				Lead wire length	Number of sensor switches (for air hands with sensor switches)
	NHBDSL	LG	-12	-16	-20	-M		
							A : 1000mm [39in.] B : 3000mm [118in.]	● 1 : With 1 sensor switch ● 2 : With 2 sensor switches ★ Included at shipping

Mounting bracket	Sensor switch
No mounting bracket  [Blank]	No sensor switch  [Blank]
With mounting bracket  [-M]	With ZE135  [-ZE135]
	With ZE155  [-ZE155]
	With ZE235  [-ZE235]
	With ZE255  [-ZE255]
★ Included at shipping	<ul style="list-style-type: none"> ● Solid state type ● With indicator lamp ● DC10~28V ● 2-lead wire ● Horizontal lead wire
	<ul style="list-style-type: none"> ● Solid state type ● With indicator lamp ● DC4.5~28V ● 3-lead wire ● Horizontal lead wire
	<ul style="list-style-type: none"> ● Solid state type ● With indicator lamp ● DC10~28V ● 2-lead wire ● Vertical lead wire
	<ul style="list-style-type: none"> ● Solid state type ● With indicator lamp ● DC4.5~28V ● 3-lead wire ● Vertical lead wire

Additional Parts (To be ordered separately)
Mounting bracket 
<ul style="list-style-type: none"> ● For ϕ 12 [0.472in.] — NHB-M12 ● For ϕ 16 [0.630in.] — NHB-M16 ● For ϕ 20 [0.787in.] — NHB-M20

NHBDSLGL-12

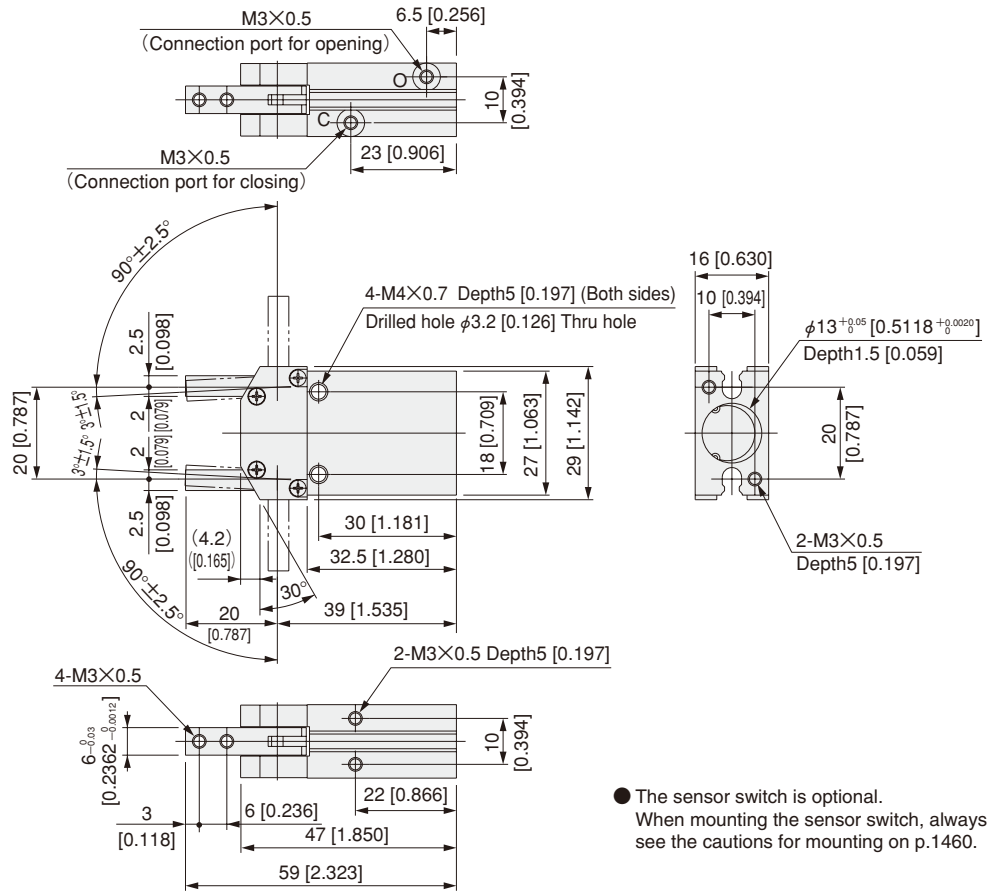

● The sensor switch is optional.
When mounting the sensor switch, always be sure to see the cautions for mounting on p.1460.

NHBDSLGL-16

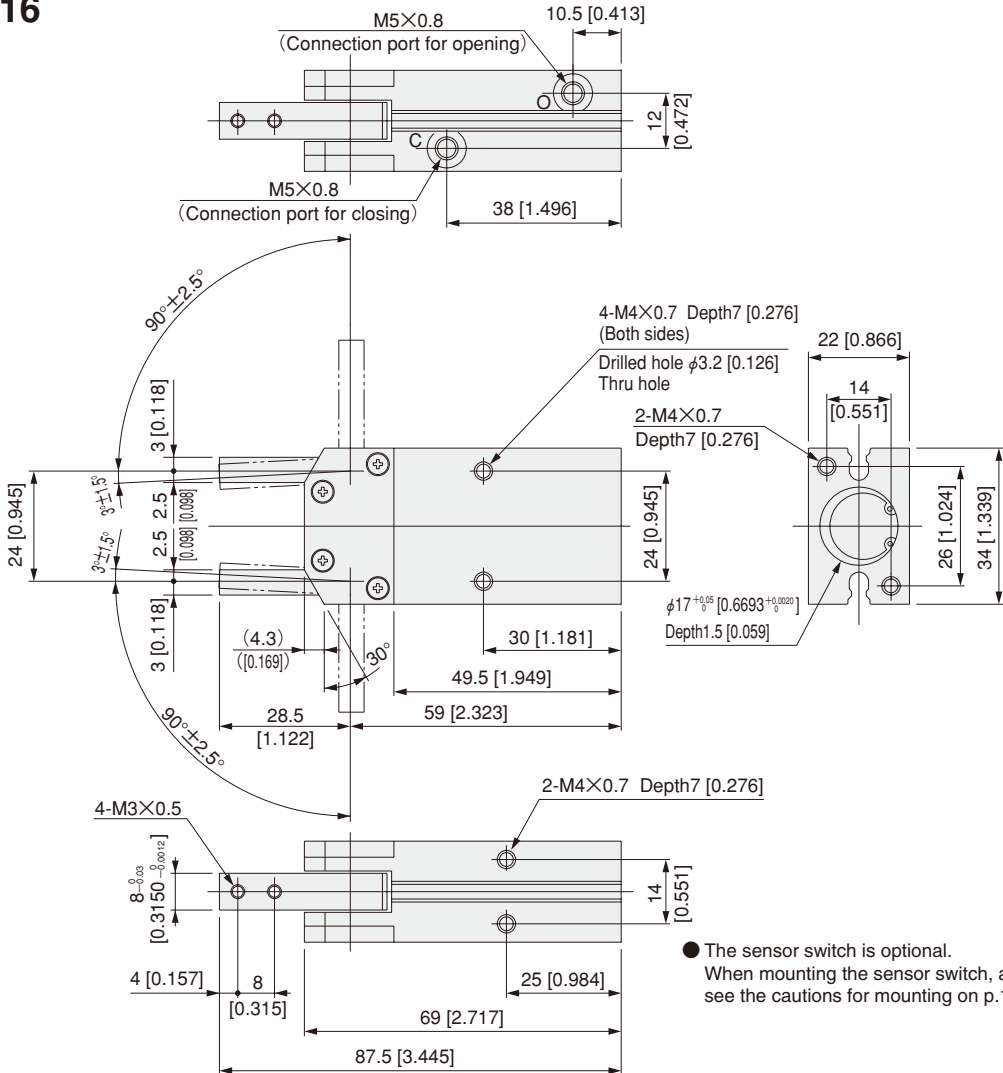

● The sensor switch is optional.
When mounting the sensor switch, always be sure to see the cautions for mounting on p.1460.

NHBDSLGL-20

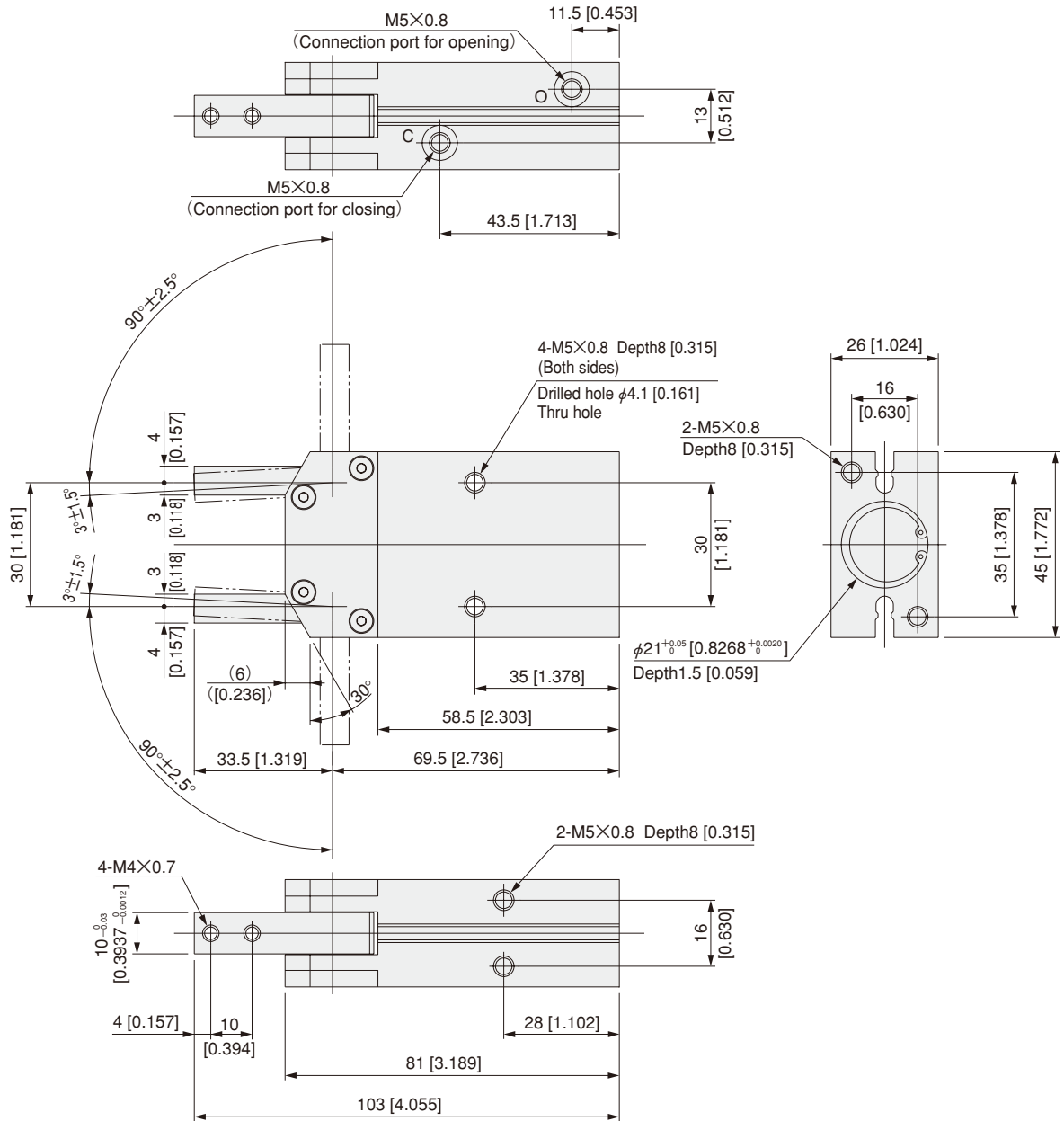

● The sensor switch is optional.
When mounting the sensor switch, always be sure to see the cautions for mounting on p.1460.

Options

● Mounting bracket: -M

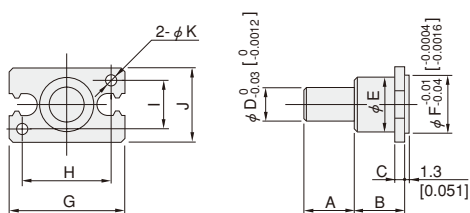

Model	Code	A	B	C	D	E	F	G	H	I	J	K
NHB-M12		15 [0.591]	15 [0.591]	3 [0.118]	10 [0.3937]	12 [0.472]	13 [0.5118]	27 [1.063]	20 [0.787]	10 [0.394]	16 [0.630]	3.4 [0.134]
NHB-M16		15 [0.591]	15 [0.591]	3 [0.118]	10 [0.3937]	16 [0.630]	17 [0.6693]	34 [1.339]	26 [1.024]	14 [0.551]	22 [0.866]	4.5 [0.177]
NHB-M20		15 [0.591]	15 [0.591]	3 [0.118]	10 [0.3937]	18 [0.709]	21 [0.8268]	45 [1.772]	35 [1.378]	16 [0.630]	26 [1.024]	5.5 [0.217]

NHB SERIES SWING TYPE

180° Open Specification

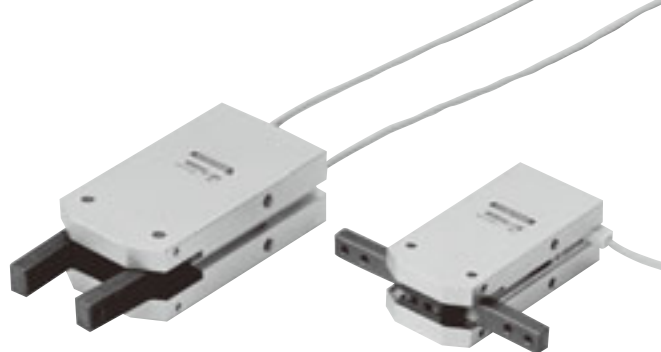

Symbol

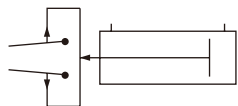

Double Acting Type

Specifications

● Double acting swing type

Basic model		NHBDSL-12	NHBDSL-16	NHBDSL-20	NHBDSL-25
Item					
Cylinder bore size	mm [in.]	12 [0.472]	16 [0.630]	20 [0.787]	25 [0.984]
Operation type		Double acting type			
Media		Air			
Operating pressure range	MPa [psi.]	0.2~0.7 [29~102]			
Proof pressure	MPa [psi.]	1.0 [145]			
Operating temperature range	°C [°F]	0~60 [32~140]			
Maximum operating frequency	cycle/min	100			
Lubrication	Cylinder portion	Not required			
	Lever portion	Required (Apply grease to the sliding portion)			
Theoretical gripping moment (M) ^{Note}	N · cm [in · lbf]	47P [0.0287P]	128P [0.0781P]	231P [0.1410P]	525P [0.3204P]
Maximum grip point length	mm [in.]	40 [1.57]	80 [3.15]	100 [3.94]	60 [2.36]
Effective gripping force (F) ^{Note}	N [lbf.]	$F = M/L \times 9.0$ [$F = M/L \times 0.9$]			
Lever open/closed angles		-10° ~ +180°	-6° ~ +180°		-10° ~ +180°
Port size		M3×0.5	M5×0.8		
Mass	g [oz.]	55 [1.94] (65 [2.29])	146 [5.15] (165 [5.82])	277 [9.77] (303 [10.69])	427 [15.06] (478 [16.86])

Note: F: Effective gripping force (value when levers are parallel), L: Grip point length mm [in.], M: Theoretical gripping moment, P: Operating pressure MPa [psi.]. Values of P and L should vary from SI unit to imperial units. For details of the effective gripping force, see the graphs on p. 1389.

Inner Construction

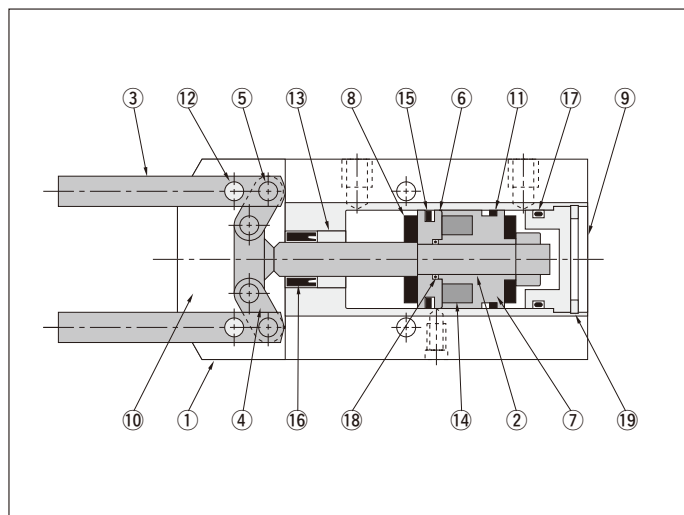

Major Parts and Materials

No.	Parts	Materials
①	Body	Aluminum alloy
②	Piston rod	Carbon steel
③	Lever	Carbon steel
④	Link	Carbon steel
⑤	Press fitting link pin	Carbon tool steel
⑥	Piston	Brass
⑦	Piston holder	Brass
⑧	Cushion rubber	Urethane
⑨	Head cover	Aluminum alloy
⑩	Slide plate	Phosphor bronze
⑪	Wear ring	Plastic
⑫	Fulcrum pin	Carbon tool steel
⑬	Oil impregnated bushing	Oil impregnated copper alloy
⑭	Magnet	Magnet material
⑮	Piston seal	Synthetic rubber (NBR)
⑯	Rod seal	Synthetic rubber (NBR)
⑰	Head seal	Synthetic rubber (NBR)
⑱	O-ring	Synthetic rubber (NBR)
⑲	C-shaped snap ring	Steel

Order Codes

Mounting bracket

No mounting bracket

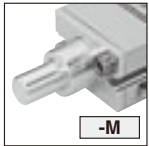
Blank

With mounting bracket

-M

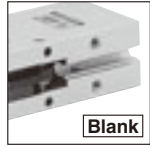
★ Included at shipping

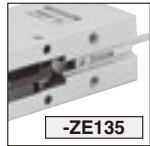
Sensor switch

No sensor switch

Blank

With ZE135

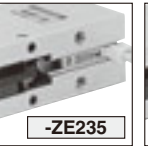
-ZE135

With ZE155

-ZE155

With ZE235

-ZE235

With ZE255

-ZE255

- Solid state type
- With indicator lamp
- DC10~28V
- 2-lead wire
- Horizontal lead wire

- Solid state type
- With indicator lamp
- DC4.5~28V
- 3-lead wire
- Horizontal lead wire

- Solid state type
- With indicator lamp
- DC10~28V
- 2-lead wire
- Vertical lead wire

- Solid state type
- With indicator lamp
- DC4.5~28V
- 3-lead wire
- Vertical lead wire

Lead wire length

A : 1000mm [39in.]
B : 3000mm [118in.]

Number of sensor switches
(for air hands with sensor switches)

● 1 : With 1 sensor switch
● 2 : With 2 sensor switches

★ Included at shipping

Additional Parts (To be ordered separately)

Mounting bracket



- For ϕ 12 [0.472in.] — NHB-M12
- For ϕ 16 [0.630in.] — NHB-M16
- For ϕ 20 [0.787in.] — NHB-M20
- For ϕ 25 [0.984in.] — NHB-M25

	Basic model	Cylinder bore size				
Double acting type	NHBDSL	-12 -16 -20 -25	-M	-ZE135 -ZE155 -ZE235 -ZE255	A B	1 2

Dimensions of Swing Type 180° Open Specification (mm)

NHBDSL-12
NHBDSL-16
NHBDSL-20
NHBDSL-25

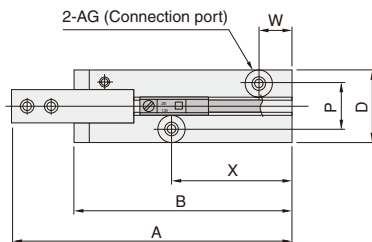

※ Drawings show ϕ 20.

 NHBDSL Cylinder bore size Note

Note: Not including NHBDSL-12 and NHBDSL-25.

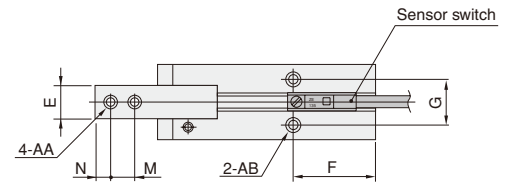
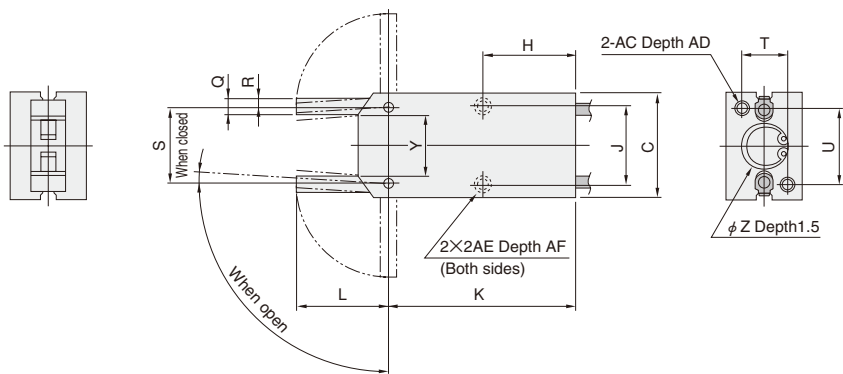

● For mounting bracket (-M), see p.1438.

Model	Code	A	B	C	D	E	F	G	H	J	K	L	M	N	P	Q
NHBDSL-12		59	47	27	16	6.0 ⁰ _{-0.03}	22	10	30	18	39	20	6	3	10	4.5
NHBDSL-16		87.5	69	34	22	8.0 ⁰ _{-0.03}	25	14	30	24	59	28.5	8	4	12	5.5
NHBDSL-20		103	81	45	26	10.0 ⁰ _{-0.03}	28	16	35	30	69.5	33.5	10	4	13	7
NHBDSL-25		114.5	88	52	32	12.0 ⁰ _{-0.03}	45	18	43	36	73.5	41	12	5	18 ^{+0.1}	10

R	S	T	U	W	X	Y	Z	AA	AB	AC	AD	AE	AF	AG	When open	When closed
2.5	20	10	20	6.5	23	16	ϕ 13 ^{+0.05} ₀	M3×0.5	M3×0.5	M3×0.5	5	M4×0.7	5 (ϕ 3.2 Thru.)	M3×0.5	90° ^{±2.5}	-3° ^{±1.5}
3	24	14	26	10.5	38	19	ϕ 17 ^{+0.05} ₀	M3×0.5	M4×0.7	M4×0.7	7	M4×0.7	7 (ϕ 3.2 Thru.)	M5×0.8		
4	30	16	35	11.5	43.5	24	ϕ 21 ^{+0.05} ₀	M4×0.7	M5×0.8	M5×0.8	8	M5×0.8	8 (ϕ 4.2 Thru.)	M5×0.8		
6	37	20	40	14	43	29	ϕ 26 ^{+0.05} ₀	M5×0.8	M6×1	M6×1	—	M6×1	10 (ϕ 5.2 Thru.)	M5×0.8		

WHDP SERIES RACK OPERATION PARALLEL TYPE

Wide Type Air Hands, Double Acting Type

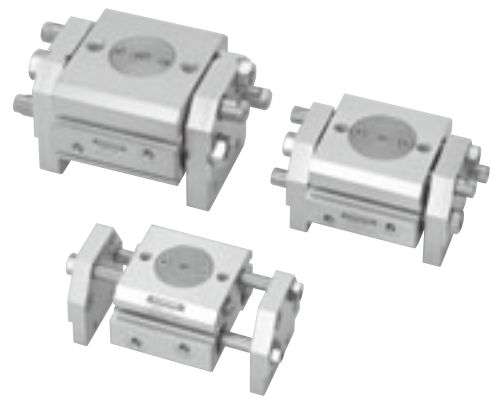

Specifications

● Double acting rack operation parallel type

Basic model		WHDP-12	WHDP-16	WHDP-20	WHDP-25
Item					
Cylinder bore size	mm [in.]	12 [0.472]	16 [0.630]	20 [0.787]	25 [0.984]
Operation type		Double acting type			
Media		Air			
Operating pressure range	MPa [psi.]	0.2~0.7 [29~102]			
Proof pressure	MPa [psi.]	1.05 [152]			
Operating temperature range	°C [°F]	0~60 [32~140]			
Maximum operating frequency	cycle/min	120			
Lubrication		Not required			
Effective gripping force (F) ^{Note}	N [lbf.]	24 [5.4]	48 [10.8]	82 [18.4]	132 [29.7]
Lever open/closed stroke	mm [in.]	24 [0.945]	32 [1.260]	40 [1.575]	50 [1.969]
Repeatability	mm [in.]	±0.08 [±0.0031]			
Port size		M5×0.8			
Mass	g [oz.]	230 [8.1]	400 [14.1]	760 [26.8]	1100 [38.8]

Note: Values are obtained when grip point length is 50mm [1.97in.] under operating pressure 0.5 MPa [73psi].
For details of the effective gripping force, see the graphs on p.1391.

Order Codes

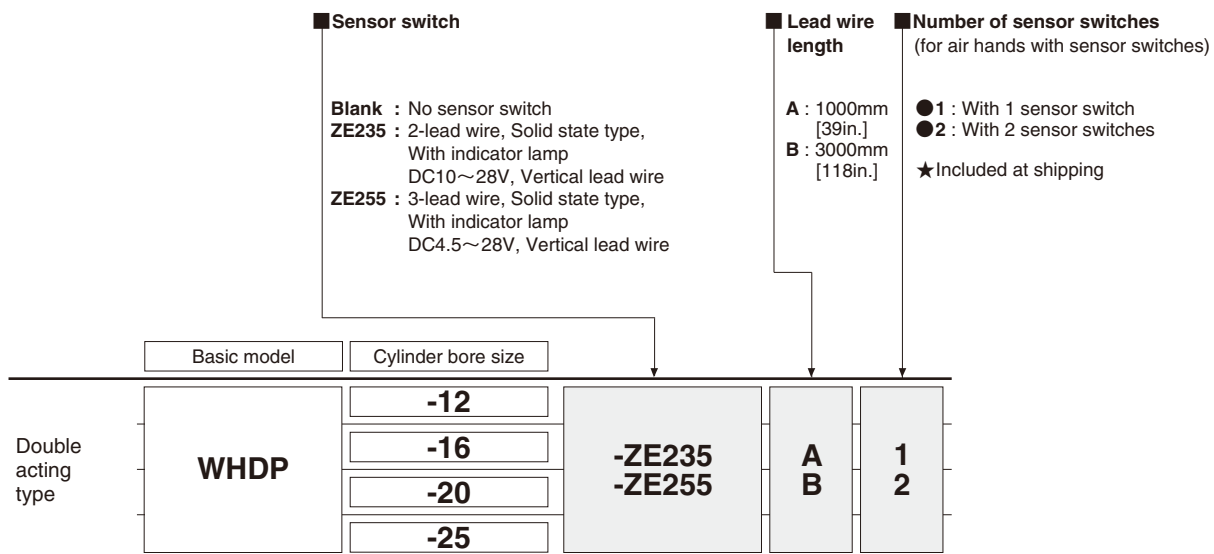

Inner Construction

● Diagrams show double acting type $\phi 12$ [0.472in.].

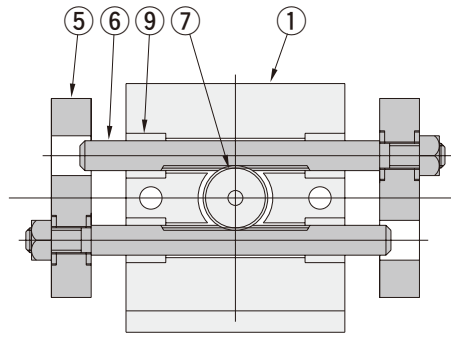

Section A — A'

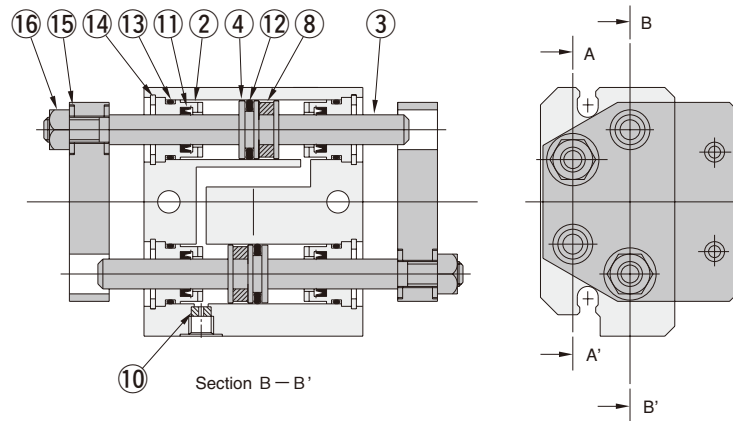

Section B — B'

Major Parts and Materials

No.	Parts	Materials
①	Body	Aluminum alloy
②	Rod cover	Aluminum alloy
③	Piston rod	Stainless steel
④	Piston	Aluminum alloy
⑤	Lever	Aluminum alloy
⑥	Guide rod	Stainless steel
⑦	Pinion	Stainless steel
⑧	Magnet	Plastic magnet

No.	Parts	Materials
⑨	Metal bushing	Bearing copper alloy
⑩	Fixed throttle	Aluminum alloy
⑪	Seal	Synthetic rubber
⑫	Seal	Synthetic rubber
⑬	O-ring	Synthetic rubber
⑭	Snap ring	Carbon tool steel
⑮	Plain washer	Stainless steel
⑯	Hexagon nut	Mild steel

Dimensions of Rack Operation Parallel Type (mm)

WHDP-12

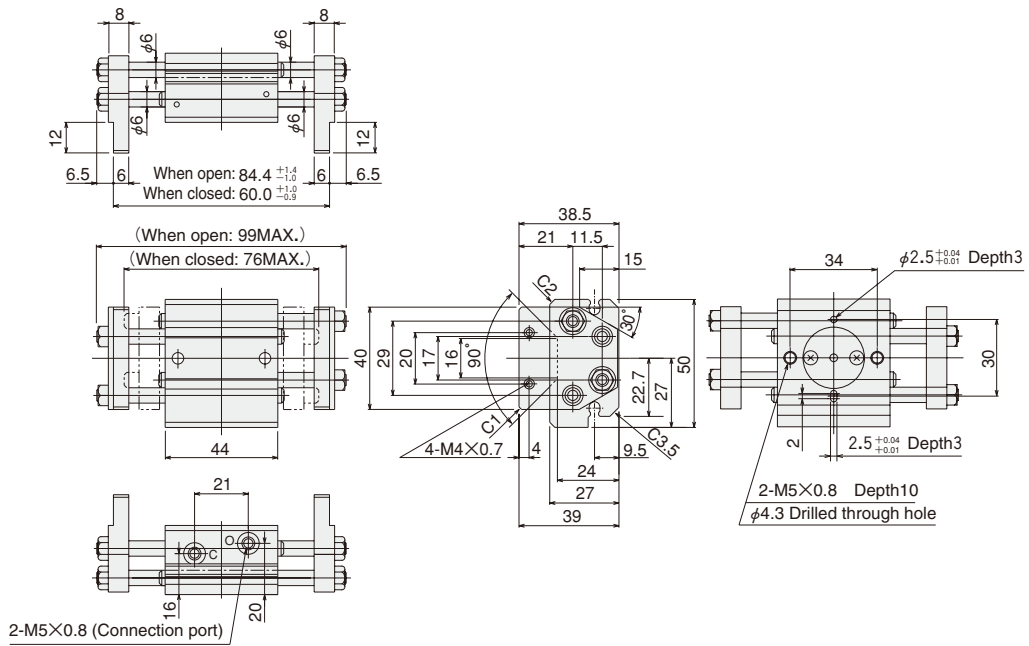

WHDP-16

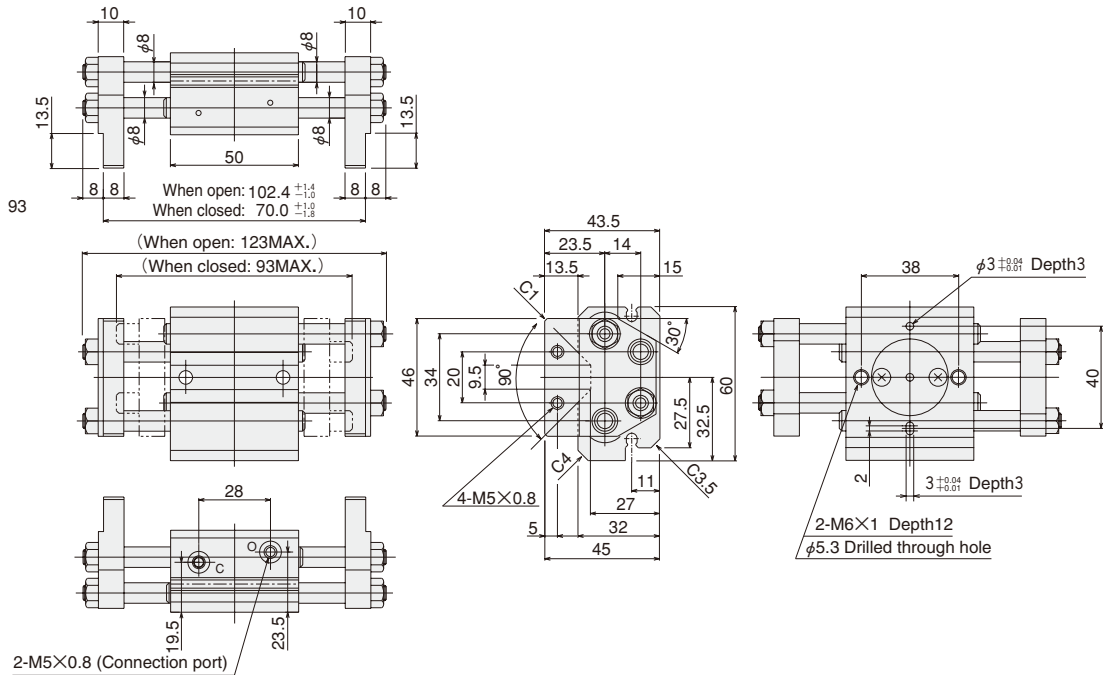

Dimensions of Rack Operation Parallel Type (mm)

WHDP-20

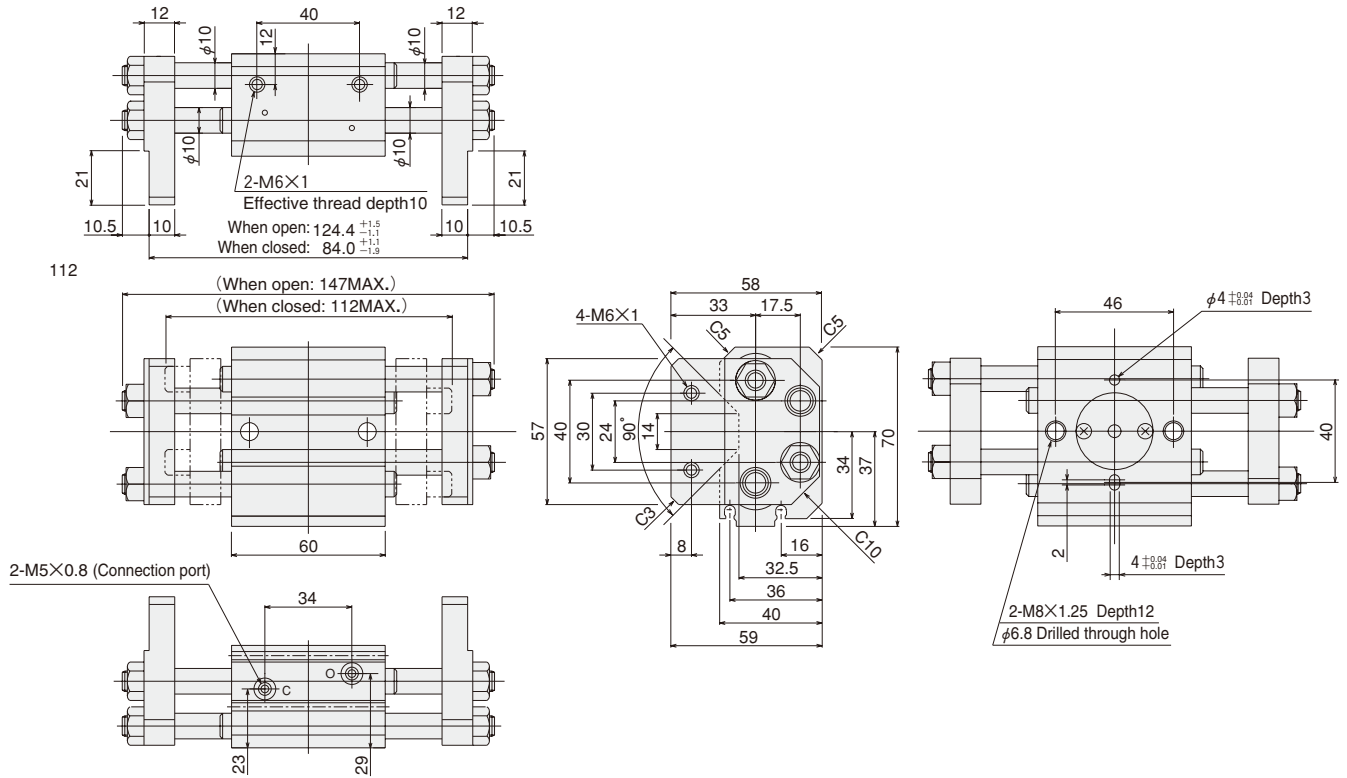

WHDP-25

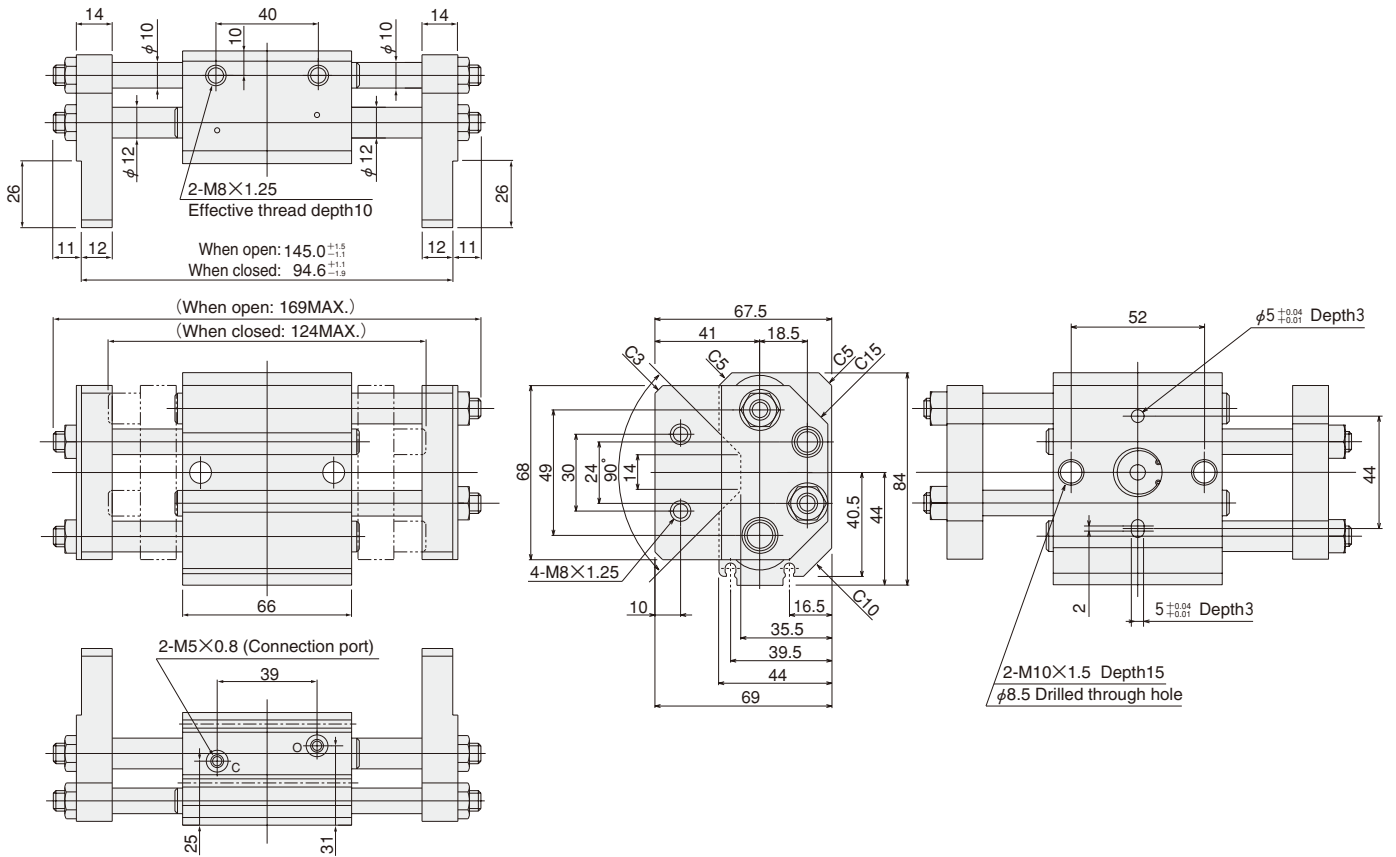

AIR HANDS SERIES

NHB SERIES PARALLEL TYPE

Mechanical Hands Linear Guide Specification Mechanical Hands

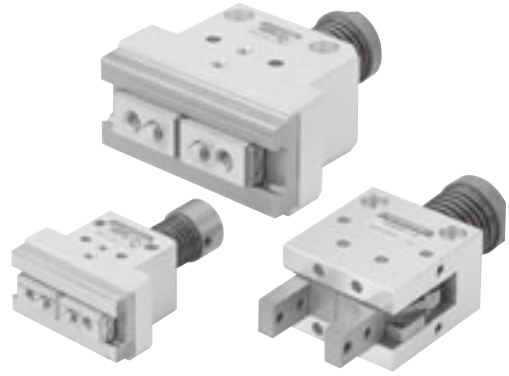

Specifications

● Parallel type mechanical hands

Basic model		NHBMRP-10	NHBMP-10	NHBMRP-16	NHBMP-16	NHBMRP-20	NHBMP-20
Item							
Nominal diameter (NHBDPG equivalent)	mm [in.]	10 [0.394]		16 [0.630]		20 [0.787]	
Operation type		Single acting normally open type	Single acting normally closed type	Single acting normally open type	Single acting normally closed type	Single acting normally open type	Single acting normally closed type
Operation method		Operating by external force type when closed	Operating by external force type when open	Operating by external force type when closed	Operating by external force type when open	Operating by external force type when closed	Operating by external force type when open
Returning method		Compression spring					
Operating temperature range	°C [°F]	0~60 [32~140]					
Maximum operating frequency	cycle/min	100					
Lubrication		Required (Apply grease to the sliding portion)					
Repeatability	mm [in.]	±0.01 [±0.0004]					
Gripping force	N [lbf.]	-L	3.4 [0.76]		4.4 [0.99]		6.5 [1.46]
		-M	4.5 [1.01]		6.4 [1.44]		8.3 [1.87]
Pushing force ^{Note1}	N [lbf.]	-L	23.5 [5.28]		32.3 [7.26]		47.0 [10.57]
		-M	32.3 [7.26]		47.0 [10.57]		58.8 [13.22]
Allowable pushing force	N [lbf.]	50 [11.2]		130 [29.2]		210 [47.2]	
Lever ratio ^{Note2}		1 : 2.1					
Mass	g [oz.]	60 [2.12]		135 [4.76]		245 [8.64]	

Notes: 1. Pushing force refers to the external force required to completely open the lever against the spring force constantly exerted in the closed direction.

2. Lever ratio expresses the "pushing distance : lever open distance (stroke)" where the pushing distance on the rear rod is assumed to be 1.

● Parallel type linear guide specification mechanical hands

Basic model		NHBMPG-8	NHBMPG-10	NHBMPG-16	NHBMPG-20	
Item						
Nominal diameter (NHBDPG equivalent)	mm [in.]	8 [0.315]	10 [0.394]	16 [0.630]	20 [0.787]	
Operation type		Single acting normally closed type				
Operation method		Operating by external force type when open				
Returning method		Compression spring				
Operating temperature range	°C [°F]	0~60 [32~140]				
Maximum operating frequency	cycle/min	100				
Lubrication		Required (Apply grease to the sliding portion)				
Repeatability	mm [in.]	±0.01 [±0.0004]				
Gripping force	N [lbf.]	-L	1.6 [0.36]	3.4 [0.76]	4.4 [0.99]	6.5 [1.46]
		-M	2.6 [0.58]	4.5 [1.01]	6.4 [1.44]	8.3 [1.87]
Pushing force ^{Note1}	N [lbf.]	-L	12.2 [2.74]	19.6 [4.41]	27.4 [6.16]	28.2 [6.34]
		-M	17.2 [3.87]	27.4 [6.16]	39.2 [8.81]	40.7 [9.15]
Allowable pushing force	N [lbf.]	30 [6.7]	50 [11.2]	130 [29.2]	210 [47.2]	
Open/closed stroke	mm [in.]	4.8 [0.189]	6.8 [0.268]	11.2 [0.441]	14.9 [0.587]	
Lever ratio ^{Note2}		1 : 2		1 : 2.2		
Mass	g [oz.]	31 [1.09]	78 [2.75]	156 [5.50]	312 [11.0]	

Notes: 1. Pushing force refers to the external force required to completely open the lever against the spring force constantly exerted in the closed direction.

2. Lever ratio expresses the "pushing distance : lever open distance (stroke)" where the pushing distance on the rear rod is assumed to be 1.

Inner Construction

● Parallel type mechanical hands

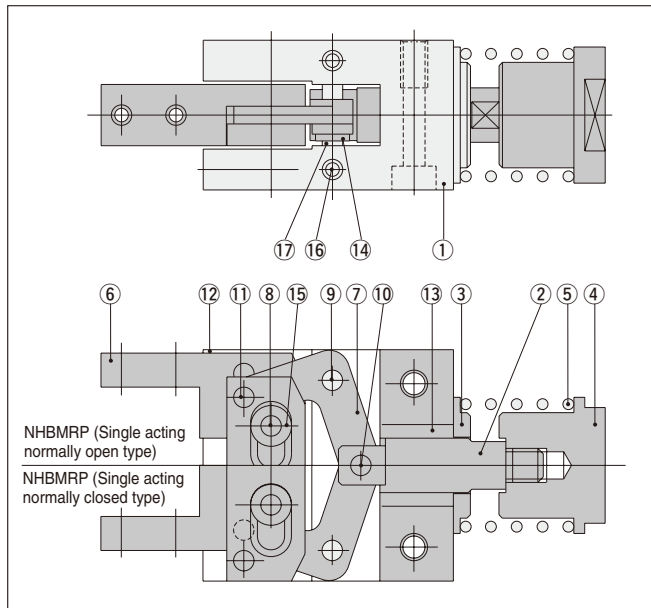

● Parallel type linear guide specification mechanical hands

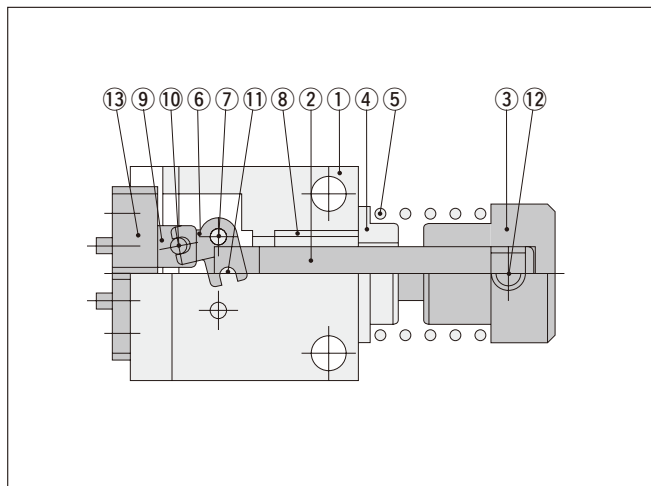

Major Parts and Materials

● Parallel type mechanical hands

No.	Parts	Materials
①	Body	Aluminum alloy
②	Piston rod	Stainless steel
③	Holder	Aluminum alloy
④	Holder	Aluminum alloy
⑤	Spring	Steel wire
⑥	Lever	Steel
⑦	Action lever	Steel
⑧	Fulcrum pin	Steel
⑨	Fulcrum pin	Steel
⑩	Press fit pin	Steel
⑪	Press fit pin	Steel
⑫	Slide plate	Steel
⑬	Metal	—
⑭	Ring	Steel
⑮	Ring	Brass
⑯	Hexagon socket setscrew	Steel
⑰	Snap ring	Steel

● Parallel type linear guide specification mechanical hands

No.	Parts	Materials
①	Body	Aluminum alloy
②	Piston rod	Stainless steel
③	Holder	Steel
④	Holder	Aluminum alloy
⑤	Spring	Steel wire
⑥	Action lever	Steel
⑦	Fulcrum pin	Steel
⑧	Metal	—
⑨	Knuckle	Stainless steel
⑩	Roller	Steel
⑪	Roller	Steel
⑫	Hexagon socket setscrew	Steel
⑬	Bearing	—

Order Codes

● Parallel type mechanical hands

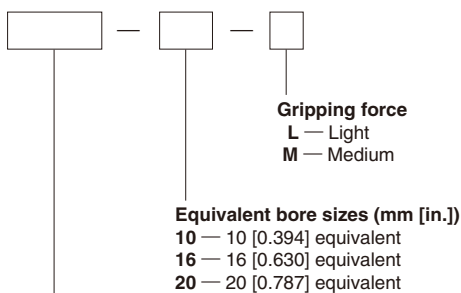

Basic model
NHBMP — Air hand NHB series Parallel type
 Mechanical hand Single acting normally closed type
NHBMRP — Air hand NHB series Parallel type
 Mechanical hand Single acting normally open type

● Parallel type linear guide specification mechanical hands

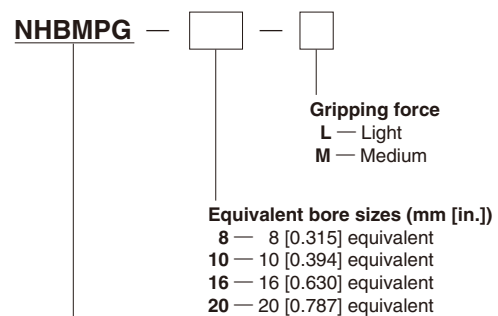

Air hand NHB series
 Linear guide specification mechanical hand, single acting
 normally closed type

Caution: The sensor switch cannot be used with the mechanical hand.

NHBMP-10
NHBMRP-10

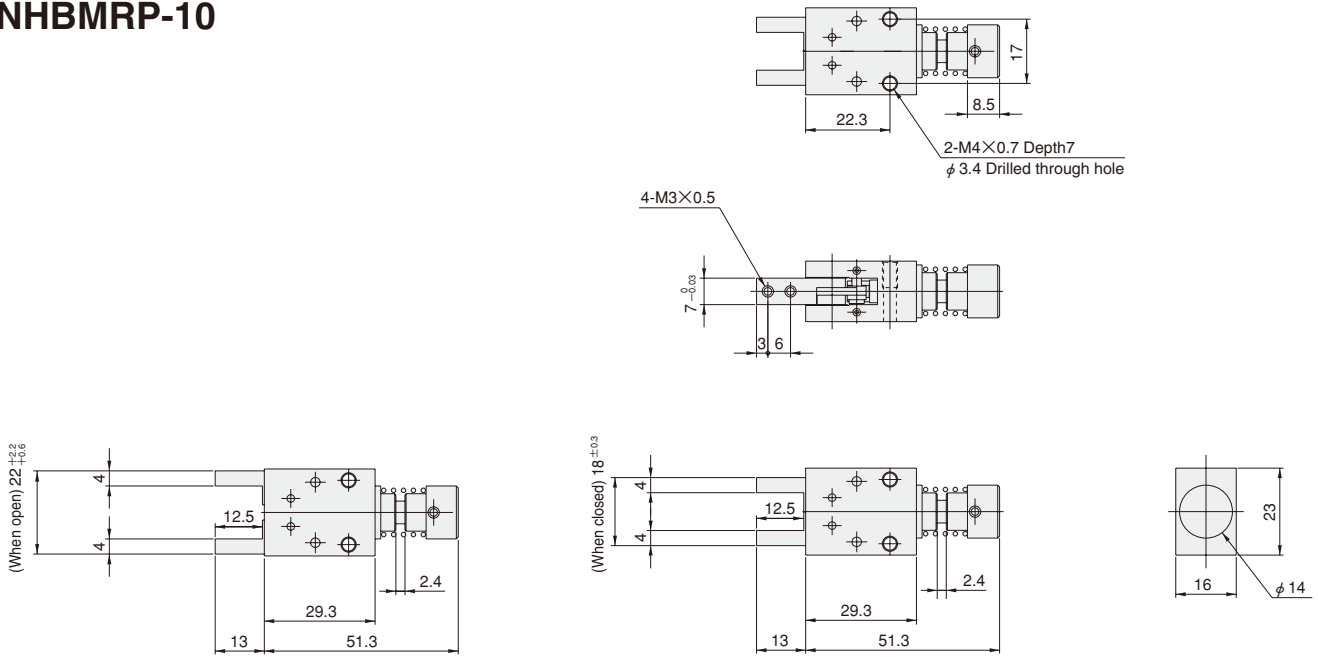

NHBMRP-10 (Single acting normally open type)

NHBMP-10 (Single acting normally closed type)

NHBMP-16
NHBMRP-16

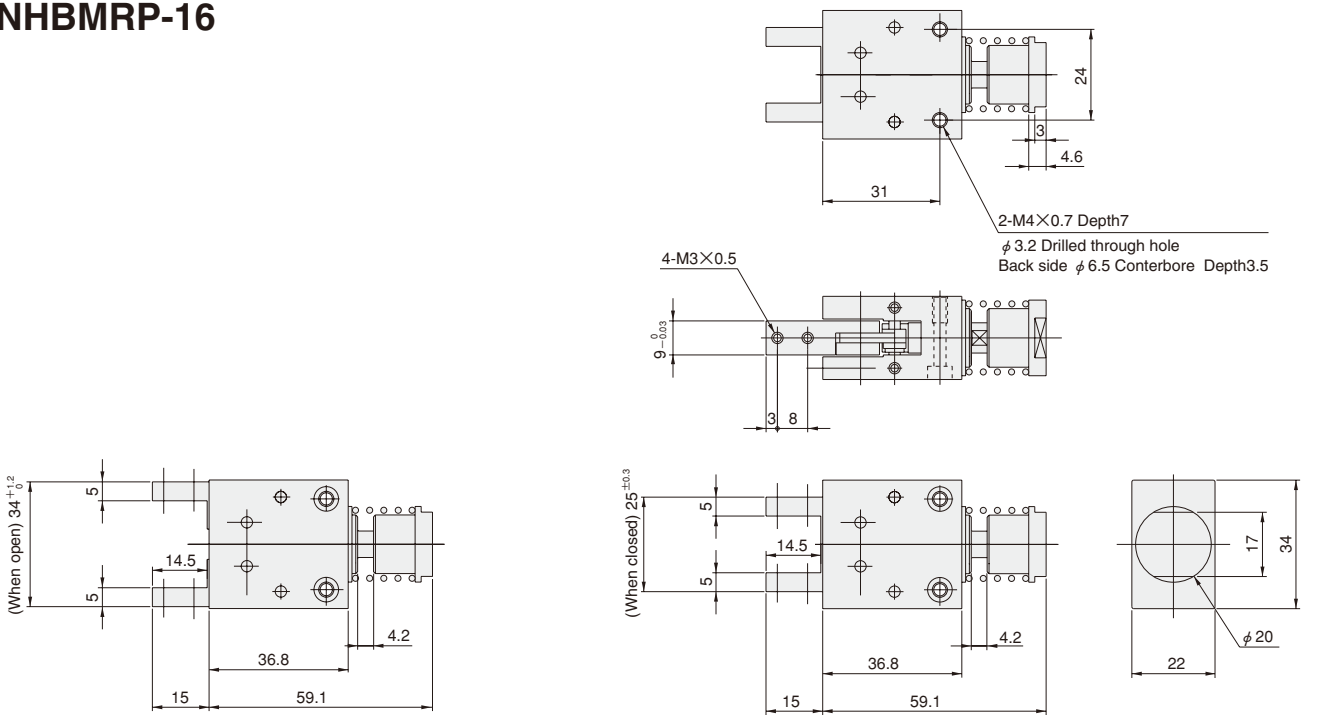

NHBMRP-16 (Single acting normally open type)

NHBMP-16 (Single acting normally closed type)

NHBMP-20
NHBMRP-20

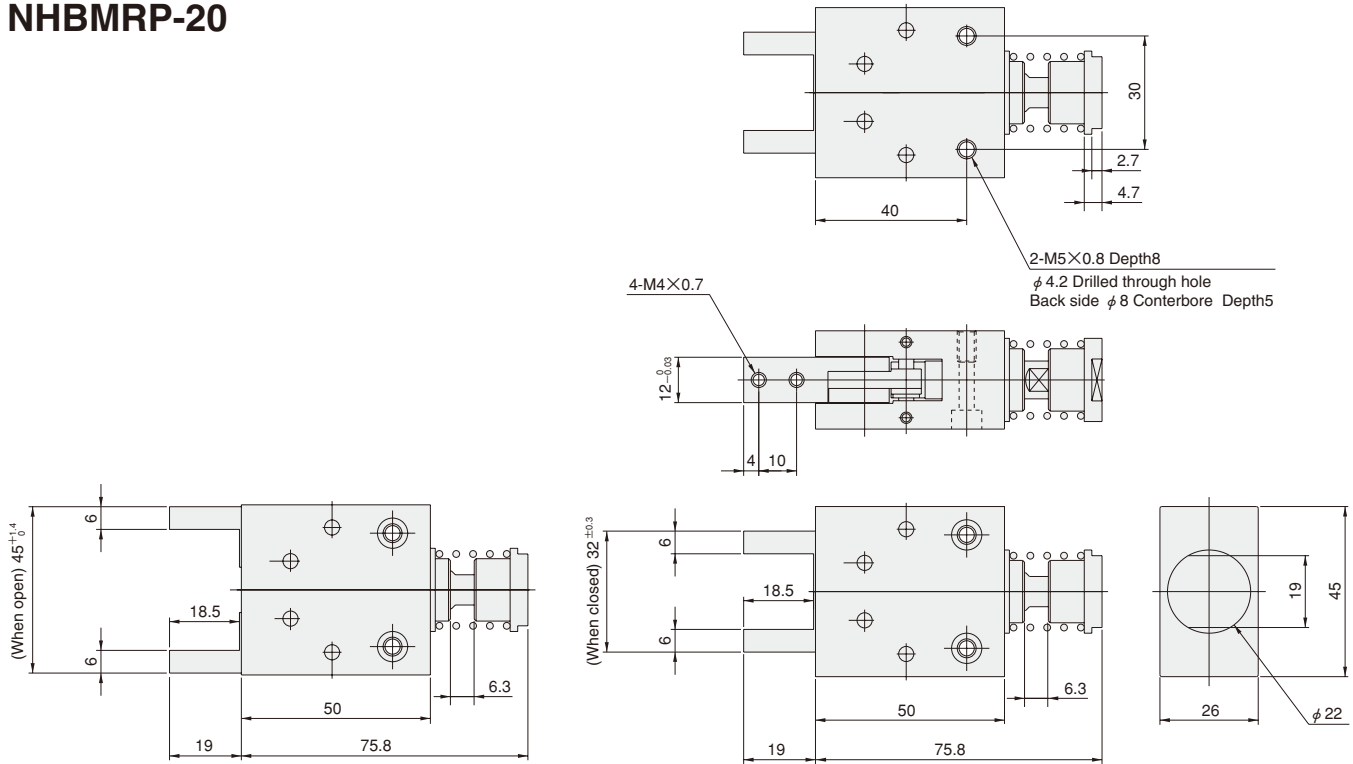

NHBMRP-20 (Single acting normally open type)

NHBMP-20 (Single acting normally closed type)

NHBMPG-8

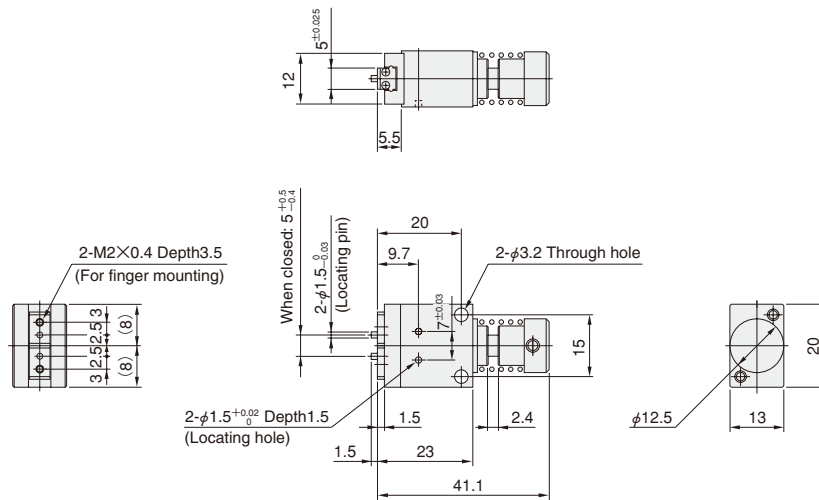

NHBMPG-10

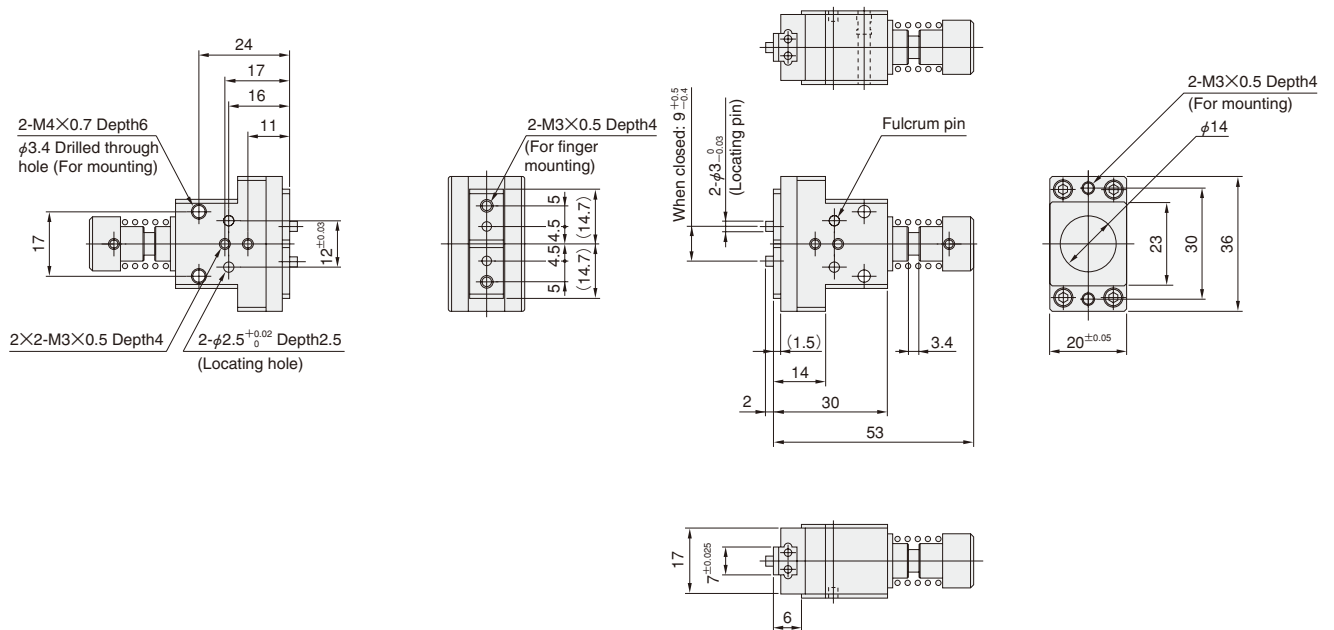

NHBMPG-16

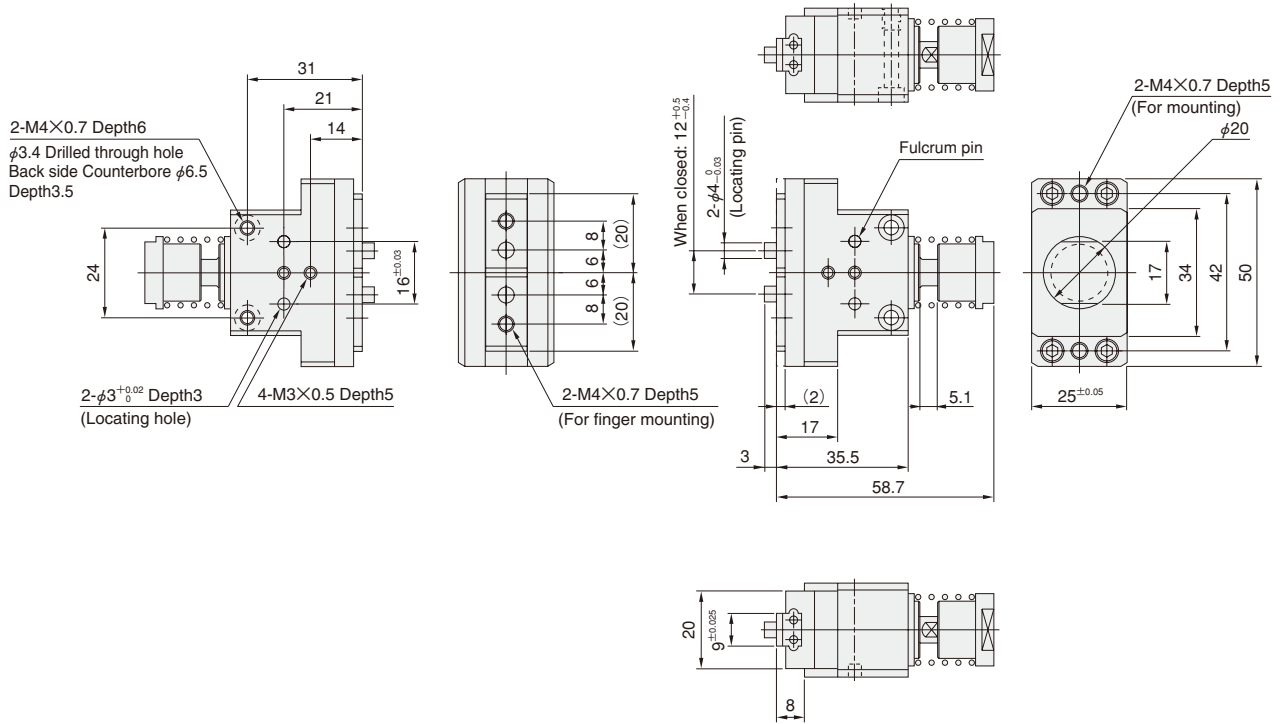

NHBMPG-20

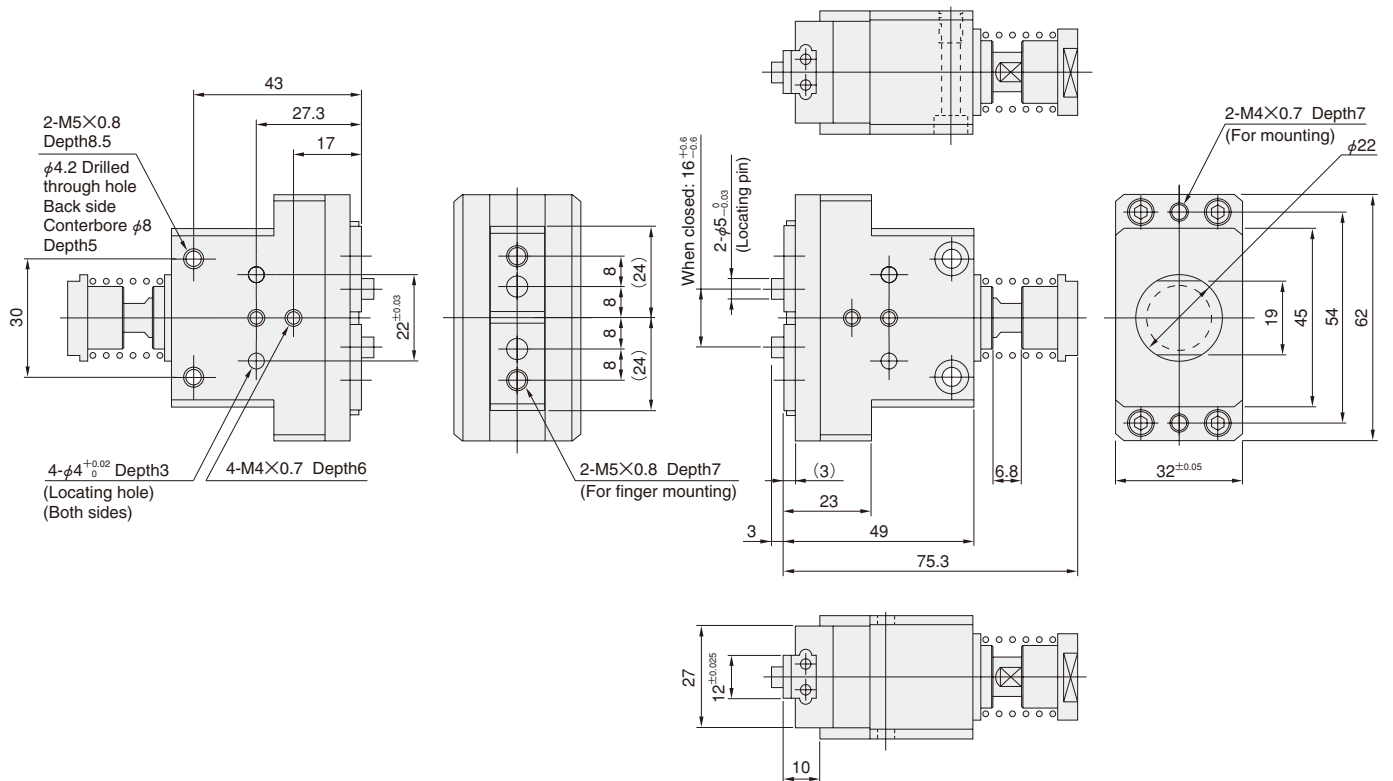

THREE-FINGER TYPE LINEAR GUIDE SPECIFICATION

Mechanical Hands

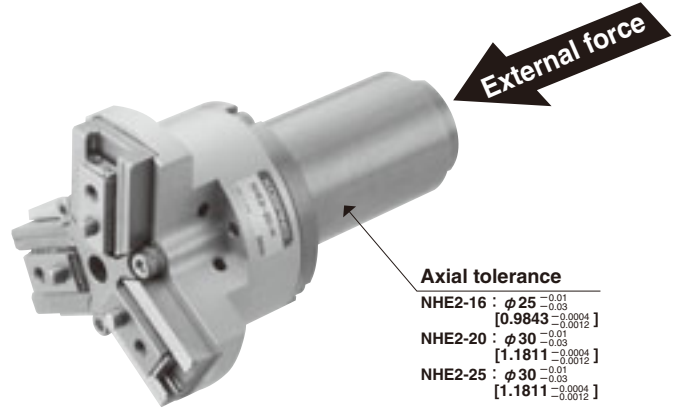

Specifications

Basic model		NHE2-16	NHE2-20	NHE2-25
Nominal diameter	mm [in.]	16 [0.630]	20 [0.787]	25 [0.984]
Open/closed stroke	mm [in.]	6 [0.236]	10 [0.394]	14 [0.551]
Operation type		Single acting normally closed type (external force drive when open)		
Elastic body used		Compression spring		
Operating temperature range	°C [°F]	0~120 [32~248]		
Maximum operating frequency	cycle/min	180		
Lubrication		Required		
Repeatability	mm [in.]	±0.01 [±0.0004]		
Centering accuracy	mm [in.]	±0.05 [±0.0020]		
Spring gripping force (when open)	-L	3 [0.7]	7 [1.6]	12 [2.7]
	-M	5 [1.1]	12 [2.7]	18 [4.0]
	-H	7 [1.6]	17 [3.8]	26 [5.8]
Pushing force ^{Note 1}	-L	14 [3.1]	38 [8.5]	66 [14.8]
	-M	24 [5.4]	64 [14.4]	95 [21.4]
	-H	34 [7.6]	88 [19.8]	138 [31.0]
Allowable pushing force	N [lbf.]	50 [11.2]	130 [29.2]	210 [47.2]
Lever ratio ^{Note 2}		1 : 1.1		
Mass	g [oz.]	300 [10.6]	560 [19.8]	870 [30.7]

Notes: 1. Pushing force refers to the external force required to completely open the lever against the spring force constantly exerted in the closed direction.
2. Lever ratio expresses the "pushing distance : lever open distance (stroke)" where the pushing distance on the rear rod is assumed to be 1.

Inner Construction

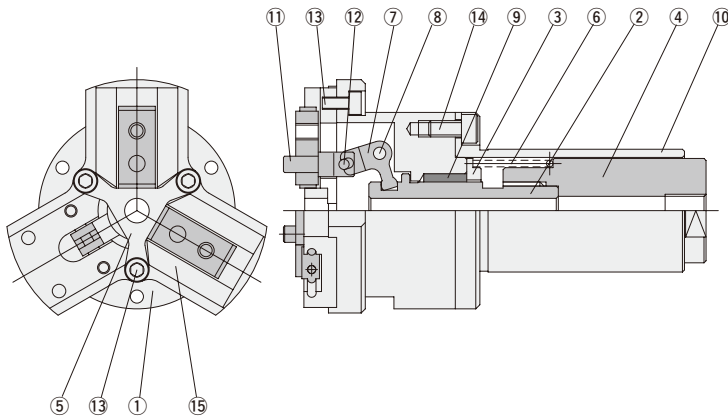

Major Parts and Materials

No.	Parts	Materials
①	Body	Aluminum alloy
②	Piston rod	Stainless steel
③	Holder	Aluminum alloy
④	Holder	Stainless steel
⑤	Holder cover	Stainless steel
⑥	Spring	Spring steel
⑦	Action lever	Carbon steel
⑧	Fulcrum pin	Carbon steel
⑨	Metal	Sintered oil impregnated bushing
⑩	Case	Stainless steel
⑪	Knuckle	Stainless steel
⑫	Roller	Carbon steel
⑬	Hexagon socket head bolt	Stainless steel
⑭	Hexagon socket head bolt	Stainless steel
⑮	Bearing	Stainless steel

Order Codes

NHE 2 - -

Three-finger hands series
Mechanical hand high precision specification

Nominal diameter
16 : $\phi 16\text{mm}$ [0.630in.]
20 : $\phi 20\text{mm}$ [0.787in.]
25 : $\phi 25\text{mm}$ [0.984in.]

Spring gripping force
L : Weak
M : Medium
H : Strong

NHE2-16-□

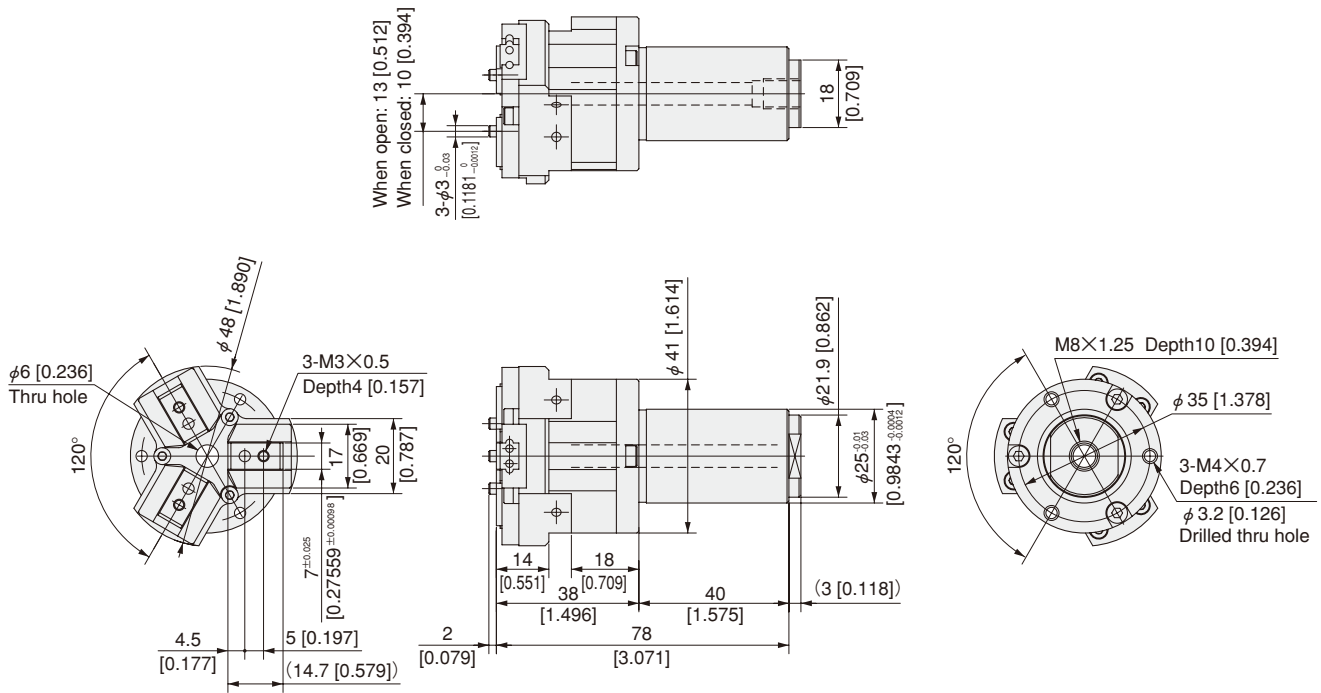

NHE2-20-□

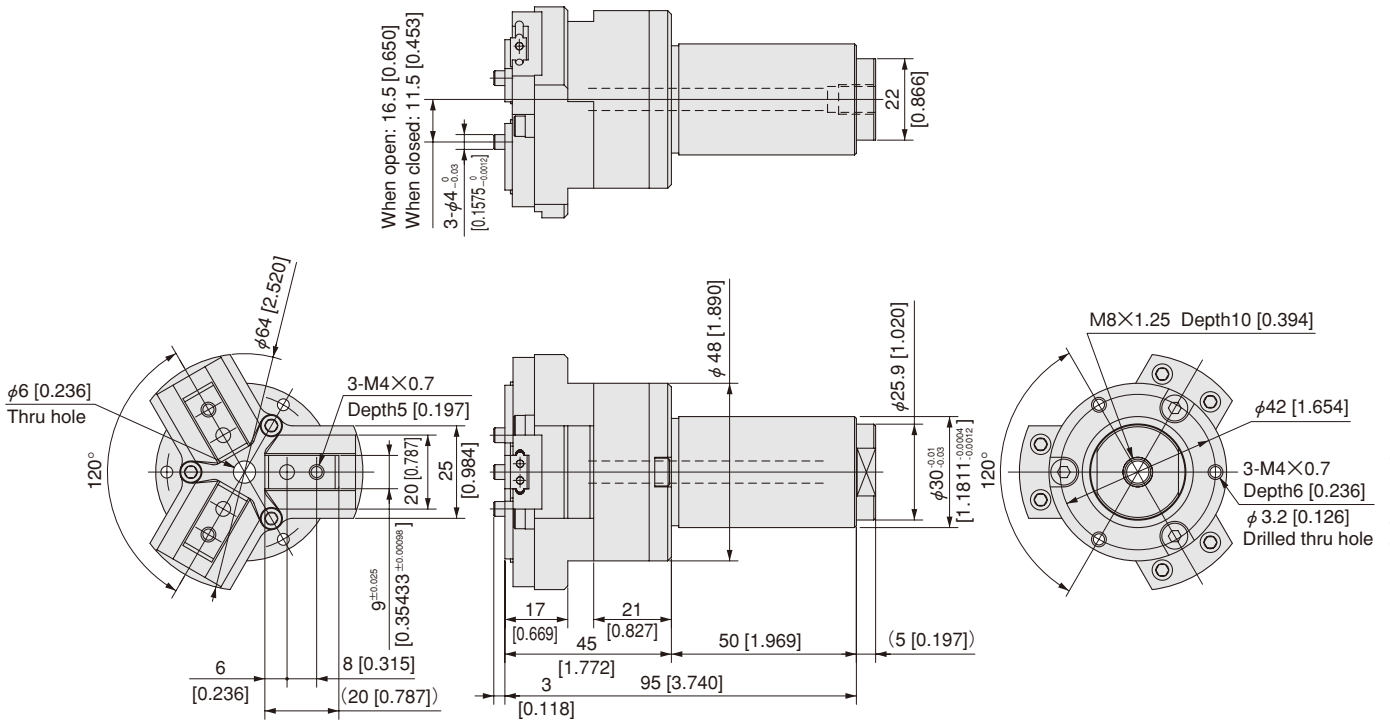

NHE2-25-□

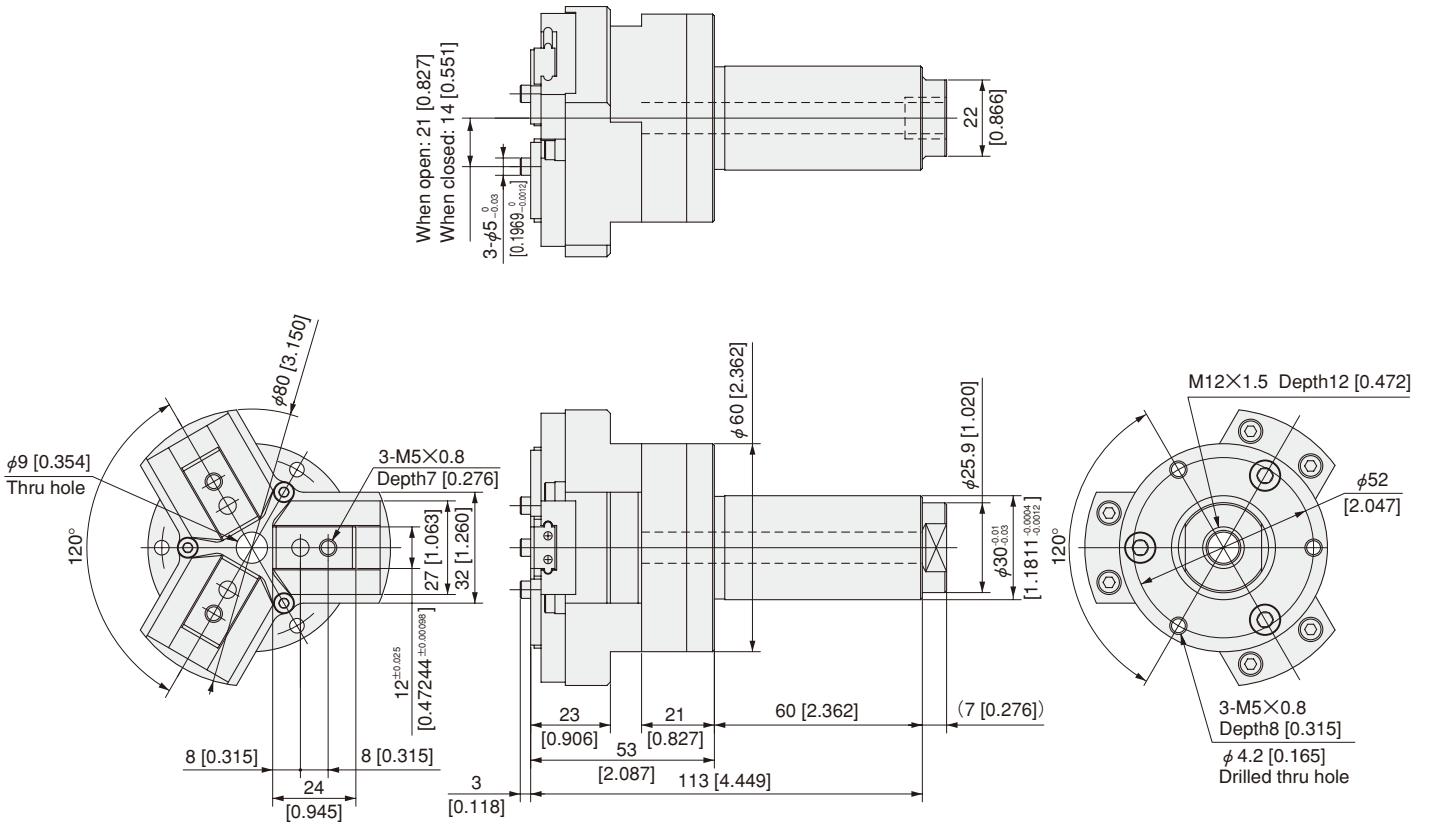

Application Example

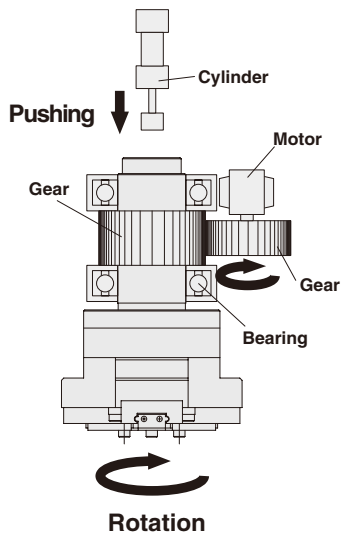

SENSOR SWITCHES

Solid State Type

Symbol

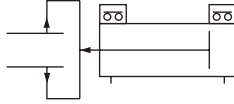

Order Codes

● Sensor switch only

● NHC1 series



Lead wire length
A — 1000mm [39in.]
B — 3000mm [118in.]

Sensor switch

- ZE135** — Solid state type 2-lead wire with indicator lamp DC10~28V Horizontal lead wire
- ZE235** — Solid state type 2-lead wire with indicator lamp DC10~28V Vertical lead wire
- ZE155** — Solid state type 3-lead wire with indicator lamp DC4.5~28V Horizontal lead wire
- ZE255** — Solid state type 3-lead wire with indicator lamp DC4.5~28V Vertical lead wire

● NHB series



Lead wire length
A — 1000mm [39in.]
B — 3000mm [118in.]

Sensor switch

- ZE135** — Solid state type 2-lead wire
- ZE235** — Solid state type 2-lead wire
- ZE155** — Solid state type 3-lead wire
- ZE255** — Solid state type 3-lead wire

● WHDP series



Lead wire length
A — 1000mm [39in.]
B — 3000mm [118in.]

Sensor switch

- ZE235** — Solid state type 2-lead wire
- ZE255** — Solid state type 3-lead wire

● Three-finger type linear guide specification (air hands)



Lead wire length
A — 1000mm [39in.]
B — 3000mm [118in.]

Sensor switch

- ZE135** — Solid state type 2-lead wire with indicator lamp DC10~28V Horizontal lead wire
- ZE235** — Solid state type 2-lead wire with indicator lamp DC10~28V Vertical lead wire
- ZE155** — Solid state type 3-lead wire with indicator lamp DC4.5~28V Horizontal lead wire
- ZE255** — Solid state type 3-lead wire with indicator lamp DC4.5~28V Vertical lead wire

Caution: Sensor switch cannot be mounted on the mechanical hands.

● For details of sensor switches, see p.1544.

Sensor Switch Operating Range and Response Differential

● Open/closed stroke differential (Open/closed angle differential)

The stroke differential (angle differential) between the point where the lever on one side moves and turns the switch ON and the point where the switch is turned OFF as the lever travels in the opposite direction.

● Operating position repeatability

When the lever on one side moves in the same direction, operating position repeatability is defined as the range of the deviation of the position where the switch is turned ON or turned OFF.

Parallel type linear guide specification

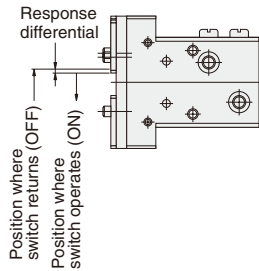

Parallel type

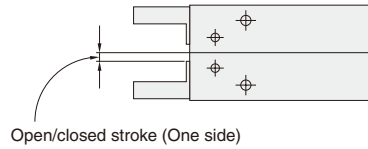

Swing type

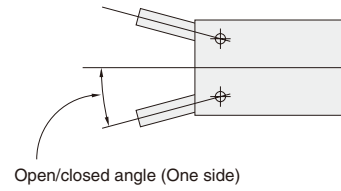

Rack operation parallel type

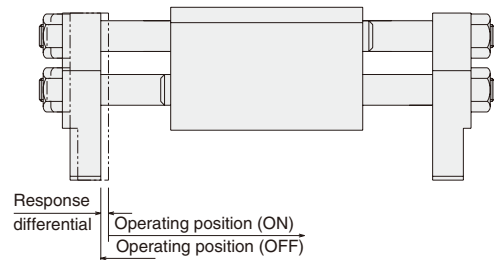

● NHC1 series

mm [in.]

Model	Open/closed stroke differential	Operating position repeatability
NHC1D-10	0.2 [0.008]	0.1 [0.004]
NHC1D-16	0.2 [0.008]	0.1 [0.004]
NHC1D-20	0.2 [0.008]	0.1 [0.004]
NHC1D-25	0.2 [0.008]	0.1 [0.004]

Remark: The above table shows reference values.

● Parallel type

mm [in.]

Model	Open/closed stroke differential	Operating position repeatability
NHB□PA-6	0.5 [0.020]	0.2 [0.008]
NHB□P□-10	0.5 [0.020]	0.2 [0.008]
NHB□P□-16	0.6 [0.024]	0.2 [0.008]
NHB□P□-20	0.6 [0.024]	0.2 [0.008]
NHB□P□-25	0.6 [0.024]	0.2 [0.008]

Remark: The above table shows reference values.

● Swing type

Model	Open/closed angle differential	Operating position repeatability
NHB□S-8	3.0°	1.0°
NHB□S-10	2.0°	1.0°
NHB□S-16	1.5°	0.6°
NHB□S-20	1.5°	0.5°
NHB□S-25	1.0°	0.5°

Remark: The above table shows reference values.

● Parallel type linear guide specification (with rubber cover)

mm [in.]

Model	Open/closed stroke differential	Operating position repeatability
NHB□PG(J)-8	0.5 [0.020]	0.2 [0.008]
NHB□PG(J)-10	0.5 [0.020]	0.2 [0.008]
NHB□PG(J)-16	0.8 [0.031]	0.2 [0.008]
NHB□PG(J)-20	0.8 [0.031]	0.2 [0.008]
NHBDPG-32	0.8 [0.031]	0.2 [0.008]

Remark: The above table shows reference values.

● Swing type 180° open specification

Model	Open/closed angle differential	Operating position repeatability
NHBDSL-12	1.5°	0.5°
NHBDSL-16	1.0°	0.25° (one side)
NHBDSL-20	2.0°	0.2° (one side)
NHBDSL-25	3.0°	0.5°

Remark: The above table shows reference values.

● Rack operation parallel type

mm [in.]

Model	Open/closed stroke differential	Operating position repeatability
WHDP-12	0.6 [0.024]	0.2 [0.008]
WHDP-16	0.6 [0.024]	0.2 [0.008]
WHDP-20	0.5 [0.020]	0.2 [0.008]
WHDP-25	0.5 [0.020]	0.2 [0.008]

Remark: The above table shows reference values.

● Swing type high precision, 180° open specification

Model	Open/closed angle differential	Operating position repeatability
NHBDSL-12	3.0°	0.5°
NHBDSL-16	1.5°	0.5°
NHBDSL-20	2.5°	0.5°

Remark: The above table shows reference values.

● Three-finger type linear guide specification (air hands)

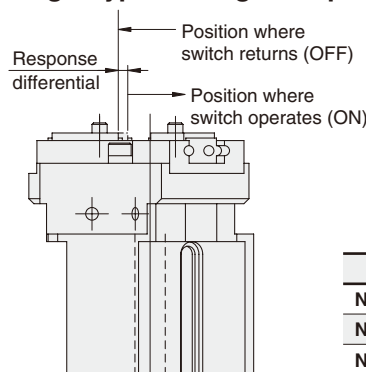

mm [in.]

Model	Maximum response differential
NHE1D-16	0.5 [0.020]
NHE1D-20	0.6 [0.024]
NHE1D-25	0.5 [0.020]

Mounting Sensor Switch

● NHB series

Tighten the mounting screw after the sensor switch is inserted in the switch mounting groove in the direction of the arrow in the diagram and move to the proper location. Tightening torque of the mounting screw is $0.1 \sim 0.2\text{N} \cdot \text{m}$ [$0.9 \sim 1.8\text{in} \cdot \text{lbf}$].

Caution: Care must be exercised that the sensor switch cannot be inserted into the switch mounting groove from the diagram's top direction.

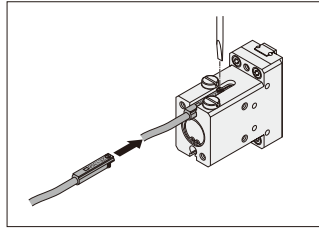

Caution: NHC1 series
NHB□PG(Y, L, J) series
CS-NHBDPG series
NHB□PA series
NHB□S-8
NHBDSLГ series
(Except NHB□PG-32 and NHB□PA-6)
Care must be exercised that a sensor switch cannot be mounted when the body is installed by using thru holes, as shown in the diagram to the right.

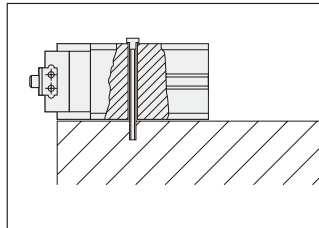

Caution: NHB□PA-25
When using a sensor switch on the lever open side, select the vertical lead wire type ZE235 or ZE255, and mount it in the facing shown in the illustration to the right.

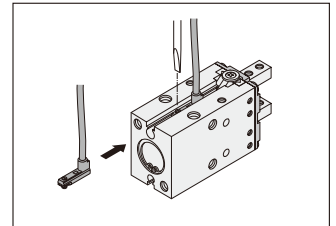

● WHDP series

Tighten the mounting screw after the sensor switch is inserted in the switch mounting groove in the direction of the arrow in the diagram below and move to the proper location. Tightening torque of the mounting screw is $0.1 \sim 0.2\text{N} \cdot \text{m}$ [$0.9 \sim 1.8\text{in} \cdot \text{lbf}$].

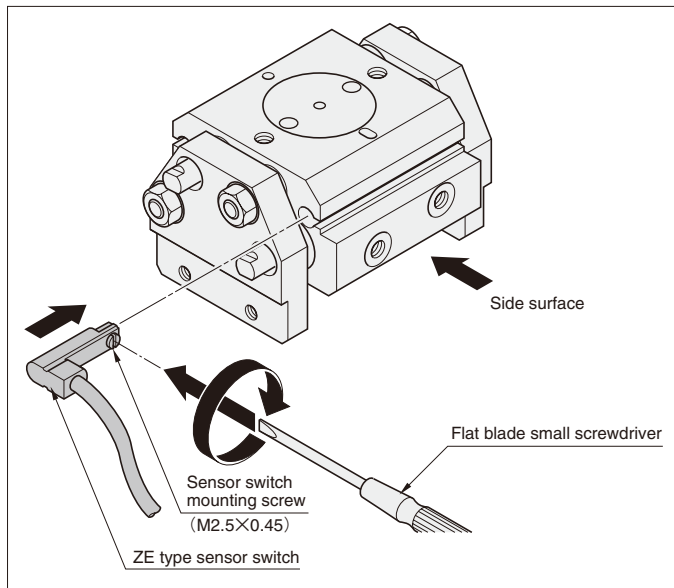

Caution: Care must be exercised that the sensor switch cannot be inserted into the switch mounting groove from the diagram's side surface direction.

● Three-finger type linear guide specification (air hands)

Insert the switch into the switch mounting groove. After setting in the mounting position, use a flat blade small screwdriver to tighten the switch mounting screw. Set the tightening torque to about $0.1 \sim 0.2\text{N} \cdot \text{m}$ [$0.9 \sim 1.8\text{in} \cdot \text{lbf}$]. Be sure to mount the sensor switch so that the side showing the model marking surface faces up.

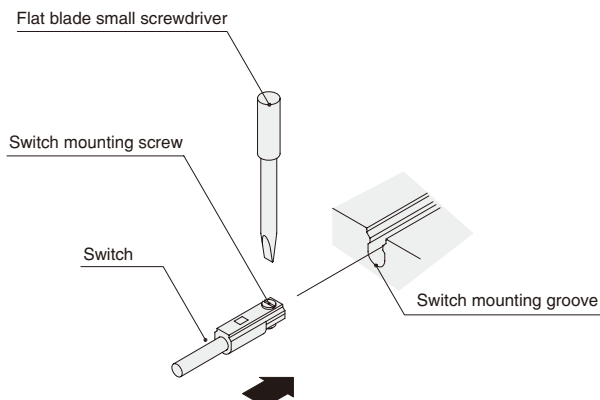

Mounting Sensor Switch

● For swing type (Mount the sensor switch so that the model marking surface faces up.)

《For inside gripping》

- 1) Confirm the levers are completely open.
- 2) Push the switch into the groove on the body in the direction of the arrow.
- 3) By moving the sensor switch in the direction of the arrow, the lamp turns ON, and by moving it further, the lamp turns OFF.
- 4) By moving back the sensor switch in the direction of the arrow (opposite direction), the lamp turns ON, and it should be secured by the sensor switch mounting screw after moving it about 0.3 mm [0.012in.] further.

1) Confirm workpiece is inside gripped one.

《For outside gripping》

- 1) Confirm the levers are completely closed.
- 2) Push the switch into the groove on the body in the direction of the arrow.
- 3) By moving the switch in the direction of the arrow, the lamp turns ON.
- 4) Secure the sensor switch by the mounting screw after moving it about 0.3 mm [0.012in.] further in the direction of the arrow from where the lamp turned ON in step 3).

1) Confirm workpiece is outside gripped one.

Remark: Step 1) shows the location where you want to confirm the switch turns ON. Install and adjust it in accordance with step 1) ~ 4) above.

● For parallel type (Mount the sensor switch so that the model marking surface faces up.)

《For inside gripping》

● For NHBDP□, NHBRP□

- 1) Confirm the levers are completely open.
- 2) Push the switch into the groove on the body in the direction of the arrow.
- 3) By moving the switch in the direction of the arrow, the lamp turns ON.
- 4) Secure the sensor switch by the mounting screw after moving it about 0.3 mm [0.012in.] further in the direction of the arrow from where the lamp turned ON in step 3).

1) Confirm workpiece is inside gripped one.

《For outside gripping》

● For NHBPA□, NHBRPA□

- 1) Confirm the levers are completely closed.
- 2) Push the switch into the groove on the body in the direction of the arrow.
- 3) By moving the sensor switch in the direction of the arrow, the lamp turns ON, and by moving it further, the lamp turns OFF.
- 4) By moving back the sensor switch in the direction of the arrow (opposite direction), the lamp turns ON, and it should be secured by the mounting screw after moving it about 0.3 mm [0.012in.] further.

1) Confirm workpiece is outside gripped one.

Remark: Step 1) shows the location where you want to confirm the switch turns ON. Install and adjust it in accordance with step 1) ~ 4) above.

● For parallel type linear guide specification (with rubber cover) (Mount the sensor switch so that the model marking surface faces up.)

《For inside gripping》

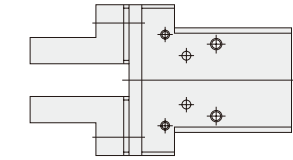

- 1) Confirm the levers are completely open.

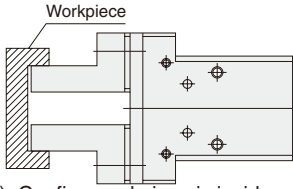

- 1) Confirm workpiece is inside gripped one.

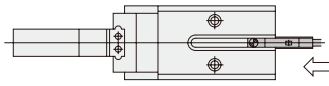

- 2) Insert the switch into the groove on the body in the direction of the arrow.

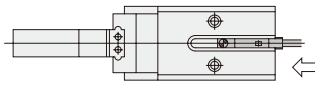

- 3) By moving the sensor switch in the direction of the arrow, the lamp turns ON, and by moving it further, the lamp turns OFF.

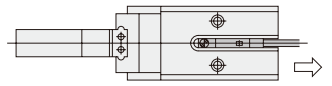

- 4) By moving back the sensor switch in the direction of the arrow (opposite direction), the lamp turns ON, and it should be secured by the sensor switch mounting screw after moving it about 0.3 mm [0.012in.] further.

《For outside gripping》

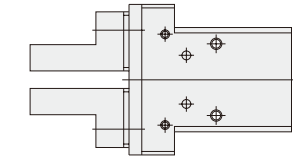

- 1) Confirm the levers are completely closed.

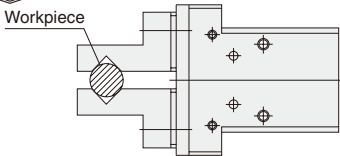

- 1) Confirm workpiece is outside gripped one.

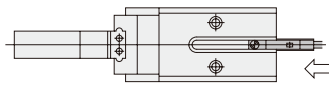

- 2) Insert the switch into the groove on the body in the direction of the arrow.

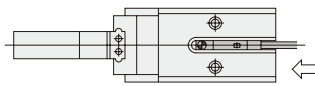

- 3) By moving the switch in the direction of the arrow, the lamp turns ON.

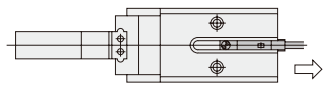

- 4) Secure the sensor switch by the mounting screw after moving it about 0.3 mm [0.012in.] further in the direction of the arrow from where the lamp turned ON in step 3).

Remark: Step 1) shows the location where you want to confirm the switch turns ON. Install and adjust it in accordance with step 1) ~ 4) above.

