



CAD drawing data catalog
is available.



KOGANEI

VALVES GENERAL CATALOG

SOLENOID VALVES 430, 630, 830 SERIES INDEX

Features	725
Basic Models and Configuration	727
Operating Principles	728
430 Series	
Specifications	729
Solenoid Valve Order Codes	731
Collective Wiring Manifold Order Codes	732
Individual Wiring Manifold Order Codes	733
Operating Principles, Major Parts and Materials	734
Dimensions of Solenoid Valve	735
Dimensions of Collective Wiring Manifold	737
Dimensions of Individual Wiring Manifold	739
630 Series	
Specifications	741
Solenoid Valve Order Codes	743
Collective Wiring Manifold Order Codes	744
Individual Wiring Manifold Order Codes	745
Operating Principles, Major Parts and Materials	746
Dimensions of Solenoid Valve	747
Dimensions of Collective Wiring Manifold	749
Dimensions of Individual Wiring Manifold	751
830 Series	
Specifications	753
Solenoid Valve Order Codes	755
Operating Principles, Major Parts and Materials	756
Dimensions of Solenoid Valve	757
Made to Order	759
Handling Instructions and Precautions	761

SOLENOID VALVES 430, 630, 830 SERIES



Caution

Before use, be sure to read the "Safety Precautions" on p. 31.

Pilot type solenoid valves

Solenoid Valves 430, 630, 830 Series

Compact Design

Clean lines due to a compact body, and the lead wires connecting to the terminal block on the sub-base or manifold enable collective wiring for simplified wiring work. A design that fits well with compact units.

Quick Installation and Removal of Valves

A simple plug-in wiring system is used for connections between a solenoid valve and its sub-base, and solenoid valves and a manifold base. Valves can be replaced without disturbing wiring or piping.

Safe Wiring

Bridge diodes are used for the DC24V specification internal circuits. As with AC types, wiring can be performed without concern for polarity.

Non-Neutral Structure

Uses a non-neutral structure to eliminate unstable operation arisen during flow direction changes in large valves.

Long Life

Wear resistance of lip seals is improved for further durability.

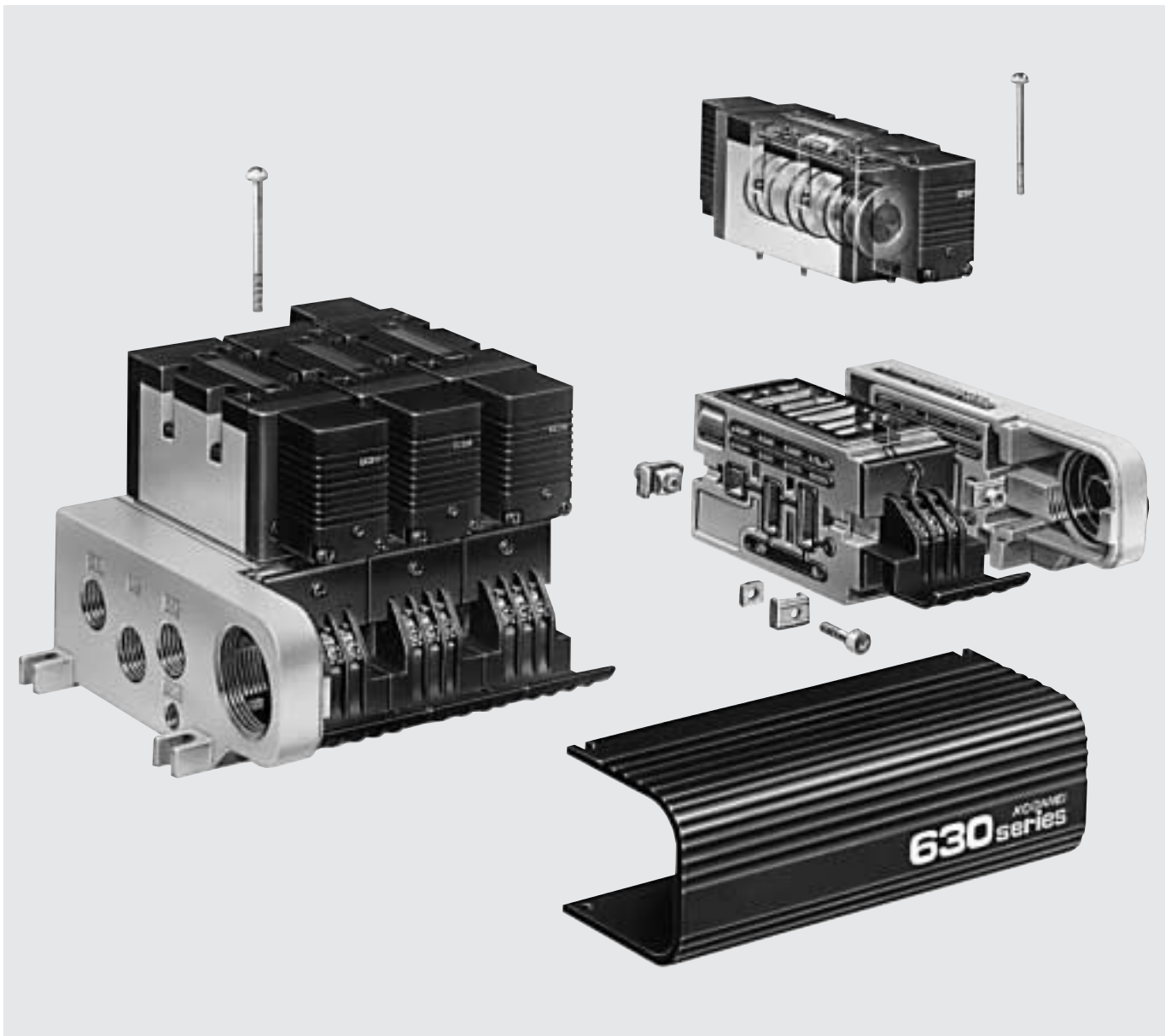

Saves on Wiring (430, 630 series only)

Comes with multi-connector system for collective electrical wiring, or with rational and compatible D-sub connector. Both types include pre-wired common systems to save time in wiring work.

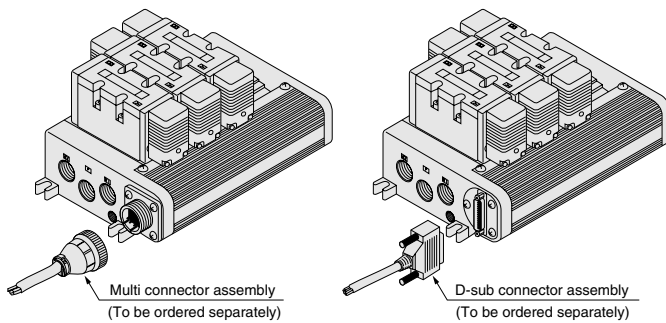

Easy Increase or Decrease of Manifold Units (430, 630 series only)

Since the manifold base is structurally independent from solenoid valves, increase or decrease of units is simple. It is also possible to stock the manifold bases as a single unit. Use of port isolators enables the supply of 2 different pressures on a single manifold.

Conforming Serial Transmission Systems

(430 series only)

Greatly reduces manhours required for wiring, and achieves cost reduction considering all factors in a pneumatic control system through prevention of wrong wiring, offering easier maintenance, etc.

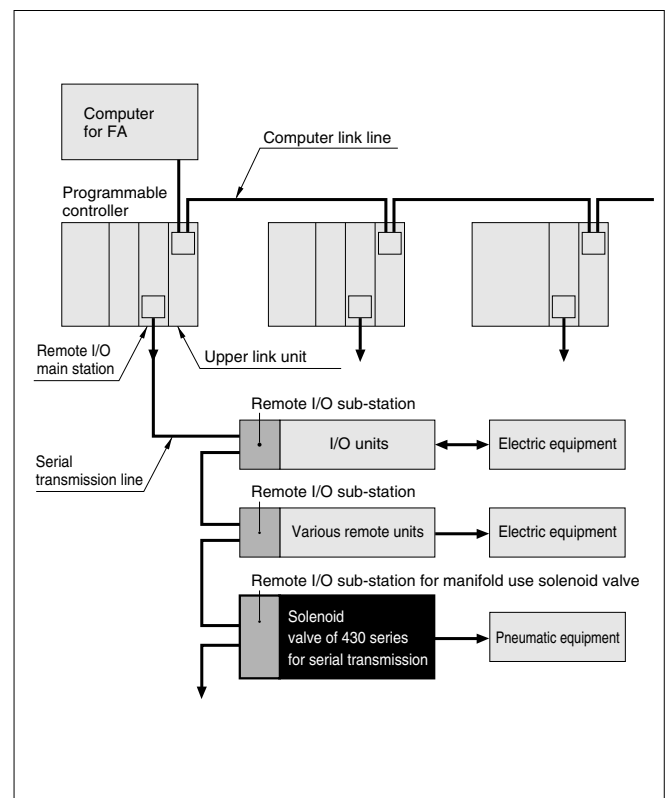

SOLENOID VALVES 430, 630, 830 SERIES

Individual Wiring Manifold

(430, 630 series only)

Individual wiring is in each station. Comes with grommet terminal, conduit terminal and DIN connector. Select the choice of the wiring type.

Bottom Piping (made to order)

Depending on the installation requirements, piping direction can be selected from either the side or bottom surface.

External Pilot (made to order)

Offers stable switching from low to high pressure (0~0.9MPa {0~9.2kgf/cm²} [0~131psi.]).

Solenoid valves 430 series

- 5-port, 2-, 3-position
- Effective area
 - 2-position type : 40mm²/35mm² [Cv : 2.2/1.9]
 - 3-position type : 35mm²/30mm² [Cv : 1.9/1.7]
- Applicable cylinder bore sizes :
 - φ 50 [1.969in.] ~ φ 125 [4.921in.]

Manifold

A type (all ports) manifold



430M

Sub-base

5-port, 2-position
single solenoid



430-4E1

5-port, 2-position
double solenoid



430-4E2

5-port, 3-position
double solenoid



433-4E2

Solenoid valves 630 series

- 5-port, 2-, 3-position
- Effective area
 - 2-position type : 60mm²/55mm² [Cv : 3.3/3.1]
 - 3-position type : 50mm²/45mm² [Cv : 2.8/2.5]
- Applicable cylinder bore sizes :
 - φ 100 [3.937in.] ~ φ 180 [7.087in.]

Manifold

A type (all ports) manifold



630M

Sub-base

5-port, 2-position
single solenoid



630-4E1

5-port, 2-position
double solenoid



630-4E2

5-port, 3-position
double solenoid



633-4E2

Solenoid valves 830 series

- 5-port, 2-, 3-position
- Effective area
 - 2-position type : 120mm²/100mm² [Cv : 6.7/5.6]
 - 3-position type : 120mm²/100mm² [Cv : 6.7/5.6]
- Applicable cylinder bore sizes :
 - φ 125 [4.921in.] ~ φ 300 [11.811in.]

Sub-base

5-port, 2-position
single solenoid



830-4E1

5-port, 2-position
double solenoid



830-4E2

5-port, 3-position
double solenoid



833-4E2

Operating Principles ● The operating principles below are for the 630 series.

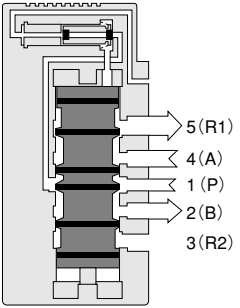
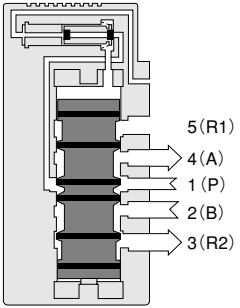
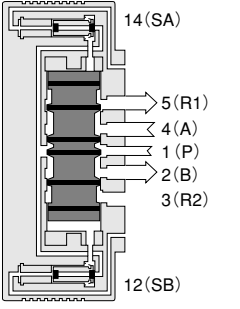
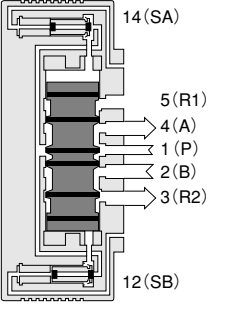
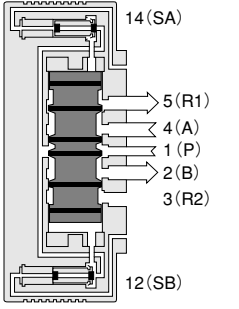
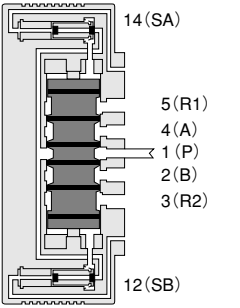
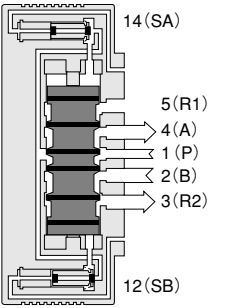
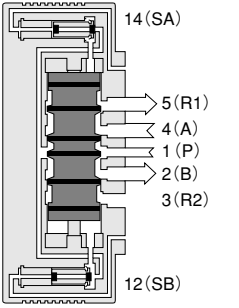
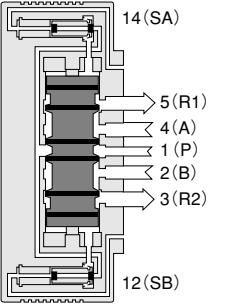
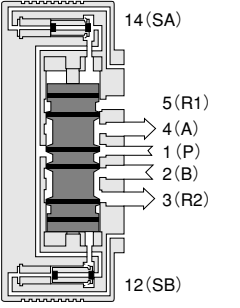
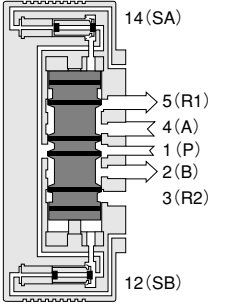
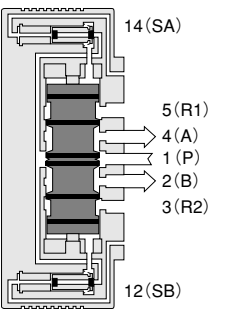
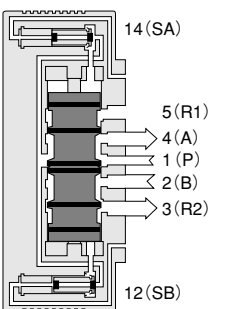
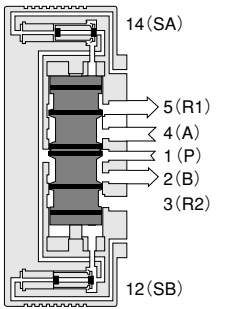
Energized state		Solenoid OFF		Solenoid ON					
Basic model		Solenoid 14(SA) OFF		Solenoid 12(SB) OFF		Solenoid 14(SA) ON		Solenoid 12(SB) ON	
2-position	5-port single solenoid								
	5-port double solenoid	(De-energized condition after energizing solenoid SB) 							
3-position	5-port Closed center								
	5-port Exhaust center								
	5-port Pressure center								

SOLENOID VALVES 430, 630, 830 SERIES

SOLENOID VALVES

430 SERIES

Basic Models and Valve Functions

Basic model	430-4E1	430-4E2	433-4E2
Item			
Number of positions	2 positions		3 positions
Number of ports	5 ports		
Valve function	—	—	Closed center (standard) Exhaust center (optional) Pressure center (optional)

Remark: For optional specifications and order codes, see p.731~733.

Specifications

Basic model	430-4E1	430-4E2	433-4E2
Media	Air		
Operation type	Pilot type		
Effective area ^{Note 1} mm ² [Cv]	Port size ^{Note 2} Rc3/8	40 [2.2]	35 [1.9]
	Rc1/4	35 [1.9]	30 [1.7]
Lubrication	Not required		
Operating pressure range MPa {kgf/cm ² } [psi.]	0.2~0.9 [2.0~9.2] [29~131]	0.1~0.9 [1.0~9.2] [15~131]	0.2~0.9 [2.0~9.2] [29~131]
Proof pressure MPa {kgf/cm ² } [psi.]	1.35 [13.8] [196]		
Response time ^{Note 3} ms	DC24V	25/25 or below	20/20 or below
ON/OFF	AC100V, AC200V	20/30 or below	15/15 or below
Maximum operating frequency	Hz	5	
Minimum time to energize for self holding	ms	—	50
Operating temperature range (atmosphere and media) °C [°F]	5~50 [41~122]		
Shock resistance	m/s ² [G]	294 [30]	
Mounting direction	Any		

Notes: 1. For details, see the effective area on p.730.

2. For details, see the port size on p.730.

3. Values when the air pressure is 0.5MPa {5.1kgf/cm²} [73psi.]. The values for **430-4E2** are when switching from the opposite position, and for **433-4E2** are those of closed center, when switching from the neutral valve position.

Solenoid Specifications

Rated voltage	DC24V	AC100V	AC200V
Item			
Operating voltage range	V	21.6~26.4 (24±10%)	90~110 (100±10%)
Rated frequency	Hz	—	50 60
Current (when rated voltage is applied)	Starting	—	68 58
	Energizing	72	42 32
Power consumption	W	1.7	—
Allowable leakage current	mA	4	6
Insulation resistance ^{Note}	MΩ	Over 100	
Color of LED indicator		Red	Yellow
Surge suppression (as standard)		Surge absorption transistor	Varistor

Note: Value at DC500V megger.

Cylinder Operating Speed

430-4E1-263

Maximum operating speed

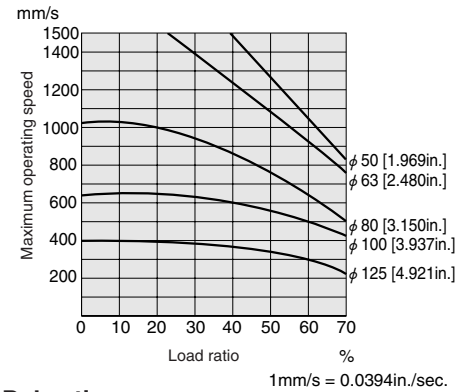

Delay time

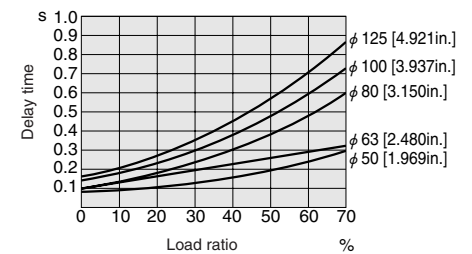

Measurement conditions

- Air pressure: 0.5MPa {5.1kgf/cm²} [73psi.]
- Piping inner diameter and length: φ7.5×1000mm [39in.]
- Fitting: Quick fitting (Model: TS10-03)
- Load ratio = $\frac{\text{Load}}{\text{Cylinder theoretical thrust}} (\%)$
- Cylinder stroke: 300mm [11.8in.]

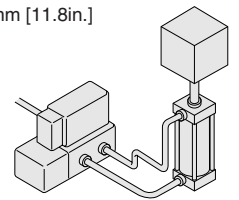

How to obtain cylinder speed

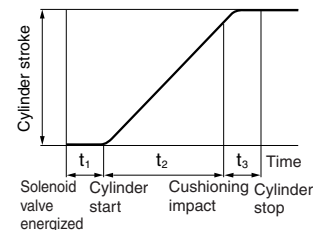

t = Time required for the cylinder to complete 1 stroke

t_1 = Cylinder delay time

t_2 = Time moving at maximum speed

t_3 = Time required for cushioning (about 0.2s)

● Without cushion

$t = t_1 + t_2$

● With cushion

$t = t_1 + t_2 + t_3$

433-4E2-263

Maximum operating speed

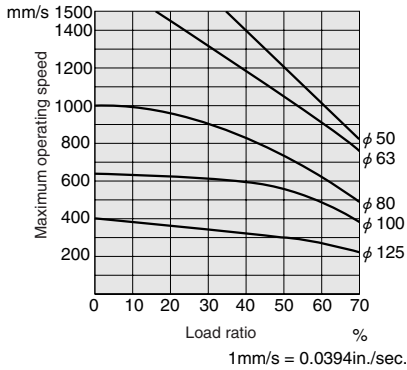

Delay time

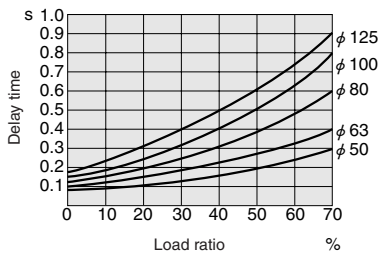

Measurement conditions

- Air pressure: 0.5MPa {5.1kgf/cm²} [73psi.]
- Piping inner diameter and length: φ 7.5×1000mm [39in.]
- Fitting: Quick fitting (Model: TS10-03)
- Load ratio = $\frac{\text{Load}}{\text{Cylinder theoretical thrust}}$ (%)
- Cylinder stroke: 300mm [11.8in.]

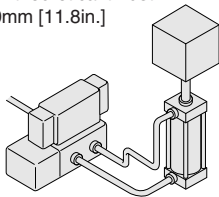

Effective Area [Cv]

Model	Port size	Standard mm ² Note 1	Effective area mm ² Note 2	Fitting size
430-4E1 430-4E2	Rc3/8	40 (2.22)	34 [1.9]	TS 12-03
			30 [1.7]	TS 10-03
			22 [1.2]	TS 8-03
433-4E2	Rc1/4	35 (1.94)	30 [1.7]	TS 12-02
			29 [1.6]	TS 10-02
			22 [1.2]	TS 8-02
433-4E2	Rc3/8	35 (1.94)	29 [1.6]	TS 12-03
			25 [1.4]	TS 10-03
			19 [1.1]	TS 8-03
	Rc1/4	30 (1.66)	26 [1.4]	TS 12-02
			25 [1.4]	TS 10-02
			19 [1.1]	TS 8-02

Notes: 1. Values for single valve unit.
2. Values when fittings are attached on 1(P), 4(A), and 2(B) ports. Fitting size is as shown in the table above.

Solenoid Valve Port Size

Model	Port specification	Sub-base port size
430-4E□-263 433-4E2-263	1 (P)	Rc 3/8
	4 (A), 2 (B)	
	3 (R2), 5 (R1)	
	PR	
430-4E□-262 433-4E2-262	1 (P)	Rc 1/4
	4 (A), 2 (B)	
	3 (R2), 5 (R1)	
	PR	

Manifold Connection Port Size

Manifold model	Port	Piping size
430M□A	1 (P)	Rc 1/2
	4 (A), 2 (B)	Rc 3/8
	3 (R2), 5 (R1)	Rc 1/2
	PR	Rc 1/8

Solenoid Valve Mass g [oz.]

Basic model	Mass
430-4E1	390 [13.76] (800 [28.22])
430-4E2	490 [17.28] (900 [31.75])
433-4E2	540 [19.05] (950 [33.51])

Remark: Figures in parentheses () are the mass with sub-base.

Manifold Mass g [oz.]

Manifold model	Mass calculation of each unit (n=Number of units)	Block-off plate (Model: 430M-BP)
430M□A	(430×n)+830 [(15.17×n)+29.28]	100 [3.53]
430M□AT	(430×n)+630 [(15.17×n)+22.22]	
430M□ASR	(430×n)+2000 [(15.17×n)+70.55]	
430M□ASL		

Flow Rate

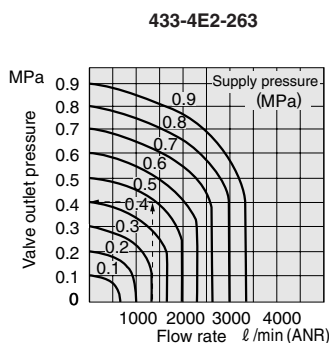
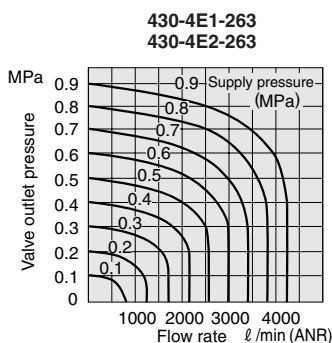

1Mpa = 145psi., 1 l /min = 0.0353ft³/min.

How to read the graph

When the supply pressure is 0.5MPa [73psi.] and the flow rate is 1300 l /min [45.9ft³/min.] (ANR), the valve outlet pressure becomes 0.4MPa [58psi.].

430 Series Solenoid Valve Order Codes



		3-position valve Valve function	Sub-base	Manual override	Wiring type
		Closed center Blank	Port size Rc1/4, side piping -262	Non-locking type Manual override Blank	Grommet type Blank
		Exhaust center -13	Port size Rc3/8, side piping -263	Locking type Manual lever override -84	Conduit type -37
		Pressure center -14	Port size Rc1/4, bottom piping (made to order) -282		DIN connector -39
			Port size Rc3/8, bottom piping (made to order) -283		
			●When ordering single valve units, omit this code from the order code. The single valve unit includes 4 mounting screws and 1 gasket.		
		Basic model			Voltage
Internal pilot sub-base	5-port, 2-position single solenoid	430-4E1		-84	DC24V AC100V AC200V
	5-port, 2-position double solenoid	430-4E2	-262		
	5-port, 3-position double solenoid	433-4E2	-13,-14	-84	
External pilot sub-base (made to order)	5-port, 2-position single solenoid	432-4E1	-282	-84	-37 -39
	5-port, 2-position double solenoid	432-4E2	-283		

For made to order details, see p.759.

Additional Parts (To be ordered separately)

Speed controller

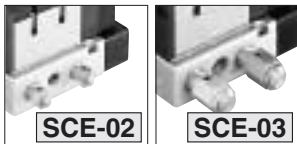

●For Rc1/4

●For Rc3/8

Muffler

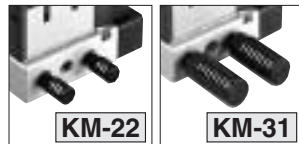

●For Rc1/4

●For Rc3/8

Block-off plate



430 Series Collective Wiring Manifold Order Codes



Wiring type	Serial transmission module	3-position valve Valve function	Manual override	Port isolator
Terminal block Blank	-OR OMRON -MB Mitsubishi Electric -FJ Fuji Electric FA Components & Systems -SP SHARP -MS Matsushita Electric Works -HT Hitachi	Closed center Blank	Non-locking type manual override Blank	Blank : Without port isolator -MSP : For 1(P) port -MSR : For 3(R2), 5(R1) ports -MSD : For 1(P), 3(R2), 5(R1) ports
Multi connector On right side MR On left side ML		Exhaust center -13	Locking type manual lever override -84	
D-sub connector On right side DR On left side DL		Pressure center -14		
Serial transmission module On right side SR On left side SL				

	Manifold model Number of units	Station	Basic model	Voltage
Internal pilot manifold	430M 2 ⋮ 10 A	MR ML DR DL SR SL	-OR -MB -FJ -SP -MS -HT	stn. <input type="checkbox"/> ⋮ stn. <input type="checkbox"/>
External pilot manifold (made to order)	432M B			
			-430-4E1 -430-4E2 -433-4E2 -432-4E1 -432-4E2	-84 -84 -13,-14 -84 -84
				-MSP -MSR -MSD
				DC24V AC100V AC200V

For made to order details, see p.759.

- Maximum 8 units for multi connectors, D-sub connectors, and serial transmission modules.
- A : Side piping
B : Bottom piping (made to order)
- Valve mounting location from the left, with wiring cover on top and the 4(A), 2(B) ports in front (□ : 1~10)
- Specify the valve model for each station.
- Enter -BP when closing a station with a block-off plate without mounting a valve.
- To increase the units in the manifold, order additional manifold units. (For order codes, see p.765.)

- When one of these port isolator order codes is entered to the designated station, the port isolator is installed in the space between the designated station and the station to its right (the side with the larger station number). For details, see the port isolators item on p.765.
Note: The port isolator can be installed to only 1 station on each manifold set.

430 Series Individual Wiring Manifold Order Codes

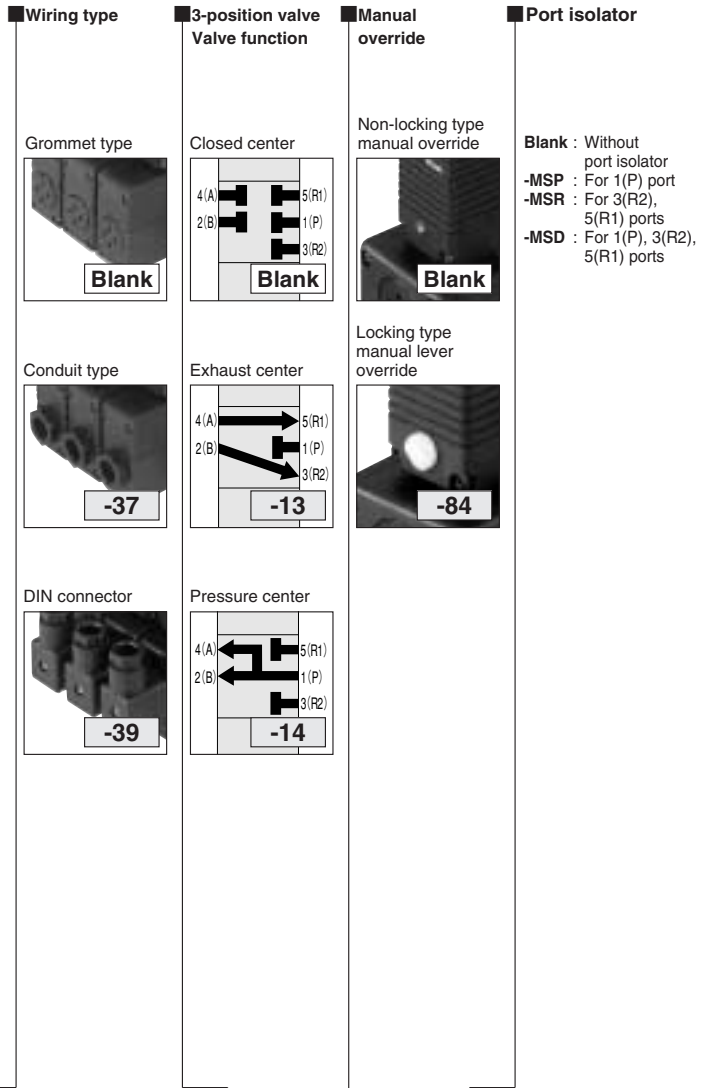

	Manifold model Number of units	Station	Basic model	Manual override	Port isolator	Voltage
Internal pilot manifold	430M 2 ⋮ 10	AT stn. <input type="checkbox"/> ⋮ stn. <input type="checkbox"/>	-430-4E1 -430-4E2 -433-4E2 -432-4E1 -432-4E2	-84 -13,-14 -84	-MSP -MSR -MSD	DC24V AC100V AC200V
External pilot manifold (made to order)	432M	BT		-84		

For made to order details,
see p.759.

- **AT** : Side piping
- **BT** : Bottom piping (made to order)

- Valve mounting location from the left, with wiring cover on top and the 4(A), 2(B) ports in front (: 1~10)

- Specify the valve model for each station.
- Enter **-BP** when closing a station with a block-off plate without mounting a valve.
- To increase the units in the manifold, order the manifold additional units. (For order codes, see p.766.)

- When one of these port isolator order codes is entered to the designated station, the port isolator is installed in the space between the designated station and the station to its right (the side with the larger station number). For details, see the port isolators item on p.765.
Note: The port isolator can be installed to only 1 station on each manifold set.

Operating Principles, Major Parts and Materials

5-port, 2-position

Single solenoid

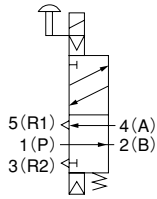

Double solenoid

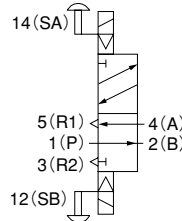

430-4E1

(De-energized)

430-4E2

(De-energized condition after energizing solenoid 12(SB))

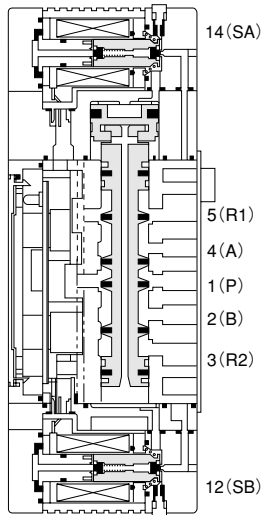
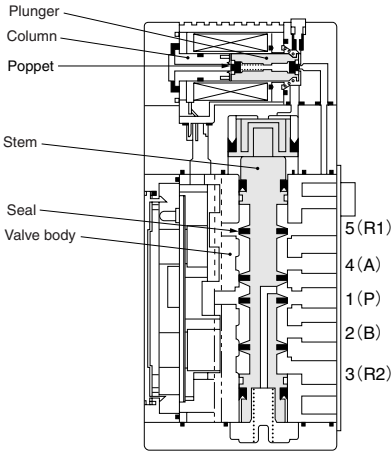

Major Parts and Materials

	Parts	Materials
Valve	Body	Aluminum alloy (painted)
	Stem	Aluminum alloy (anodized)
	Poppet	Synthetic rubber
	Seal	Synthetic rubber
	Plunger	Magnetic stainless steel
	Column	steel
	Sub-base	Aluminum alloy (painted)
Manifold	Body	Aluminum alloy (painted)
	Block-off plate	Mild steel (nickel plated)
	Seal	Synthetic rubber

5-port, 3-position

Closed center

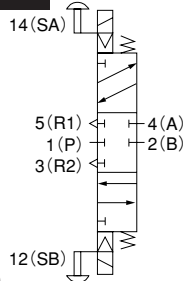

433-4E2

(Both solenoids 14(SA) and 12(SB) are de-energized.)

Exhaust center

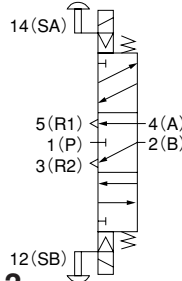

433-4E2-13

(Both solenoids 14(SA) and 12(SB) are de-energized.)

Pressure center

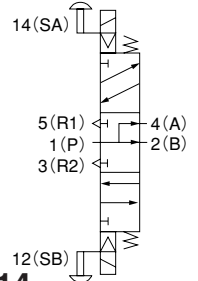

433-4E2-14

(Both solenoids 14(SA) and 12(SB) are de-energized.)

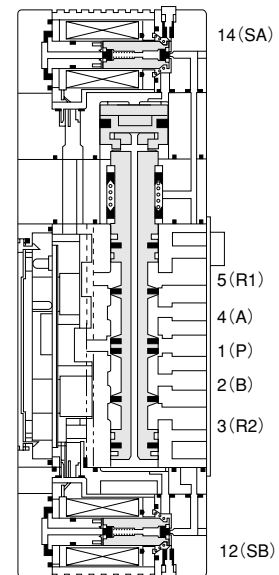
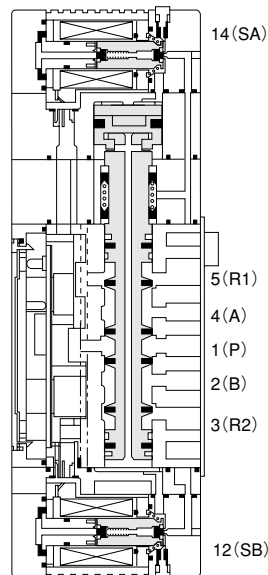
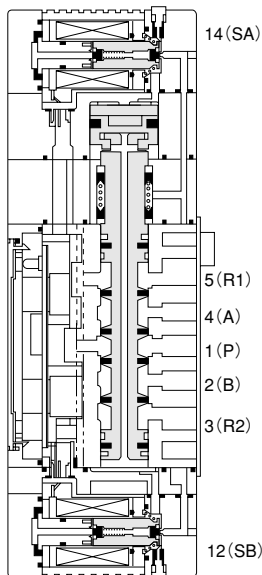

Dimensions of Solenoid Valve (mm)

430-4E1-262 (Grommet type)
430-4E1-263 (Grommet type)

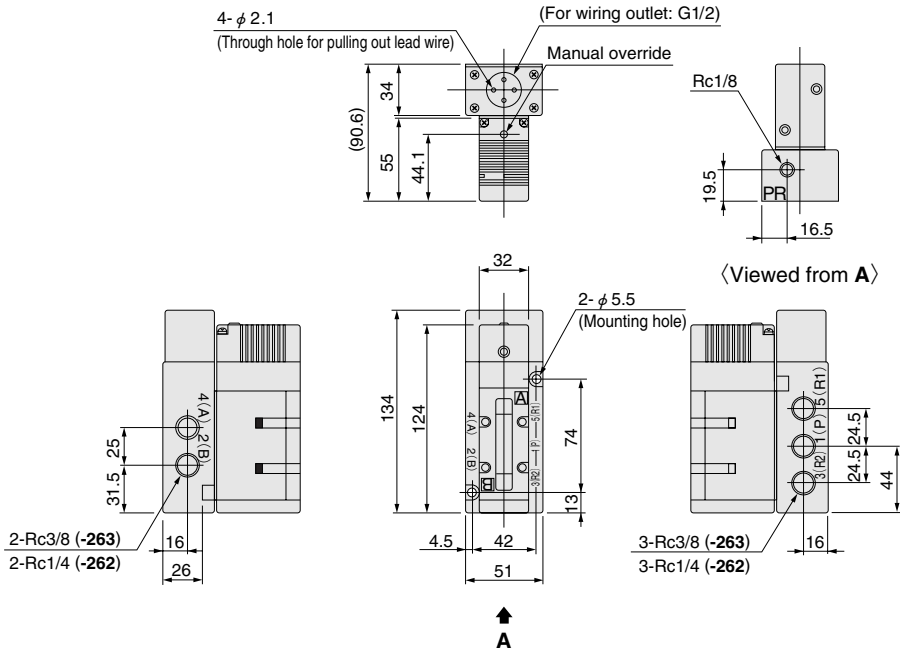

-37 (Conduit type)

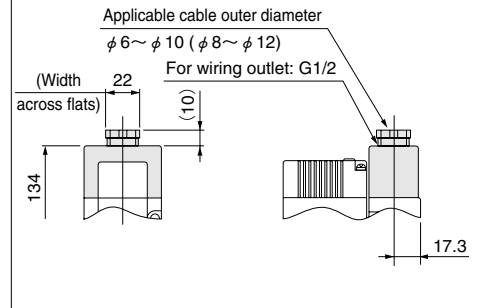
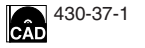

-39 (DIN connector)

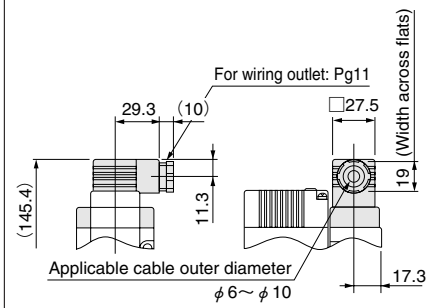

430-4E2-262 (Grommet type)
430-4E2-263 (Grommet type)

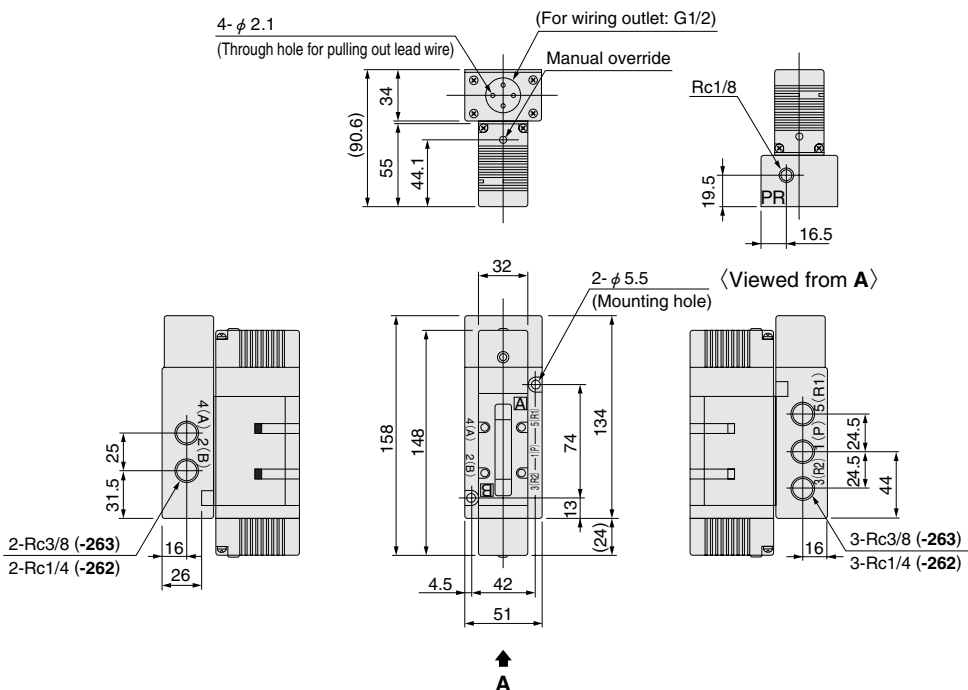

-37 (Conduit type)

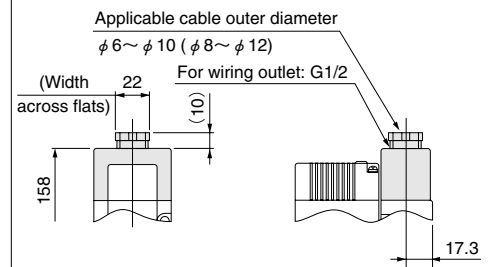
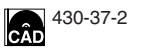

-39 (DIN connector)

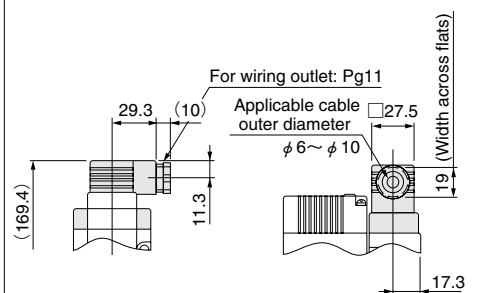
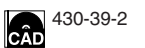

433-4E2-262 (Grommet type)
433-4E2-263 (Grommet type)



-37 (Conduit type)

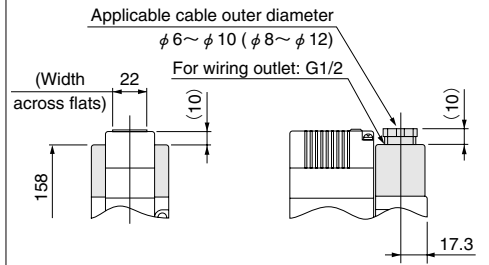
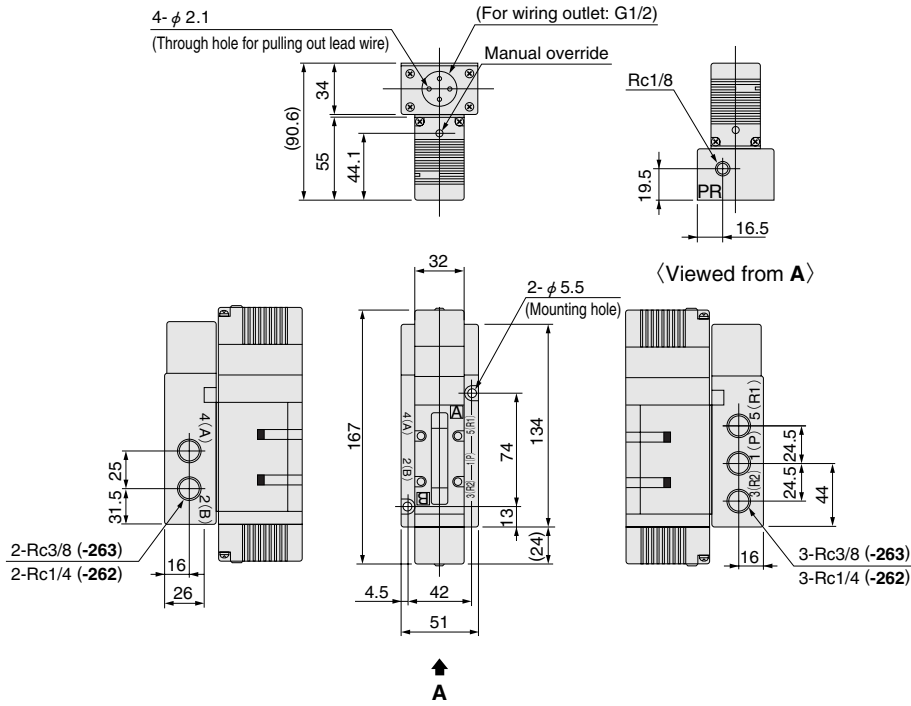
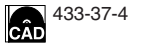

-39 (DIN connector)

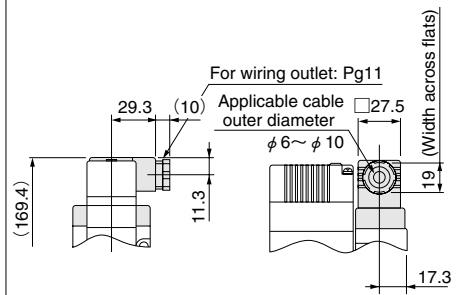
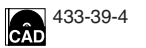

Dimensions of Additional Parts (To be ordered separately) (mm)



● Speed controller: **SCE-02**

● Muffler: **KM-22**

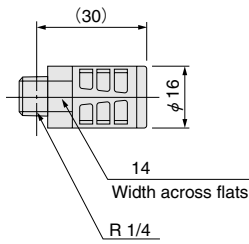
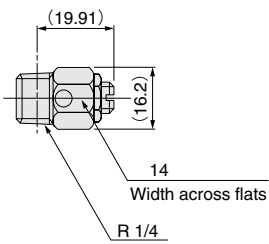

● Speed controller: **SCE-03**

● Muffler: **KM-31**

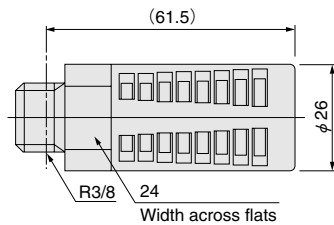
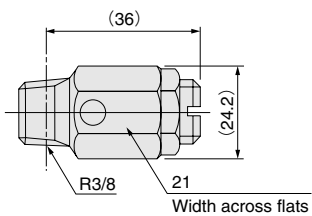

Dimensions of Collective Wiring Manifold (mm)

430M□A (Terminal block)

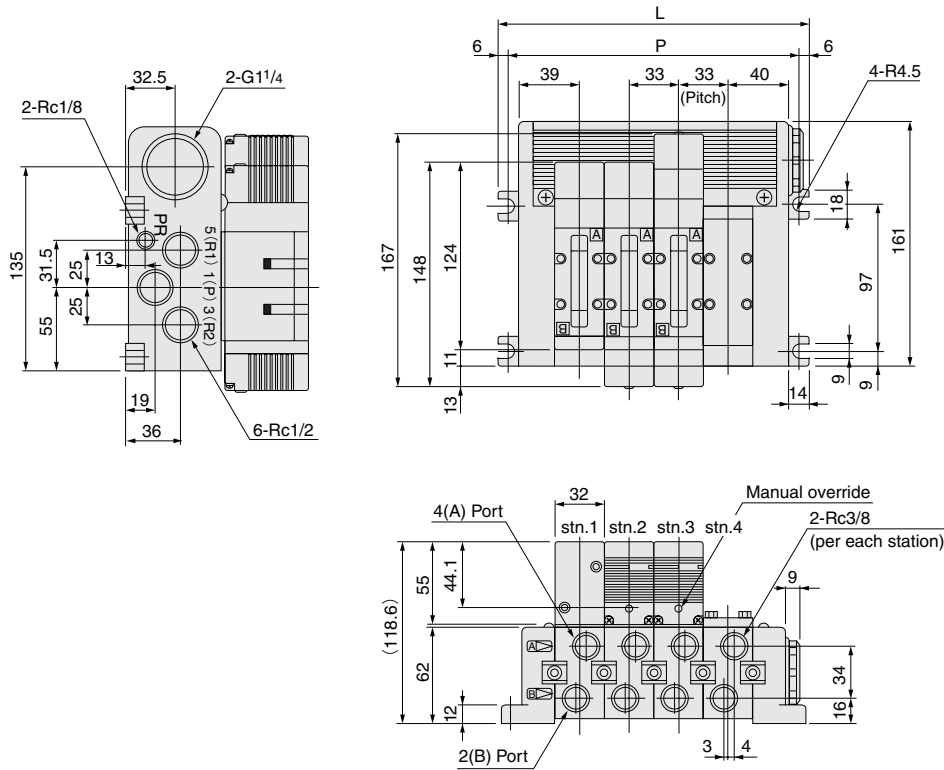

Unit dimensions

Model	L	P
430M2A	140	128
430M3A	173	161
430M4A	206	194
430M5A	239	227
430M6A	272	260
430M7A	305	293
430M8A	338	326
430M9A	371	359
430M10A	404	392

430M□AMR (With multi connector on right side)

430M□AML (With multi connector on left side)

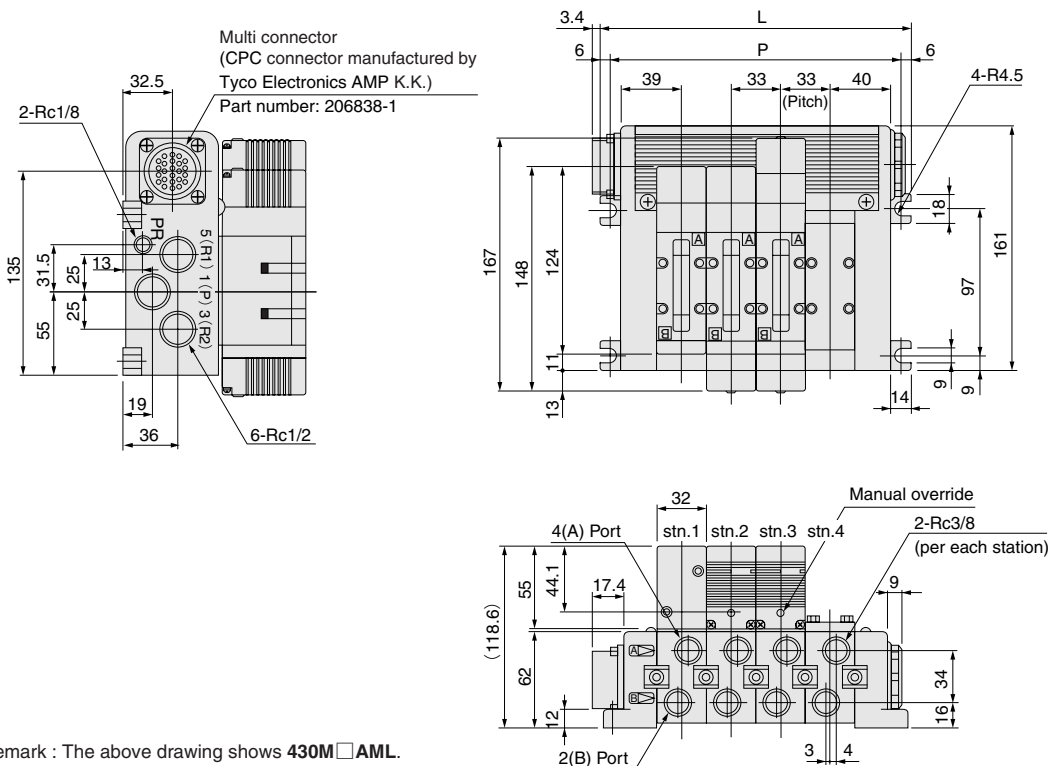

Unit dimensions

Model	L	P
430M2AMR (ML)	140	128
430M3AMR (ML)	173	161
430M4AMR (ML)	206	194
430M5AMR (ML)	239	227
430M6AMR (ML)	272	260
430M7AMR (ML)	305	293
430M8AMR (ML)	338	326

Remark : The above drawing shows 430M□AML.

430M□ADR (With D-sub connector on right side)
430M□ADL (With D-sub connector on left side)

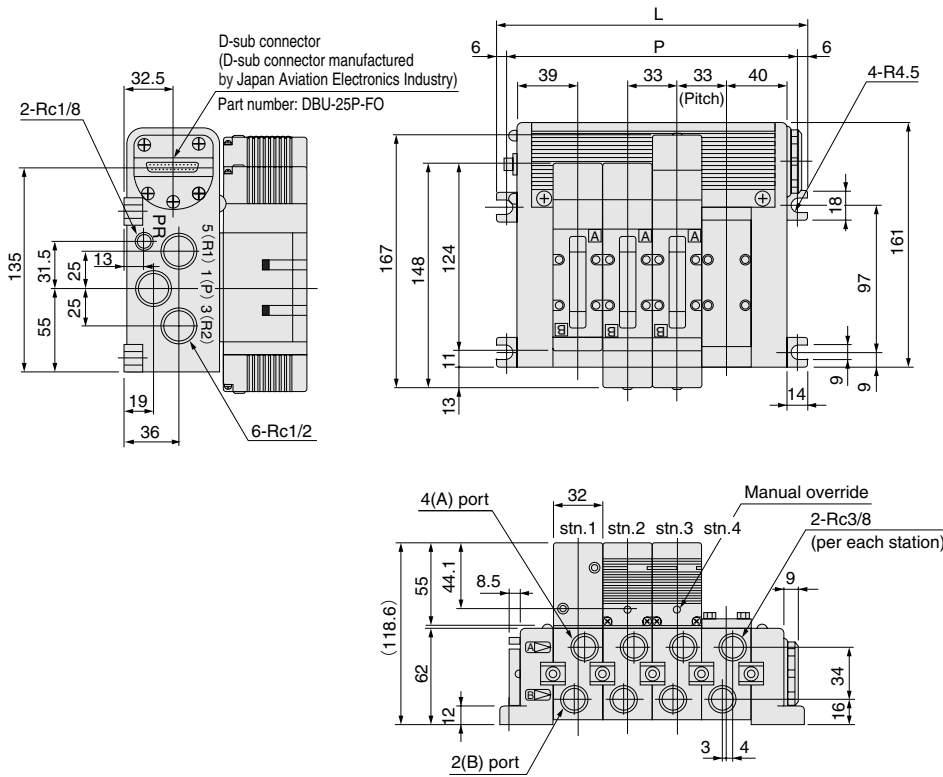

Remark : The above drawing shows 430M□ADL.

Unit dimensions
mm

Model	L	P
430M2ADR (DL)	140	128
430M3ADR (DL)	173	161
430M4ADR (DL)	206	194
430M5ADR (DL)	239	227
430M6ADR (DL)	272	260
430M7ADR (DL)	305	293
430M8ADR (DL)	338	326

430M□ASR (With serial transmission module on right side)
430M□ASL (With serial transmission module on left side)

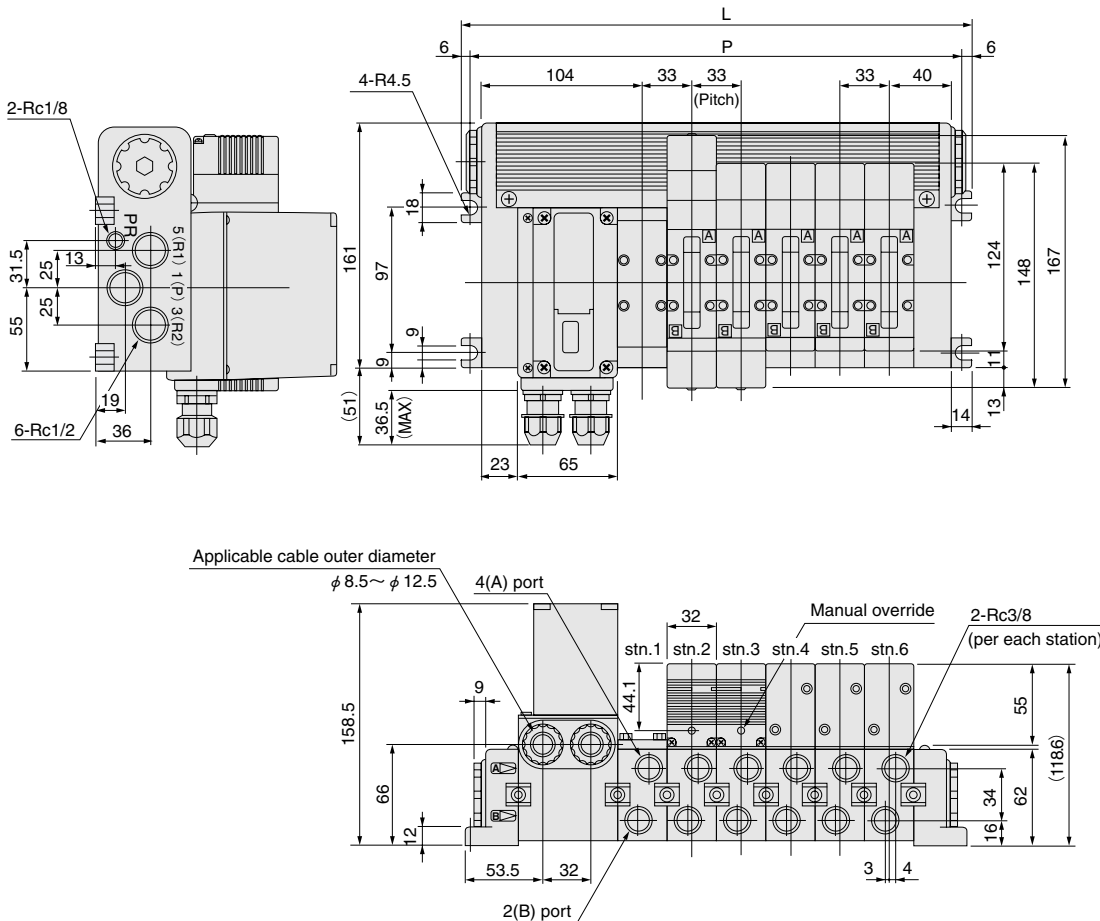

Remark : The above drawing shows 430M□ASL.

Unit dimensions
mm

Model	L	P
430M2ASR (SL)	205	193
430M3ASR (SL)	238	226
430M4ASR (SL)	271	259
430M5ASR (SL)	304	292
430M6ASR (SL)	337	325
430M7ASR (SL)	370	358
430M8ASR (SL)	403	391

Dimensions of Individual Wiring Manifold (mm)

430M□AT (Grommet type)

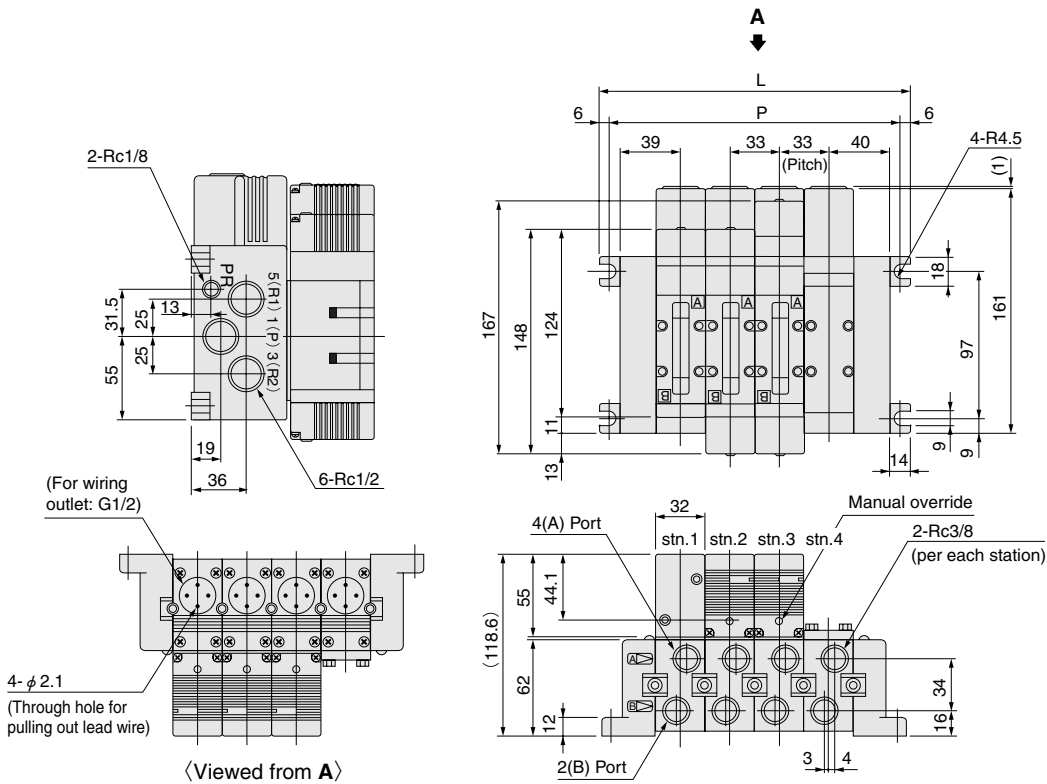

Unit dimensions

Model	L	P
430M2AT	140	128
430M3AT	173	161
430M4AT	206	194
430M5AT	239	227
430M6AT	272	260
430M7AT	305	293
430M8AT	338	326
430M9AT	371	359
430M10AT	404	392

430M□AT-37 (Conduit type)

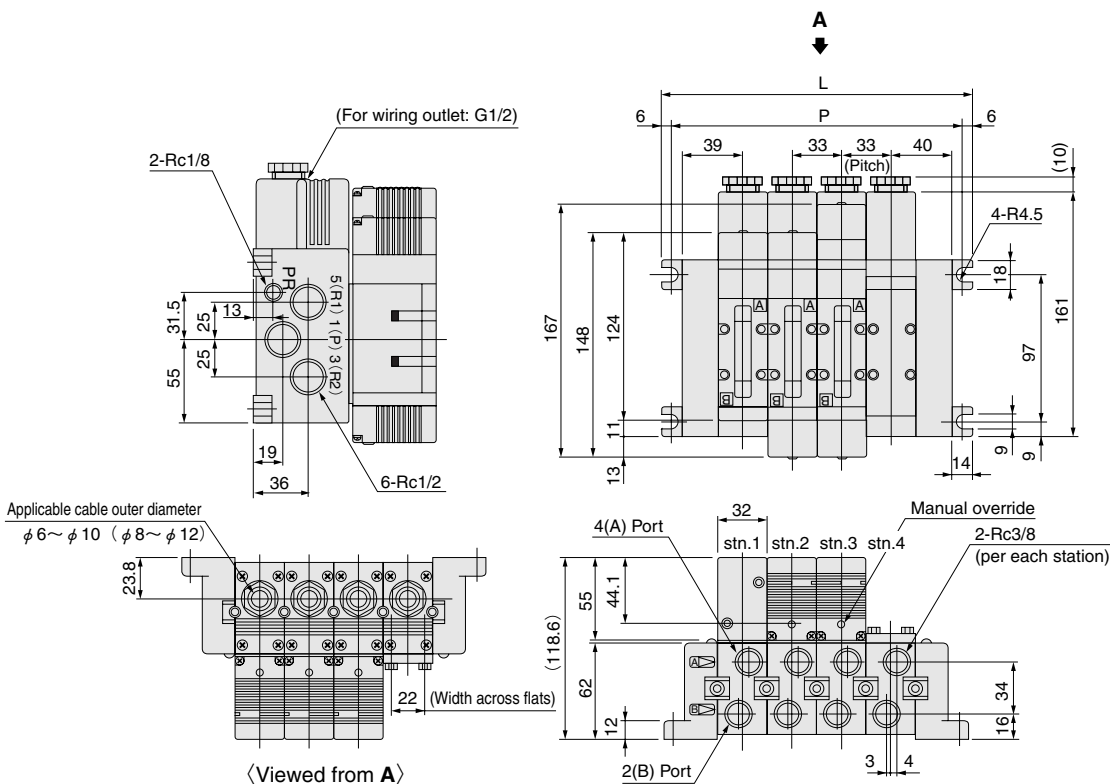

Unit dimensions

Model	L	P
430M2AT-37	140	128
430M3AT-37	173	161
430M4AT-37	206	194
430M5AT-37	239	227
430M6AT-37	272	260
430M7AT-37	305	293
430M8AT-37	338	326
430M9AT-37	371	359
430M10AT-37	404	392

430M □ AT-39 (DIN connector)

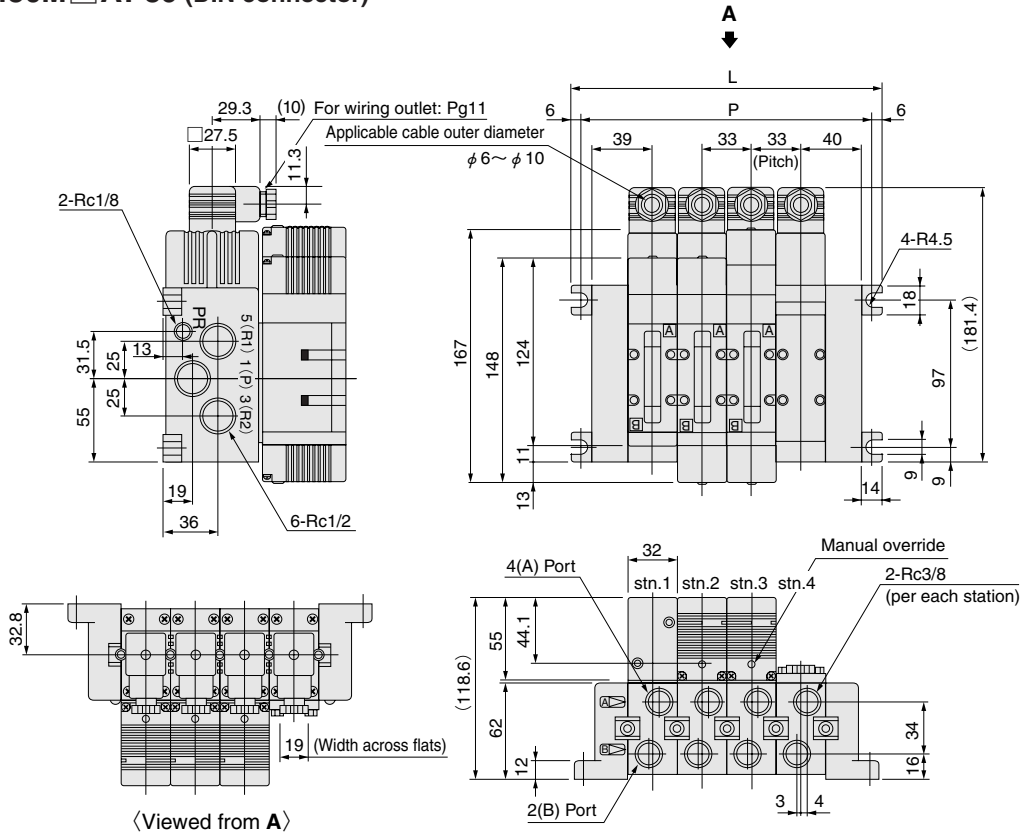

Unit dimensions mm

Model	L	P
430M2AT-39	140	128
430M3AT-39	173	161
430M4AT-39	206	194
430M5AT-39	239	227
430M6AT-39	272	260
430M7AT-39	305	293
430M8AT-39	338	326
430M9AT-39	371	359
430M10AT-39	404	392

SOLENOID VALVES

630 SERIES

Basic Models and Valve Functions

Basic model	630-4E1	630-4E2	633-4E2
Item			
Number of positions	2 positions		3 positions
Number of ports	5 ports		
Valve function	—	—	Closed center (standard) Exhaust center (optional) Pressure center (optional)

Remark: For optional specifications and order codes, see p.743~745.

Specifications

Basic model	630-4E1	630-4E2	633-4E2	
Media	Air			
Operation type	Pilot type			
Effective area ^{Note 1} [Cv]	Port size ^{Note 2}	Rc1/2	60 [3.3]	50 [2.8]
		Rc3/8	55 [3.1]	45 [2.5]
Lubrication	Not required			
Operating pressure range	MPa {kgf/cm ² } [psi.]	0.2~0.9 [2.0~9.2] [29~131]	0.1~0.9 [1.0~9.2] [15~131]	0.2~0.9 [2.0~9.2] [29~131]
Proof pressure	MPa {kgf/cm ² } [psi.]	1.35 {13.8} [196]		
Response time ^{Note 3} ms	DC24V	25/45 or below	20/20 or below	25/40 or below
	AC100V, AC200V	20/45 or below	15/15 or below	20/40 or below
Maximum operating frequency	Hz	5		
Minimum time to energize for self holding	ms	—	50	—
Operating temperature range (atmosphere and media)	°C [°F]	5~50 [41~122]		
Shock resistance	m/s ² [G]	294 [30]		
Mounting direction		Any		

Notes: 1. For details, see the effective area on p.742.

2. For details, see the port size on p.742.

3. Values when the air pressure is 0.5MPa {5.1kgf/cm²} [73psi.]. The values for 630-4E2 are when switching from the opposite position, and for 633-4E2 are those of closed center, when switching from the neutral position.

Solenoid Specifications

Rated voltage	DC24V	AC100V	AC200V	
Item				
Operating voltage range	V	21.6~26.4 (24±10%)	90~110 (100±10%)	180~220 (200±10%)
Rated frequency	Hz	—	50	60
Current (when rated voltage is applied)	Starting	—	68	58
	Energizing	72	42	32
Power consumption	W	1.7	—	—
Allowable leakage current	mA	4	6	3
Insulation resistance ^{Note}	MΩ	Over 100		
Color of LED indicator		Red	Yellow	Green
Surge suppression (as standard)		Surge absorption transistor	Varistor	

Note: Value at DC500V megger.

Cylinder Operating Speed

630-4E1-263

Maximum operating speed

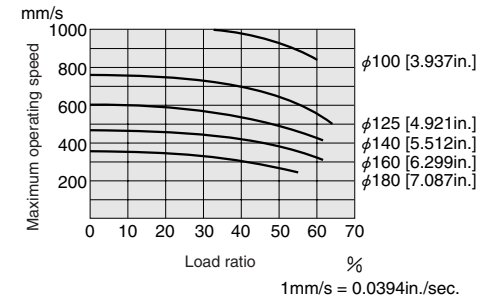

Delay time

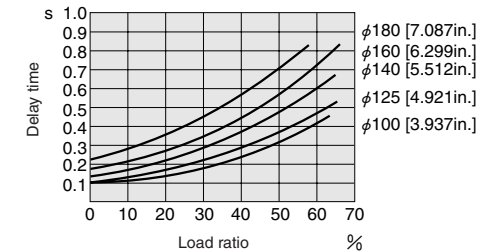

Measurement conditions

- Air pressure: 0.5MPa {5.1kgf/cm²} [73psi.]
- Piping inner diameter and length: φ7.5×1000mm [39in.]
- Fitting: Quick fitting (Model: TS10-04)
- Load ratio = $\frac{\text{Load}}{\text{Cylinder theoretical thrust}}$ (%)
- Cylinder stroke: 300mm [11.8in.]

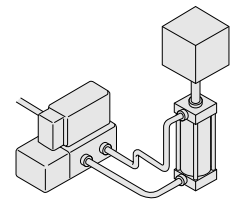

How to obtain cylinder speed

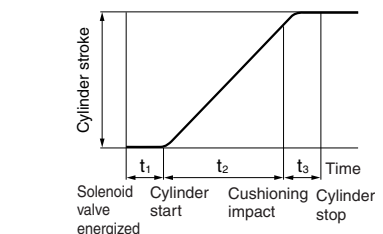

t = Time required for the cylinder to complete 1 stroke

t₁ = Cylinder delay time

t₂ = Time moving at maximum speed

t₃ = Time required for cushioning (about 0.2s)

● Without cushion

t = t₁+t₂

● With cushion

t = t₁+t₂+t₃

633-4E2-263

Maximum operating speed

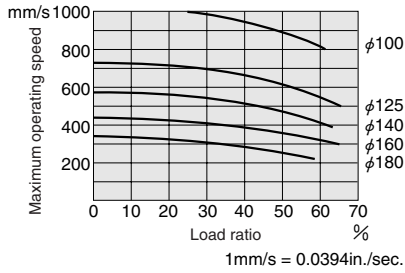

Delay time

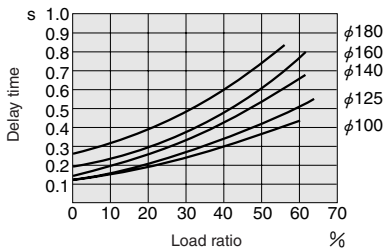

Measurement conditions

- Air pressure: 0.5MPa {5.1kgf/cm²} [73psi.]
- Piping inner diameter and length: φ 7.5×1000mm [39in.]
- Fitting: Quick fitting (Model: TS10-04)
- Load ratio = $\frac{\text{Load}}{\text{Cylinder theoretical thrust}}$ (%)
- Cylinder stroke: 300mm [11.8in.]

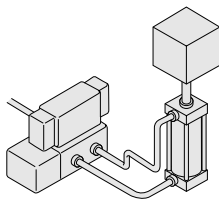

Effective Area [Cv]

Model	Port size	Standard mm ² Note 1	Effective area mm ² Note 2	Fitting size
630-4E1 630-4E2	Rc1/2	60 (3.33)	53 [2.9]	TS 12-04
			38 [2.1]	TS 10-04
	Rc3/8	55 (3.05)	52 [2.9]	TS 12-03
			36 [2.0]	TS 10-03
633-4E2	Rc1/2	50 (2.77)	42 [2.3]	TS 12-04
			27 [1.5]	TS 10-04
	Rc3/8	45 (2.5)	38 [2.1]	TS 12-03
			27 [1.5]	TS 10-03
			17 [0.9]	TS 8-03

Notes: 1. Values for a single valve unit.
2. Values when fittings are attached on 1(P), 4(A), and 2(B) ports. Fitting size is as shown in the table above.

Solenoid Valve Port Size

Model	Port specification	Sub-base port size
630-4E□-264 633-4E2-264	1 (P)	Female thread Rc 1/2
	4 (A), 2 (B)	
	3 (R2), 5 (R1)	
	PR	
630-4E□-263 633-4E2-263	1 (P)	Female thread Rc 3/8
	4 (A), 2 (B)	
	3 (R2), 5 (R1)	
	PR	
		Rc 1/8
		Rc 1/8

Manifold Connection Port Size

Manifold model	Port	Piping size
630M□A	1 (P)	Rc1/2
	4 (A), 2 (B)	
	3 (R2), 5 (R1)	
	PR	
		Rc1/8

Solenoid Valve Mass g [oz.]

Basic model	Mass
630-4E1	490 [17.28] (1070 [37.74])
630-4E2	610 [21.52] (1190 [41.98])
633-4E2	590 [20.81] (1170 [41.27])

Remark: Figures in parentheses () are the mass with sub-base.

Manifold Mass g [oz.]

Manifold model	Mass calculation of each unit (n=Number of units)	Block-off plate (Model: 630M-BP)
630M□A	(590×n)+1040 [(20.81×n)+36.68]	130 [4.59]
630M□AT	(650×n)+830 [(22.93×n)+29.28]	

Flow Rate

630-4E1-263
630-4E2-263

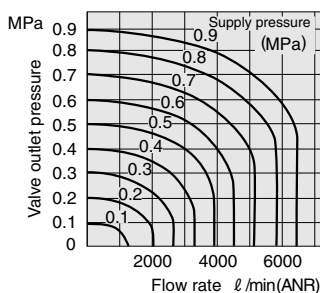

633-4E2-263

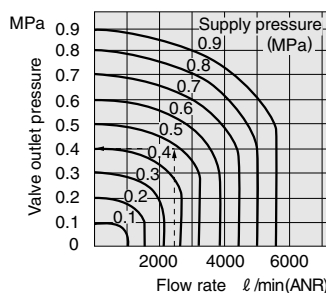

1MPa = 145psi., 1 l / min = 0.0353ft.³/min.

How to read the graph

When the supply pressure is 0.5MPa [73psi.] and the flow rate is 2420 l / min [85.4ft.³/min.] (ANR), the valve outlet pressure becomes 0.4MPa [58psi.].

630 Series Solenoid Valve Order Codes



		3-position valve Valve function	Sub-base	Manual override	Wiring type
		Closed center Blank	Port size Rc3/8, side piping -263	Non-locking type Manual override Blank	Grommet type Blank
		Exhaust center -13	Port size Rc1/2, side piping -264	Locking type Manual lever override -84	Conduit type -37
		Pressure center -14	Port size Rc3/8, bottom piping (made to order) -283		DIN connector -39
			Port size Rc1/2, bottom piping (made to order) -284		
			● When ordering single valve units, omit this code from the order code. The single valve includes 4 mounting screws and 1 gasket.		
		Basic model			Voltage
Internal pilot sub-base	5-port, 2-position single solenoid	630-4E1	-263	-84	DC24V AC100V AC200V
	5-port, 2-position double solenoid	630-4E2	-264		
	5-port, 3-position double solenoid	633-4E2	-13, -14	-84	
External pilot sub-base (made to order)	5-port, 2-position single solenoid	632-4E1	-283	-84	
	5-port, 2-position double solenoid	632-4E2	-284		

For made to order details, see p.759.

Additional Parts (To be ordered separately)

Speed controller



●For Rc3/8

●For Rc1/2

Muffler



●For Rc3/8





●For Rc1/2

Block-off plate

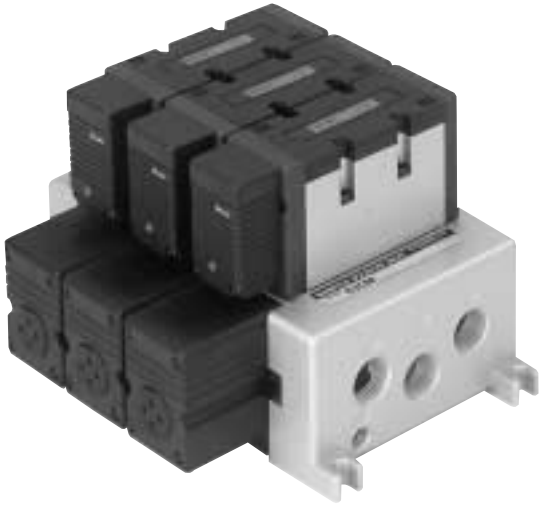

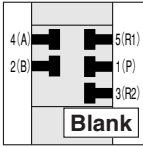
630 Series Individual Wiring Manifold Order Codes

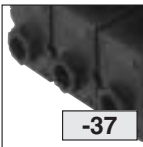
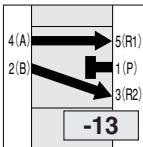

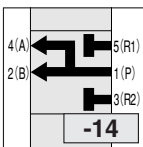
Wiring type	3-position valve Valve function	Manual override	Port isolator
Grommet type  Blank	Closed center  Blank	Non-locking type manual override  Blank	Blank : Without port isolator -MSP : For 1(P) port -MSR : For 3(R2), 5(R1) ports -MSD : For 1(P), 3(R2), 5(R1) ports
Conduit type  -37	Exhaust center  -13	Locking type manual lever override  -84	
DIN connector  -39	Pressure center  -14		

	Manifold model Number of units	Station	Basic model	Manual override	Port isolator	Voltage
Internal pilot manifold	630M 2 ⋮ 10	AT	-37 -39	stn. <input type="checkbox"/> ⋮ stn. <input type="checkbox"/>	-630-4E1 -630-4E2 -633-4E2 -632-4E1 -632-4E2	-84 -MSP -MSR -MSD DC24V AC100V AC200V
External pilot manifold (made to order)	632M	BT			-13,-14 -84	

For made to order details,
see p.759.

- **AT** : Side piping
- **BT** : Bottom piping (made to order)
- Valve mounting location from the left, with wiring cover on top and the 4(A), 2(B) ports in front (□ : 1~10)
- Specify the valve model for each station.
- Enter **-BP** when closing a station with a block-off plate without mounting a valve.
- To increase the units in the manifold, order additional manifold units. (For order codes, see p.766.)

- When one of these port isolator order codes is entered to the designated station, the port isolator is installed in the space between the designated station and the station to its right (the side with the larger station number). For details, see the port isolators item on p.765.
Note: The port isolator can be installed to only 1 station on each manifold set.

Operating Principles, Major Parts and Materials

5-port, 2-position

Single solenoid

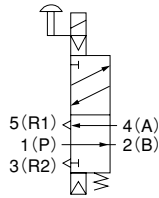

Double solenoid

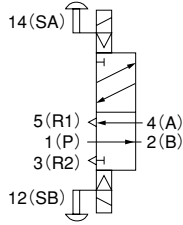

630-4E1

(De-energized)

630-4E2

(De-energized condition after energizing solenoid 12(SB))

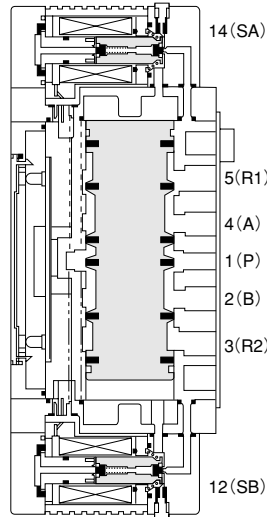
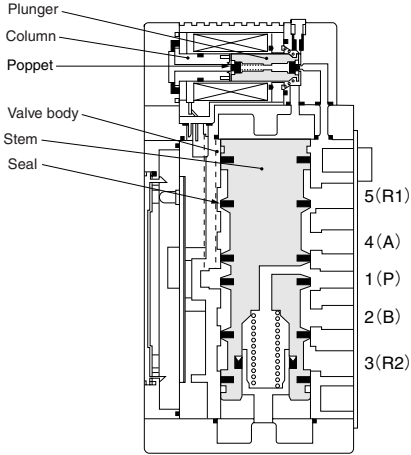

Major Parts and Materials

Parts	Materials	
Valve	Body	Aluminum alloy (painted)
	Stem	Aluminum alloy (anodized)
	Poppet	Synthetic rubber
	Seal	Synthetic rubber
	Plunger	Magnetic stainless steel
	Column	Aluminum alloy (painted)
Manifold	Body	Aluminum alloy (painted)
	Block-off plate	Mild steel (nickel plated)
	Seal	Synthetic rubber

5-port, 3-position

Closed center

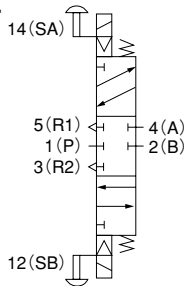

Exhaust center

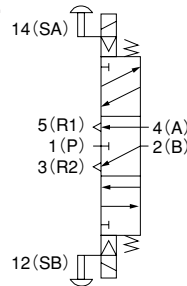

Pressure center

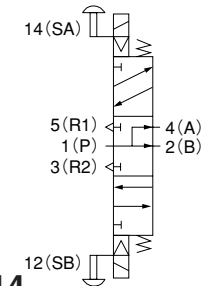

633-4E2

(Both solenoids 14(SA) and 12(SB) are de-energized.)

633-4E2-13

(Both solenoids 14(SA) and 12(SB) are de-energized.)

633-4E2-14

(Both solenoids 14(SA) and 12(SB) are de-energized.)

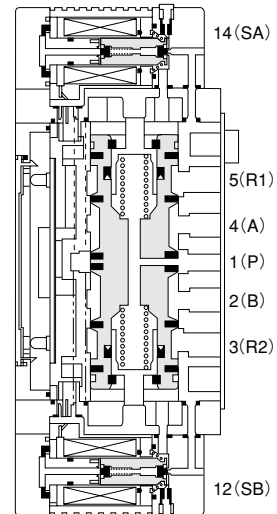
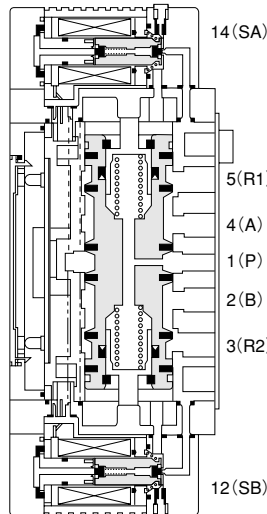
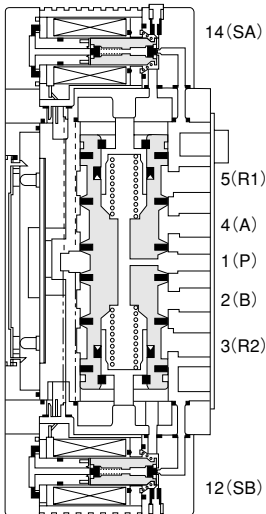

Dimensions of Solenoid Valve (mm)

630-4E1-263 (Grommet type)
630-4E1-264 (Grommet type)

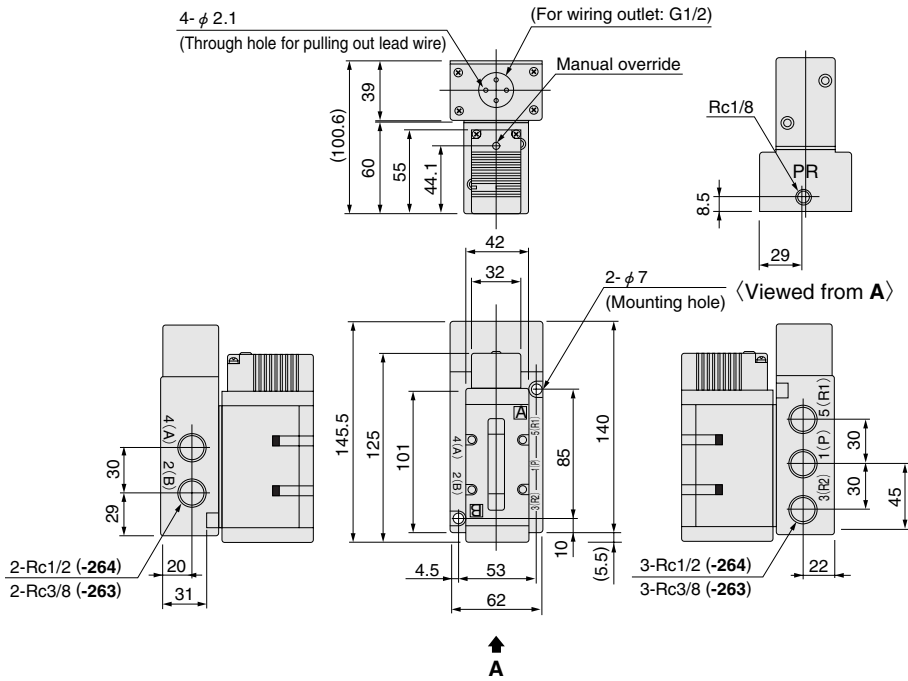

-37 (Conduit type)

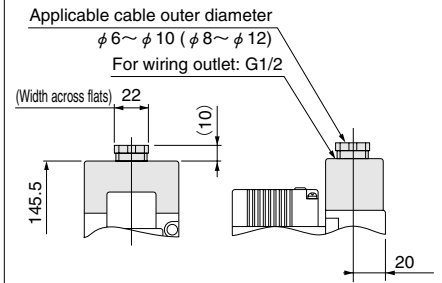
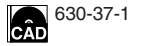

-39 (DIN connector)

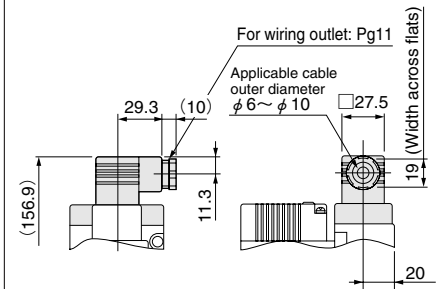

630-4E2-263 (Grommet type)
630-4E2-264 (Grommet type)

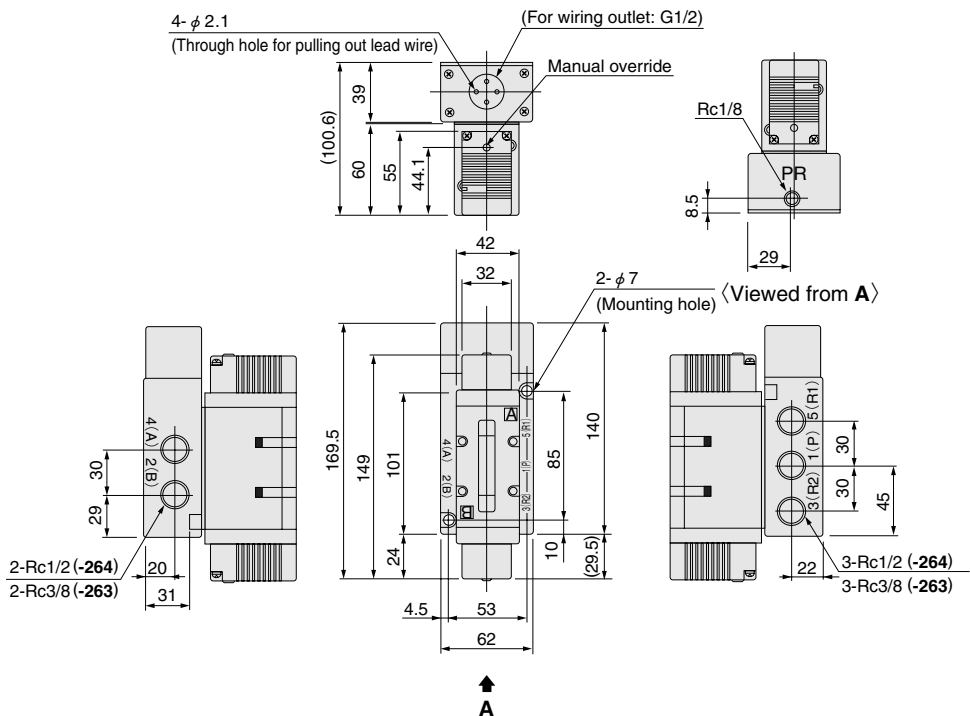

-37 (Conduit type)

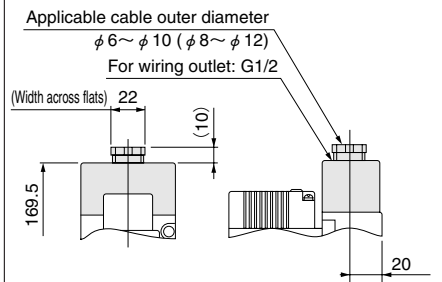
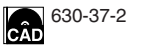

-39 (DIN connector)

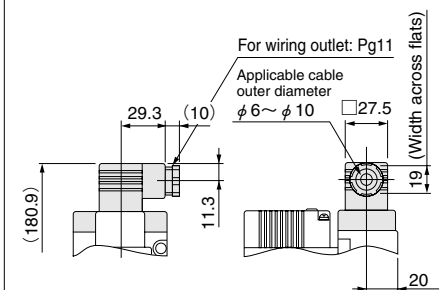
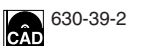

633-4E2-263 (Grommet type)
633-4E2-264 (Grommet type)

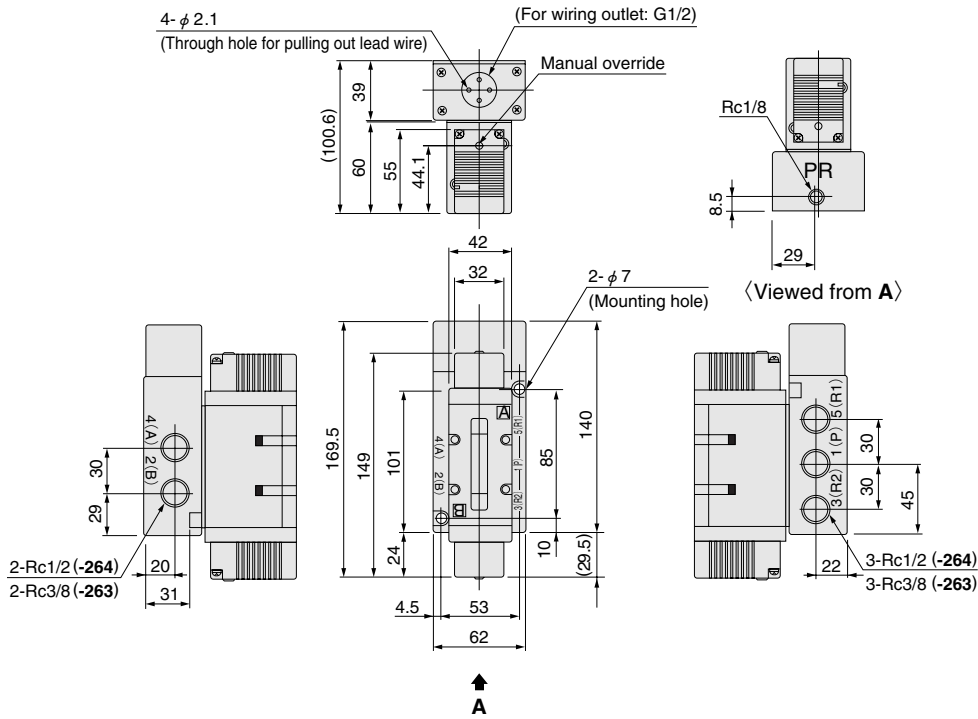

-37 (Conduit type)

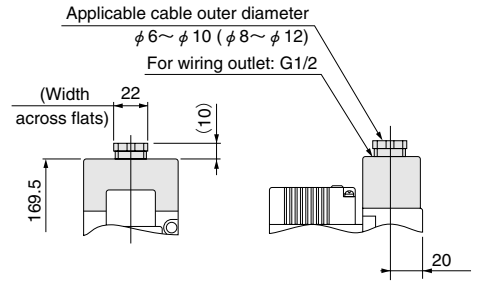
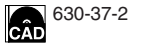

-39 (DIN connector)

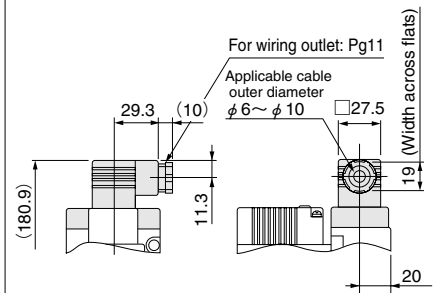

Dimensions of Additional Parts (To be ordered separately) (mm)



● Speed controller: **SCE-03**

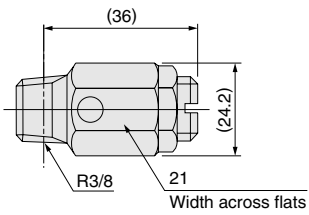

● Speed controller: **SCE-04**

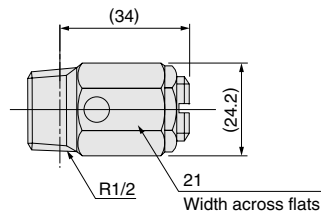

● Muffler: **KM-31**

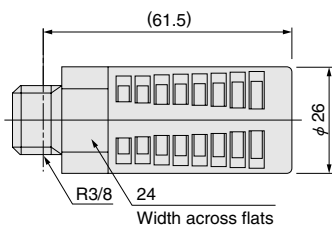

● Muffler: **KM-41**

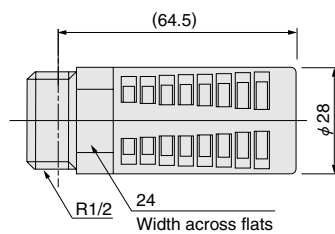

Dimensions of Collective Wiring Manifold (mm)

630M□A (Terminal block)

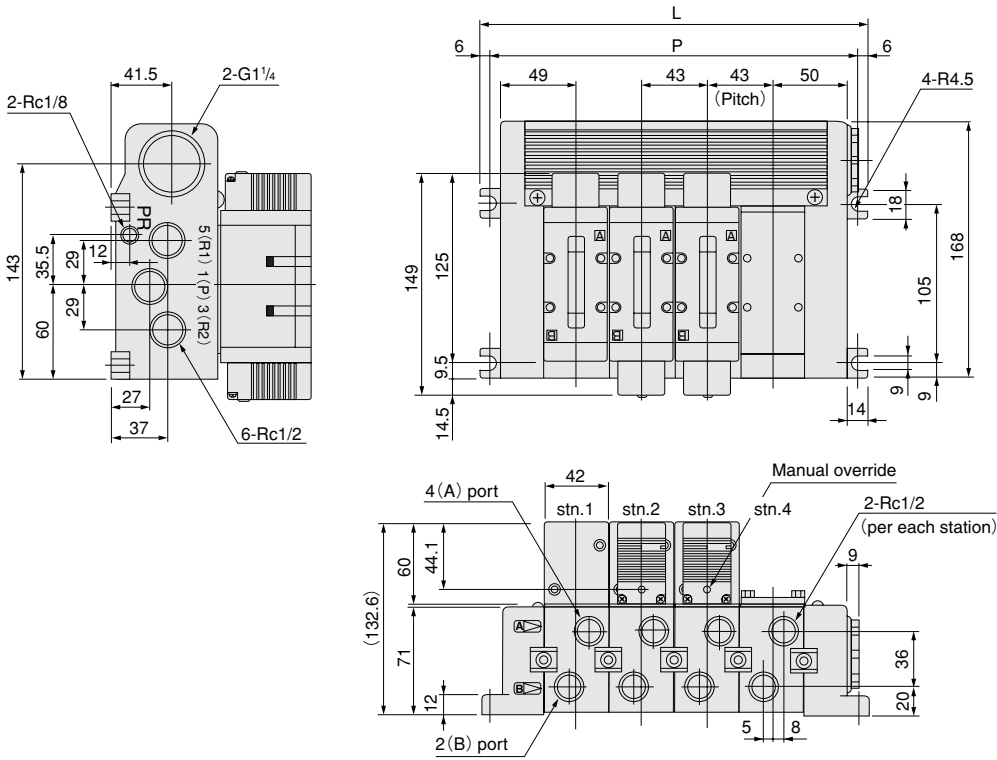

Unit dimensions

Model	mm	
	L	P
630M2A	170	158
630M3A	213	201
630M4A	256	244
630M5A	299	287
630M6A	342	330
630M7A	385	373
630M8A	428	416
630M9A	471	459
630M10A	514	502

630M□AMR (With multi connector on right side) 630M□AML (With multi connector on left side)

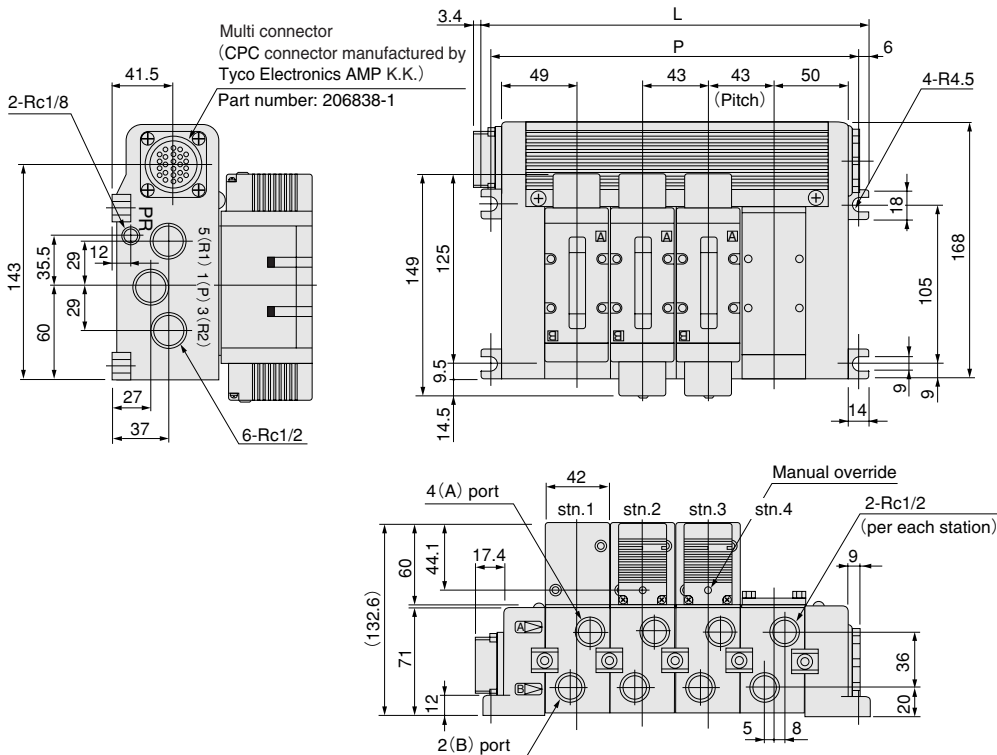

Unit dimensions

Model	mm	
	L	P
630M2AMR(ML)	170	158
630M3AMR(ML)	213	201
630M4AMR(ML)	256	244
630M5AMR(ML)	299	287
630M6AMR(ML)	342	330
630M7AMR(ML)	385	373
630M8AMR(ML)	428	416

Remark: The above drawing shows 630M□AML.

630M□ADR (With D-sub connector on right side)
 630M□ADL (With D-sub connector on left side)

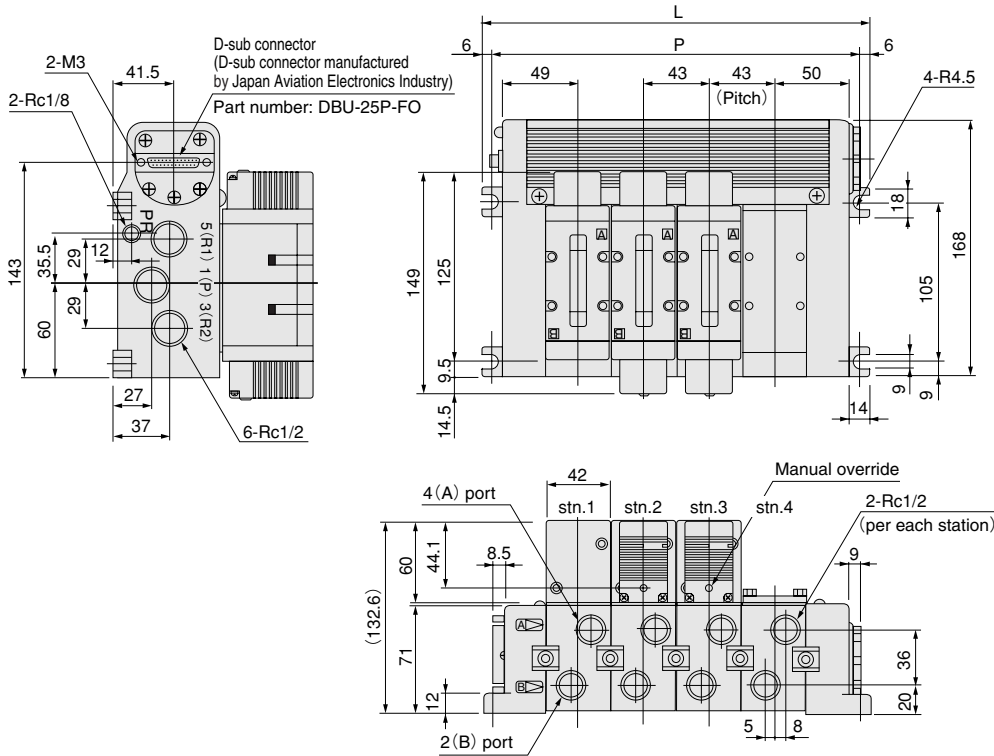

Unit dimensions

Model	mm	
	L	P
630M2ADR(DL)	170	158
630M3ADR(DL)	213	201
630M4ADR(DL)	256	244
630M5ADR(DL)	299	287
630M6ADR(DL)	342	330
630M7ADR(DL)	385	373
630M8ADR(DL)	428	416

Remark: The above drawing shows 630M□ADL.

Dimensions of Individual Wiring Manifold (mm)

630M□AT (Grommet type)

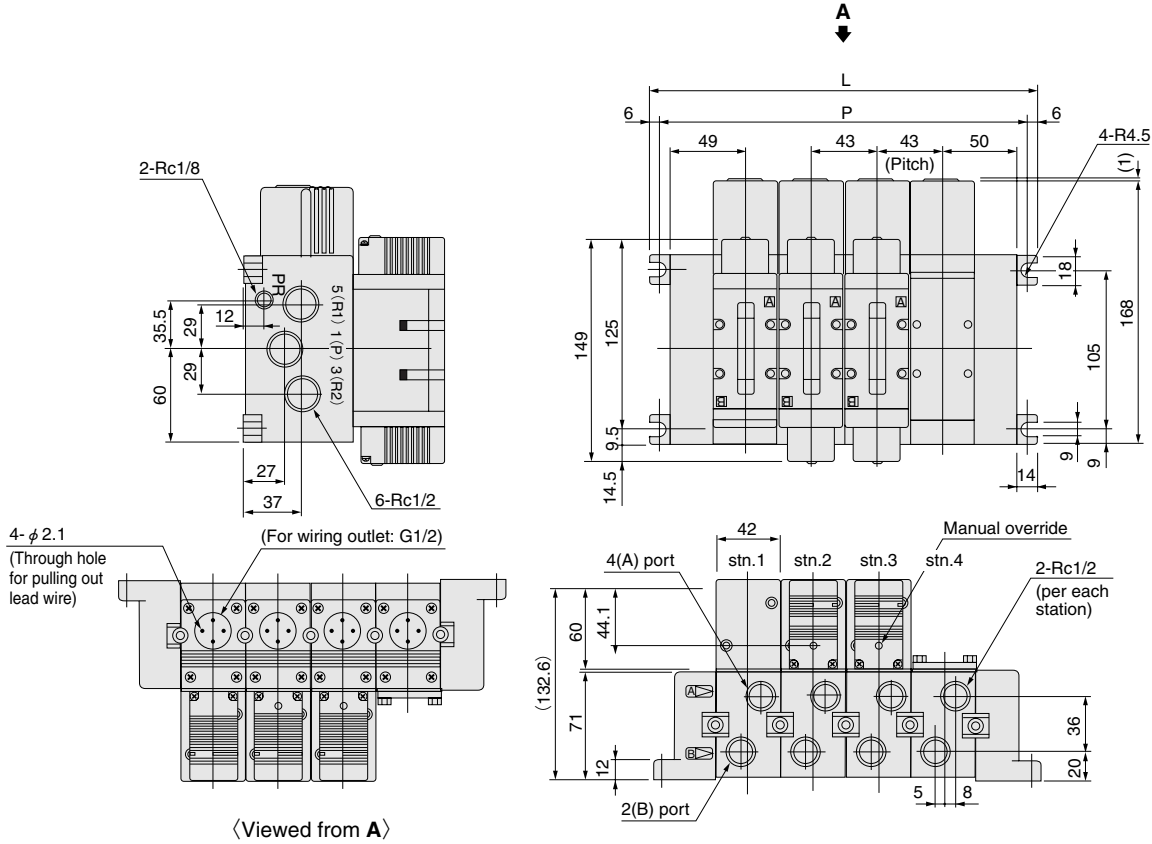

Unit dimensions mm

Model	L	P
630M2AT	170	158
630M3AT	213	201
630M4AT	256	244
630M5AT	299	287
630M6AT	342	330
630M7AT	385	373
630M8AT	428	416
630M9AT	471	459
630M10AT	514	502

630M□AT-37 (Conduit type)

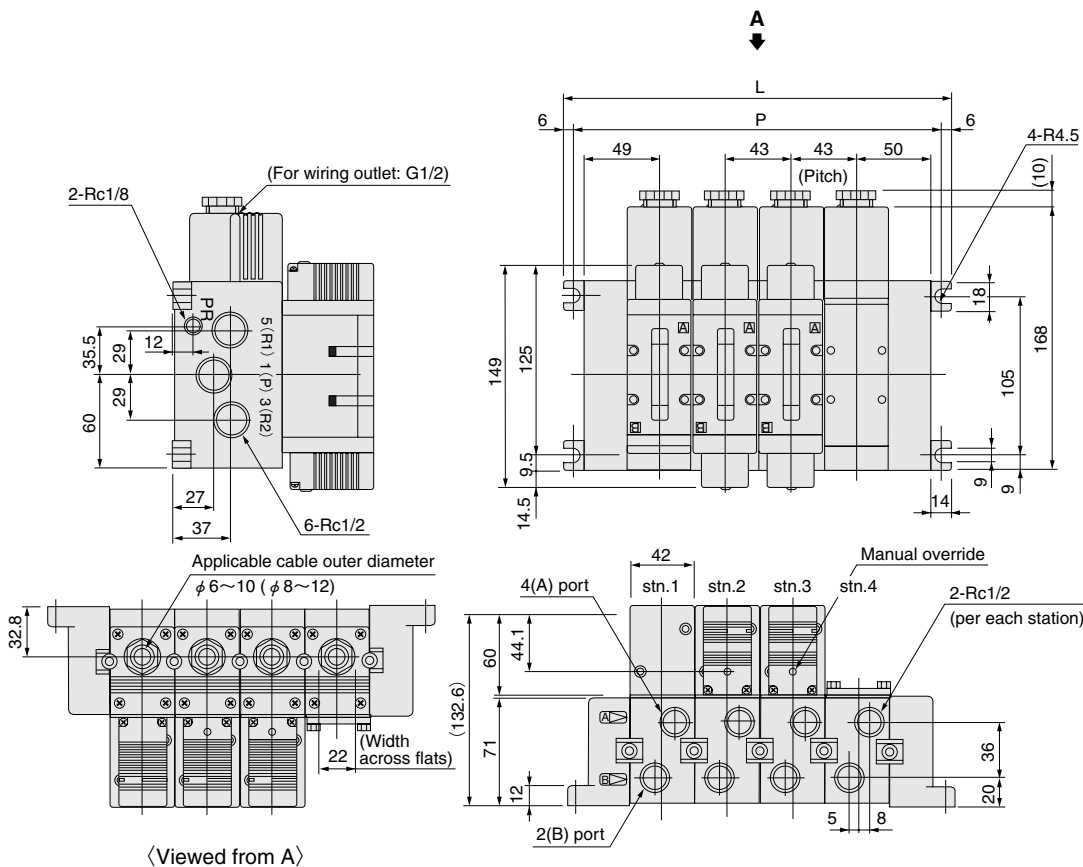

Unit dimensions mm

Model	L	P
630M2AT-37	170	158
630M3AT-37	213	201
630M4AT-37	256	244
630M5AT-37	299	287
630M6AT-37	342	330
630M7AT-37	385	373
630M8AT-37	428	416
630M9AT-37	471	459
630M10AT-37	514	502

630M□ AT-39 (DIN connector)

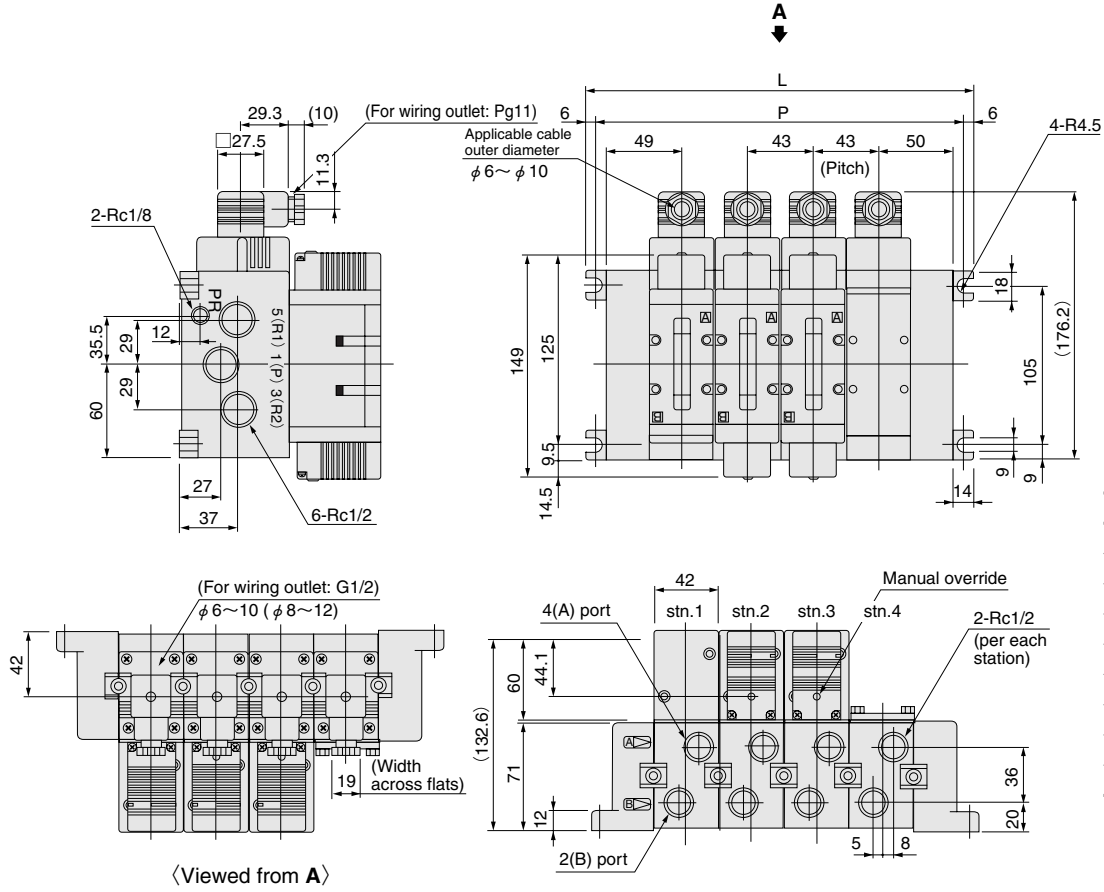

Unit dimensions mm

Model	L	P
630M2AT-39	170	158
630M3AT-39	213	201
630M4AT-39	256	244
630M5AT-39	299	287
630M6AT-39	342	330
630M7AT-39	385	373
630M8AT-39	428	416
630M9AT-39	471	459
630M10AT-39	514	502

SOLENOID VALVES

830 SERIES

Basic Models and Valve Functions

Basic model	830-4E1	830-4E2	833-4E2
Item			
Number of positions	2 positions		3 positions
Number of ports	5 ports		
Valve function	—	—	Closed center (standard) Exhaust center (optional) Pressure center (optional)

Remark: For optional specifications and order codes, see p.755.

Specifications

Basic model	830-4E1	830-4E2	833-4E2
Media	Air		
Operation type	Pilot type		
Effective area ^{Note 1} mm ² [Cv]	Port size ^{Note 2} Rc3/4	120 [6.7]	
	Rc1/2	100 [5.6]	
Lubrication	Not required		
Operating pressure range MPa {kgf/cm ² } [psi.]	0.2~0.9 [2.0~9.2] [29~131]	0.1~0.9 [1.0~9.2] [15~131]	0.2~0.9 [2.0~9.2] [29~131]
Proof pressure MPa {kgf/cm ² } [psi.]	1.35 {13.8} [196]		
Response time ^{Note 3} ms	DC24V	30/60 or below	20/20 or below
ON/OFF	AC100V, AC200V	25/75 or below	20/20 or below
Maximum operating frequency	Hz	5	
Minimum time to energize for self holding	ms	—	50
Operating temperature range (atmosphere and media) °C [°F]	5~50 [41~122]		
Shock resistance	m/s ² [G]	294 {30}	
Mounting direction	Any		

Notes: 1. For details, see the effective area on p.754.

2. For details, see the port size on p. 754.

3. Values when the air pressure is 0.5MPa {5.1kgf/cm²} [73psi.]. The values for **830-4E2** are when switching from the opposite position, and for **833-4E2** are those of closed center, when switching from the neutral position.

Solenoid Specifications

Rated voltage	DC24V	AC100V	AC200V
Item			
Operating voltage range	V	21.6~26.4 (24±10%)	90~110 (100±10%)
Rated frequency	Hz	—	50 60
Current (When rated voltage is applied)	mA (r.m.s)	Starting	68 58
		Energizing	72 42 32
Power consumption	W	1.7	—
Allowable leakage current	mA	4	6
Insulation resistance ^{Note}	MΩ	Over 100	
Color of LED indicator		Red	Yellow
Surge suppression (as standard)		Surge absorption transistor	Varistor

Note: Value at DC500V megger.

Cylinder Operating Speed

● For tube piping

830-4E □ -264
833-4E2-264

Maximum operating speed

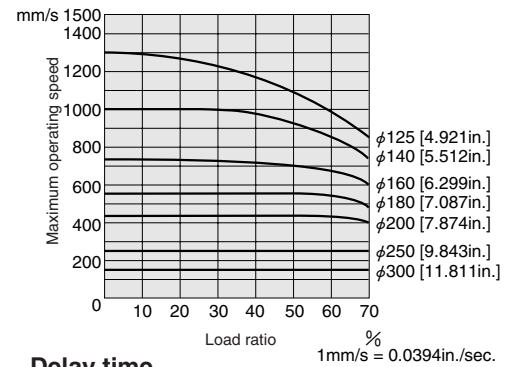

Delay time

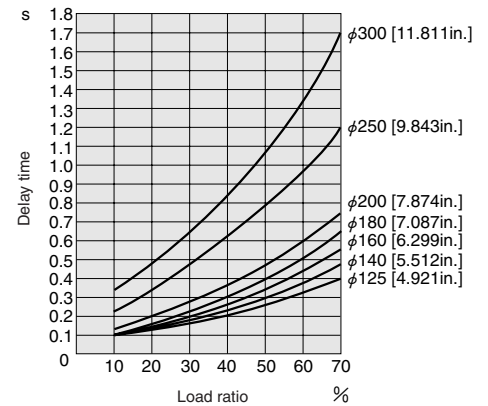

Measurement conditions

- Air pressure: 0.5MPa {5.1kgf/cm²} [73psi.]
- Piping inner diameter and length: φ13×1000mm [39in.]
- Fitting: Quick fitting (Model: TS16-04)
- Load ratio = $\frac{\text{Load}}{\text{Cylinder theoretical thrust}} (\%)$
- Cylinder stroke: 300mm [11.8in.]

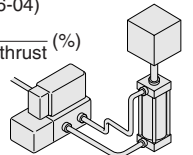

How to obtain cylinder speed

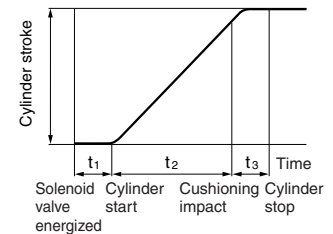

t = Time required for the cylinder to complete 1 stroke

t₁ = Cylinder delay time

t₂ = Time moving at maximum speed

t₃ = Time required for cushioning (about 0.2s)

● Without cushion

t = t₁ + t₂

● With cushion

t = t₁ + t₂ + t₃

● For steel piping

830-4E□-266
833-4E2-266

Maximum operating speed

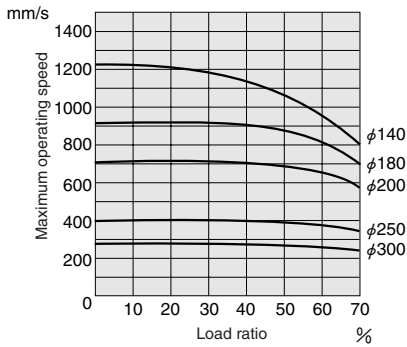

Delay time

1mm/s = 0.0394in./sec.

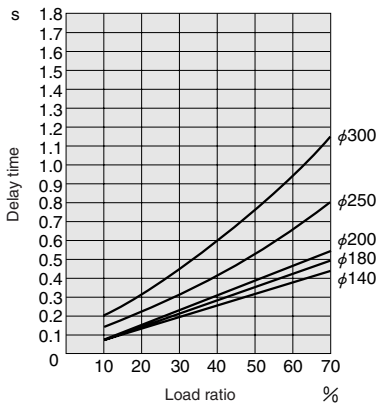

Measurement conditions

- Air pressure: 0.5MPa {5.1kgf/cm²} [73psi.]
- Piping length: 20A steel piping 2m, elbow in 2 places
- Fitting: R3/4 steel piping fitting
- Load ratio = $\frac{\text{Load}}{\text{Cylinder theoretical thrust}}$ (%)
- Cylinder stroke: 300mm [11.8in.]

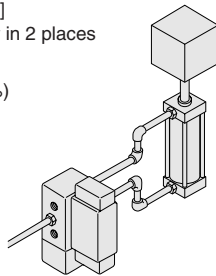

Effective Area [Cv]

Model	Port size	Effective area mm ²				
		Standard (without fitting)	Tube piping		Steel piping	
			Inner diameter φ 13×1m TS16-04 2 pcs.	Inner diameter φ 13×2m TS16-04 2 pcs.	R3/4×2m Elbow 2 pcs.	R1/2×2m Elbow 2 pcs.
830-4E1 830-4E2	Rc3/4	120 [6.7]	72 [4.0]	68 [3.8]	105 [5.8]	77 [4.3]
833-4E2	Rc1/2	100 [5.6]	68 [3.8]	64 [3.6]	—	75 [4.2]

Solenoid Valve Port Size

Model	Port specification	Sub-base port size
830-4E□-266 833-4E2-266	1 (P)	Rc 3/4
	4 (A), 2 (B)	
	3 (R2), 5 (R1)	
	PR	
830-4E□-264 833-4E2-264	1 (P)	Rc 1/2
	4 (A), 2 (B)	
	3 (R2), 5 (R1)	
	PR	

Solenoid Valve Mass g [oz.]

Basic model	Mass
830-4E1	760 [26.81] (1640 [57.85])
830-4E2	870 [30.69] (1760 [62.08])
833-4E2	850 [29.98] (1740 [61.38])

Remark: Figures in parentheses () are the mass with sub-base.

Flow Rate

830-4E1-266
830-4E2-266
833-4E2-266

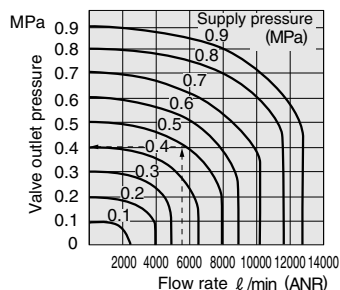

1Mpa = 145psi., 1 l /min = 0.0353ft.³/min.

How to read the graph

When the supply pressure is 0.5MPa [73psi.] and the flow rate is 5800 l /min [205ft.³/min.] (ANR), the valve outlet pressure becomes 0.4MPa [58psi.]

830 Series Solenoid Valve Order Codes



		3-position valve Valve function	Sub-base	Manual override	Wiring type
		Closed center Blank	Port size Rc1/2, side piping -264	Non-locking type manual override Blank	Grommet type Blank
		Exhaust center -13	Port size Rc3/4, side piping -266		Conduit type -37
		Pressure center -14	Port size Rc1/2, bottom piping (made to order) -284		DIN connector -39
			Port size Rc3/4, bottom piping (made to order) -286		
			● When ordering single valve units, omit this code from the order code. The single valve includes 4 mounting screws and 1 gasket.		
	Basic model				Voltage
Sub-base	5-port, 2-position single solenoid	830-4E1	-264	-37 -39	DC24V AC100V AC200V
	5-port, 2-position double solenoid	830-4E2	-266 -284 -286		
	5-port, 3-position double solenoid	833-4E2	-13, -14		

For made to order details, see p.759.

Additional Parts (To be ordered separately)

Speed controller



● For Rc1/2

● For Rc3/4

Muffler



● For Rc1/2

● For Rc3/4

Operating Principles, Major Parts and Materials

5-port, 2-position

Single solenoid

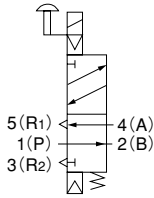

Double solenoid

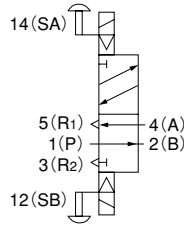

830-4E1

(De-energized)

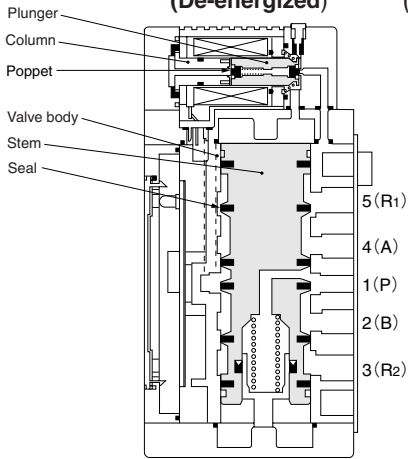

830-4E2

(De-energized condition after energizing solenoid 12(SB))

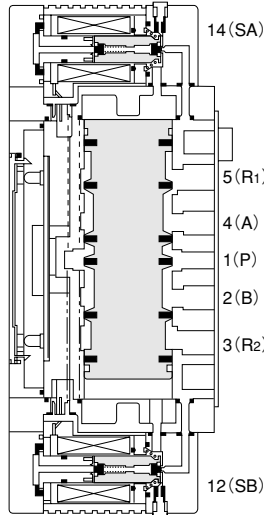

Major Parts and Materials

Parts	Materials
Body	Aluminum alloy (painted)
Stem	Aluminum alloy (anodized)
Poppet	Synthetic rubber
Seal	Urethane rubber
Plunger	Magnetic stainless steel
Column	Aluminum alloy (painted)
Sub-base	Aluminum alloy (painted)

5-port, 3-position

Closed center

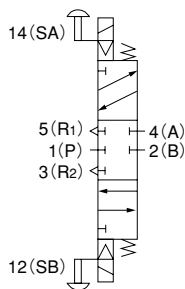

833-4E2

(Both solenoids 14(SA) and 12(SB) are de-energized.)

Exhaust center

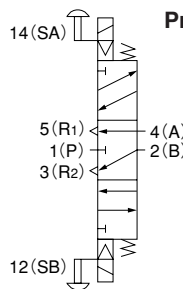

833-4E2-13

(Both solenoids 14(SA) and 12(SB) are de-energized.)

Pressure center

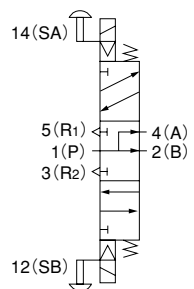

833-4E2-14

(Both solenoids 14(SA) and 12(SB) are de-energized.)

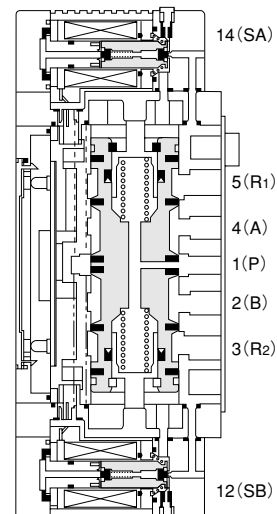
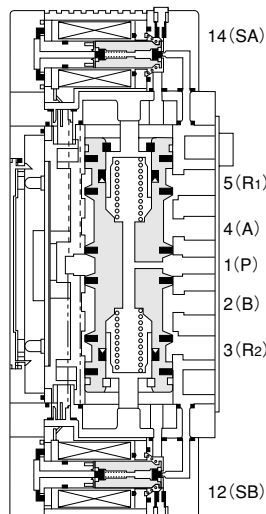
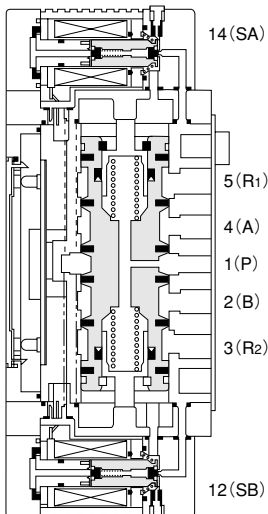

Dimensions of Solenoid Valve (mm)

830-4E1-264 (Grommet type) 830-4E1-266 (Grommet type)

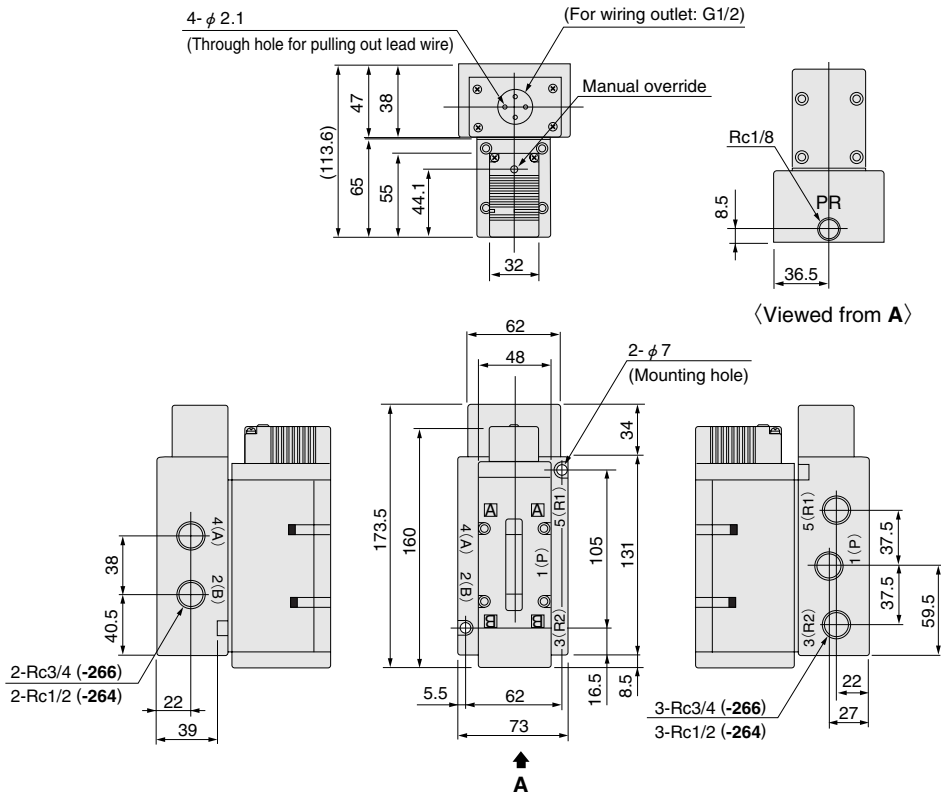

-37 (Conduit type)

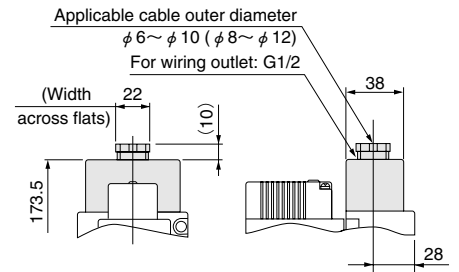
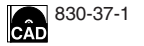

-39 (DIN connector)

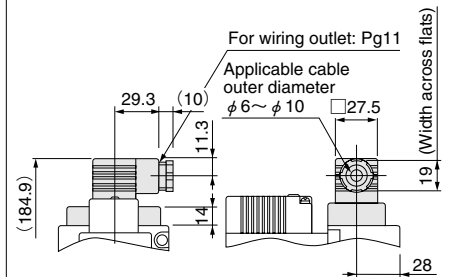
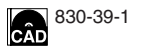

830-4E2-264 (Grommet type) 830-4E2-266 (Grommet type)

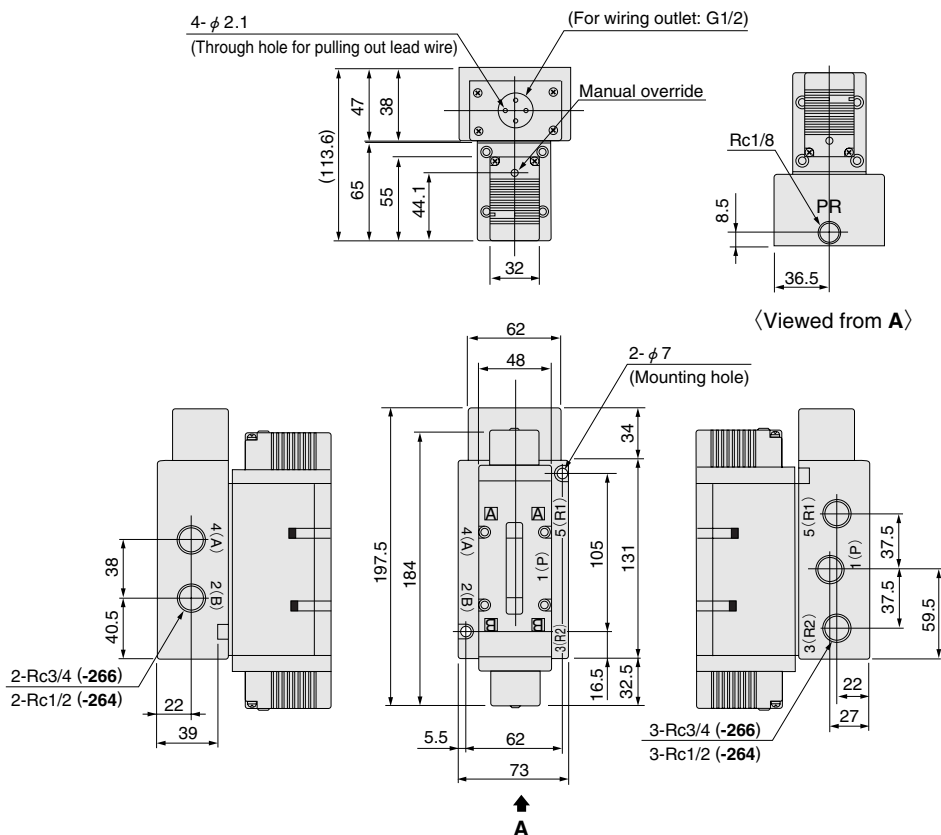

-37 (Conduit type)

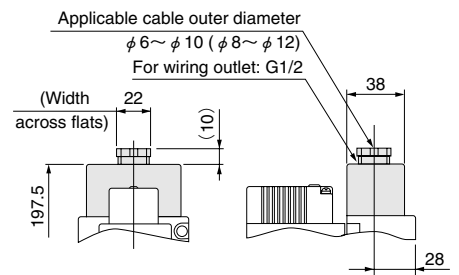
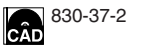

-39 (DIN connector)

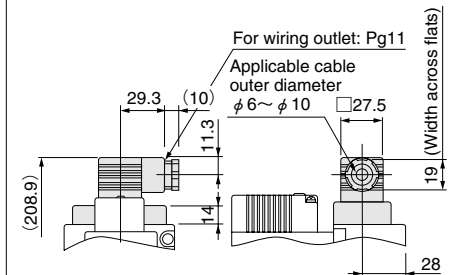
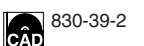

833-4E2-264 (Grommet type)
833-4E2-266 (Grommet type)

CAD 830-4E2

-37 (Conduit type)

CAD 830-37-2

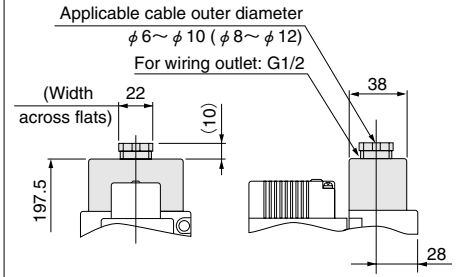
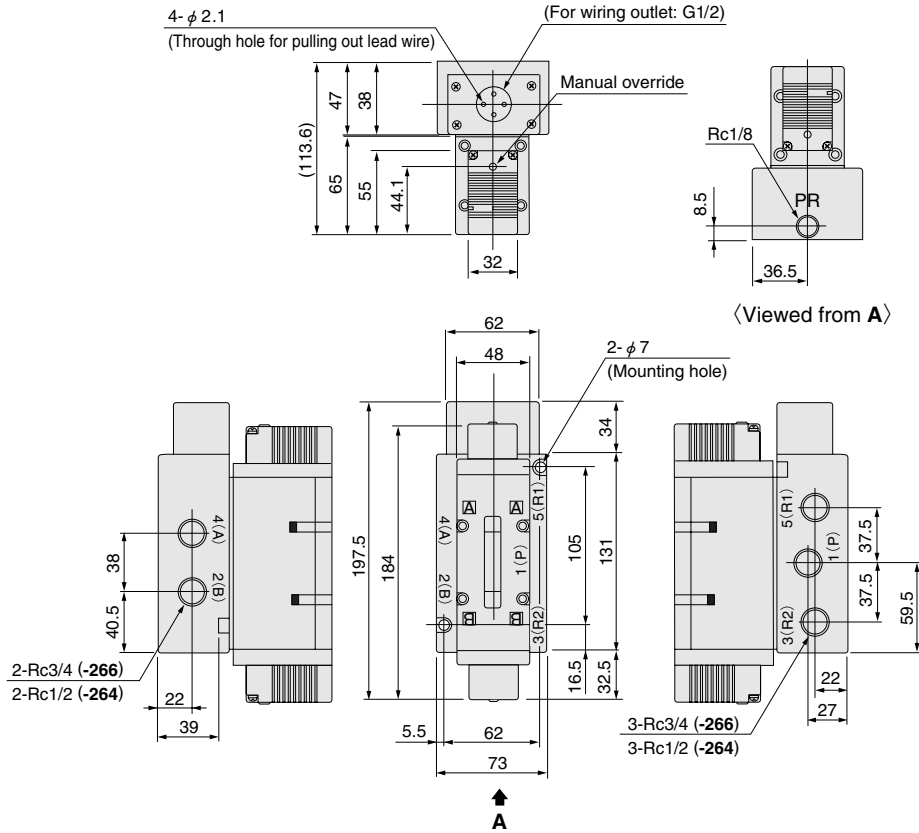

-39 (DIN connector)

CAD 830-39-2

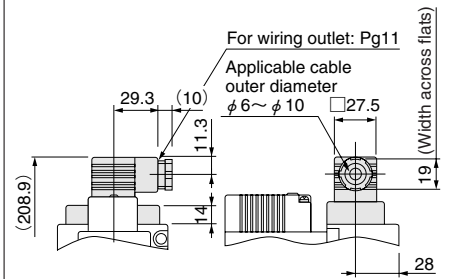

Dimensions of Additional Parts (To be ordered separately) (mm)

CAD 830-AD

● Speed controller: **SCE-04**

● Speed controller: **SCE-06**

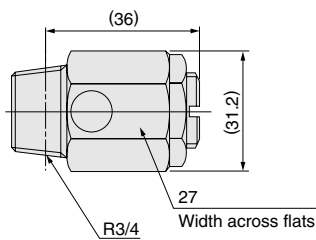
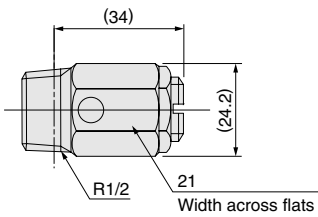

● Muffler: **KM-41**

● Muffler: **KM-6**

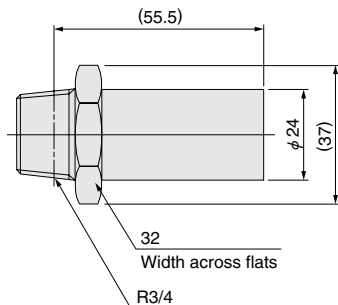
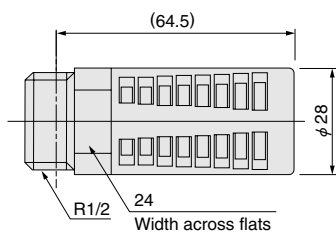

Bottom piping sub-base (Internal pilot solenoid valve)

The standard sub-base employs side piping, but the use of this sub-base enables the bottom piping. Use it when there is not enough piping space in the sub-base side-surface application. Two types of port sizes are provided for the bottom piping sub-base in each series (the PR port size, however, is Rc1/8).

430 series

Bottom piping sub-base

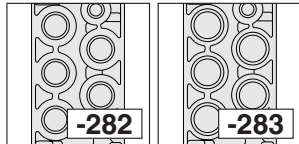

● Rc 1/4 specification ● Rc 3/8 specification

630 series

Bottom piping sub-base

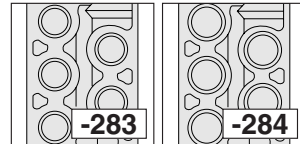

● Rc 3/8 specification ● Rc 1/2 specification

830 series

Bottom piping sub-base

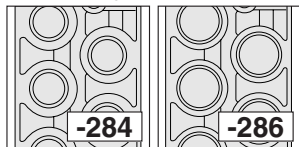

● Rc 1/2 specification ● Rc 3/4 specification

<Bottom dimensions> (mm)

● 430 series

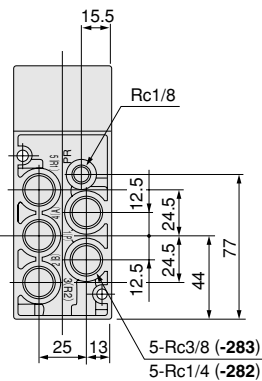

● 630 series

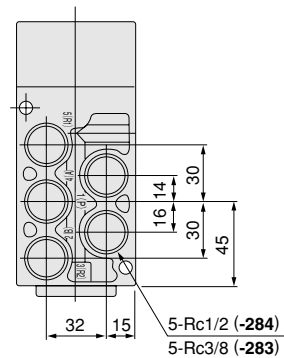

● 830 series

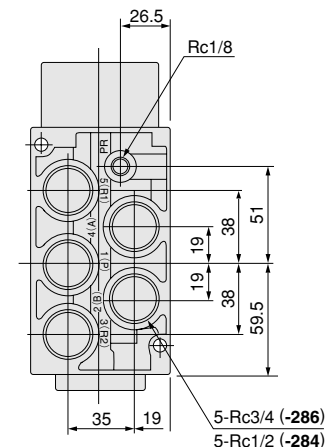

Remarks: The sub-base mass is the same as the standard one.
For the 430 series, see "Solenoid Valve Mass" on p.730, for the 630 series, see p.742, and for the 830 series, see p.754.

Bottom piping manifold (Internal pilot solenoid valve)

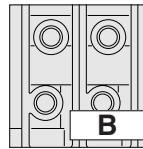

The standard manifold employs side piping, but the use of this manifold enables the bottom piping. Use it when there is not enough piping space in the manifold side-surface application.

Manifold model	Port	Piping size
430M□B	1 (P)	Rc 1/2
	4 (A), 2 (B)	Rc 1/4
	3 (R2), 5 (R1)	Rc 1/2
	PR	Rc 1/8

Manifold model	Port	Piping size
630M□B	1 (P)	Rc 1/2
	4 (A), 2 (B)	Rc 3/8
	3 (R2), 5 (R1)	Rc 1/2
	PR	Rc 1/8

<Bottom dimensions> (mm)

● 430 series

Order code: 430M□B

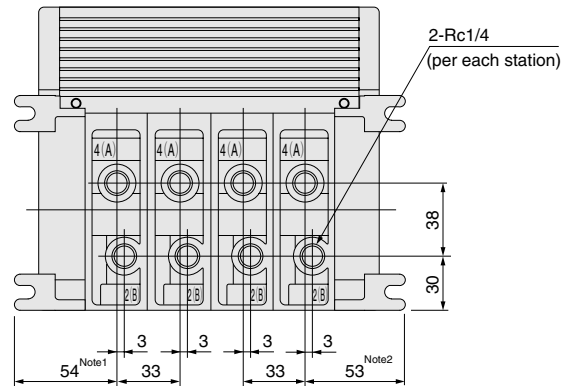

Notes: 1. With serial transmission module :-BSR, the length is 119.
2. With serial transmission module :-BSL, the length is 118.

● 630 series

Order code: 630M□B

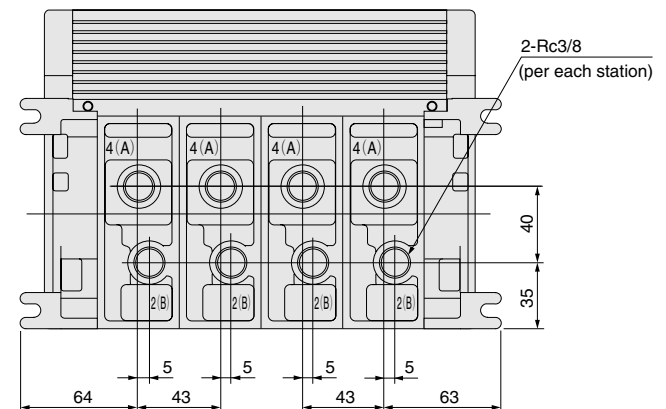

Manifold Mass

g [oz.]

Manifold model	Mass calculation of each unit (n=number of units)	Block-off plate (Model for 430 : 430-BP / Model for 630 : 630-BP)
430M□B□	(430×n)+830 [(15.17×n)+29.28]	100 [3.53]
630M□B□	(590×n)+1040 [(20.81×n)+36.68]	130 [4.59]

External pilot solenoid valve

The standard solenoid valve and sub-base is an internal pilot type. Use of this solenoid valve enables stable switching from low pressure to high pressure range (0~0.9MPa {0~9.2kgf/cm²} [0~131psi.]).

Cautions: For the external pilot solenoid valve, use the dedicated sub-base.

Use the external pilot pressures of 0.2MPa {2kgf/cm²} [29psi.] or more.

<Symbols> 432-4E1

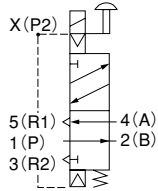

432-4E2

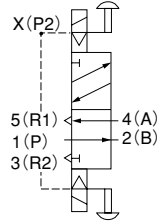

632-4E1

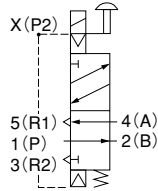

632-4E2

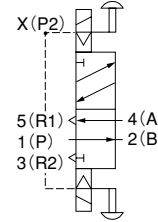

<432 sub-base dimensions> (mm)

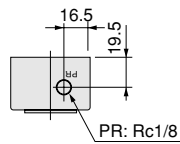
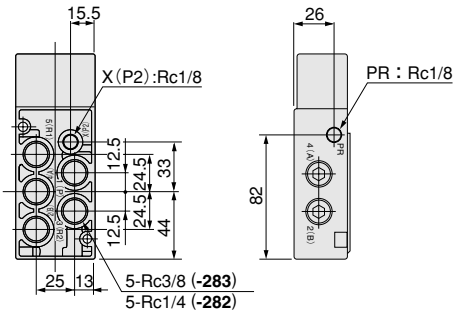

For bottom piping

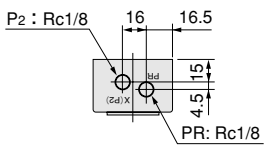

For side piping

<632 sub-base dimensions> (mm)

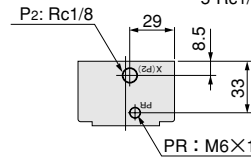
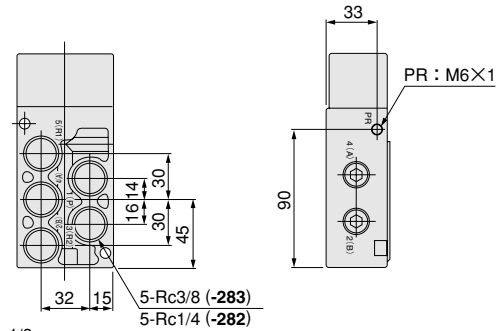

For bottom piping

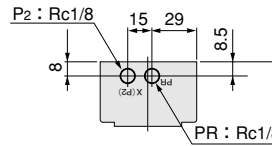

For side piping

Caution: X(P2) is a piping port for the external pilot.

The mounting dimensions for ports other than the PR and X(P2) ports are the same as the 430 and 630 series.

<Dimensions of manifold side>

432M□A
432M□B

432M□AT
432M□BT

632M□A
632M□B

632M□AT
632M□BT

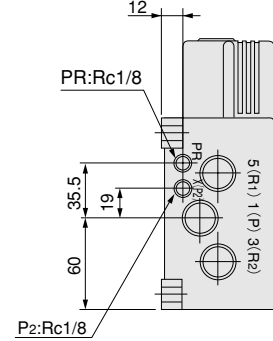
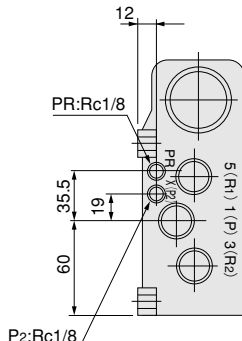
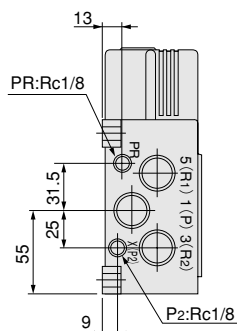
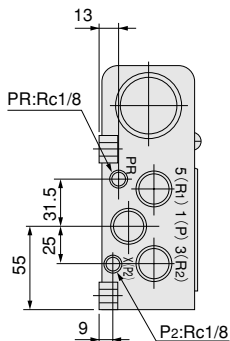

Handling Instructions and Precautions



Solenoid

Internal circuit

Voltage specification		Internal circuit	
DC24V	Single solenoid		<ul style="list-style-type: none"> ① Bridge diode (input nonpolarized element) ② LED indicator ③ Surge voltage absorption element
	Double solenoid		
AC100V AC200V	Single solenoid		<ul style="list-style-type: none"> ① Varistor (surge voltage absorption element) ② LED indicator
	Double solenoid		

Cautions: 1. Do not apply megger between the lead wires.

2. Leakage current inside the circuit could result in failure of the solenoid valve to return, or in other erratic operation. Always use at or below the allowable leakage current listed in the solenoid specifications on p.729 (or p.741, 753).
When circuit conditions, etc. cause the current leakage to exceed the allowable leakage current, consult us.

3. Since the **DC24V** specification does not have polarity, it can be used with either positive or negative common.

4. For a double solenoid, avoid energizing both solenoids simultaneously. Valve switching will not operate normally.

Wiring instructions

When using a sub-base

Grommet type

The terminal block is attached to the sub-base, as shown in the illustration below. Remove the wiring cover, and follow the internal circuitry to connect lead wires to each terminal on the terminal block.

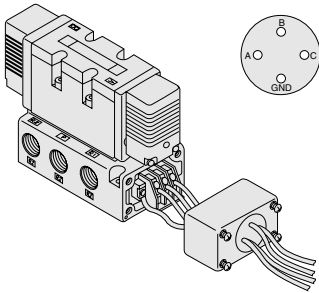

Caution: For the 4E2 type or GND, pass lead wires through wiring outlet B and the lower hole GND, and then connect them to the terminal block.

Conduit type

The applicable cable outer diameter is $\phi 6$ [0.24in.]~ $\phi 12$ [0.47in.]. When using $\phi 10$ [0.39in.]~ $\phi 12$ [0.47in.] cable, disengage the gland screw and pull out the grommet. The interior ring of the grommet is slitted for easy removal. Remove the interior ring only and leave the exterior ring in place for use.

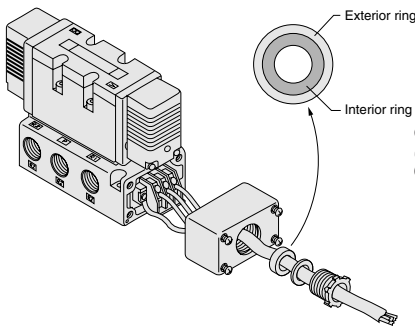

Caution: The connection to the terminal is identical to the grommet type.

DIN connector

The applicable cable outer diameter is $\phi 6$ [0.24in.]~ $\phi 10$ [0.39in.]. For wiring, remove the cover mounting screws and lift off the terminal cover from the base body. Insert a screwdriver (blade width of 4~4.5mm [0.16~0.18in.]), into the groove on the boundary between the terminal body and the terminal cover, and remove the terminal body from the terminal cover. Slip a cable gland, washer, and cable gasket over a cabtyre cable (outer diameter $\phi 6$ [0.24in.]~ $\phi 10$ [0.39in.]), insert the cable into the wiring outlet of the terminal cover, and connect the wires to each of the terminals on the terminal block.

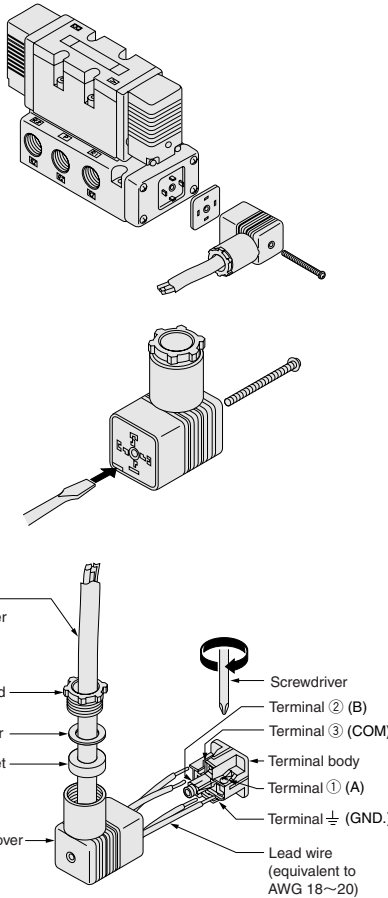

The terminal locations and terminal numbers are as shown below:

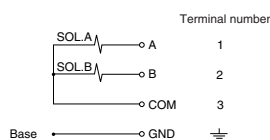
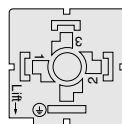

When using individual wiring manifolds (430, 630 series only)

Grommet type

"Wiring instructions" are the same as for the grommet type when using a sub-base.

Conduit type

"Wiring instructions" are the same as for the conduit type when using a sub-base.

DIN connector

"Wiring instructions" are the same as for the DIN connector when using a sub-base.

Applicable crimping terminal JIS C 2805 R type 1.25-3 or equivalent

Recommended tightening torque for each screw

Screw parts	N·cm {kgf·cm} [in·lbf]	
	Recommended tightening torque	
Terminal screw	58.8 {6.0} [5.2]	
Sub-base wiring cover mounting screw	58.8 {6.0} [5.2]	
Collective wiring manifold wiring cover mounting screw	68.6 {7.0} [6.1]	
Individual wiring manifold wiring cover mounting screw	58.8 {6.0} [5.2]	

Handling Instructions and Precautions

● When using collective wiring manifolds (430, 630 series only)

Terminal block

The terminal block is available on the manifold as shown in the illustration below. Remove the wiring cover, and following the internal circuit described above, connect lead wires to each terminal on the terminal block. The wiring cover can be removed by only loosening the wiring cover mounting screws.

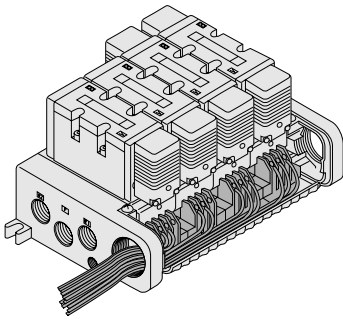

Serial transmission system

(For 430 series only)
For the usage and system configuration methods, see the relevant User's Manual.

Optional code	Applicable PC manufacturer	User's manual No. <small>Note</small>
OR	OMRON	Document: HV007
MB	Mitsubishi Electric	Document: HV006
FJ	Fuji Electric FA Components & Systems	Document: HV012
SP	SHARP	Document: V107
MS	Matsushita Electric Works	Document: V109
HT	Hitachi	Document: V108

Note : When you require a User's Manual, consult us.

Remark : The address number is placed on the solenoid at shipping.

● Conduit cap

A conduit cap is attached to a manifold's end block. Attach it to a wiring outlet that is not in use on one side.

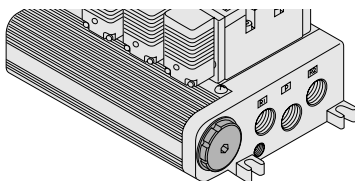

Multi connector

As shown in the illustration below, align the pin numbers on the multi connector and those on the multi connector assembly to connect them.

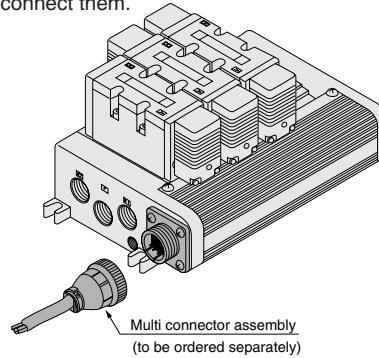

The pin locations and pin numbers are as shown below:

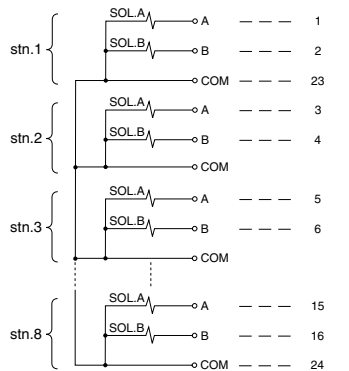
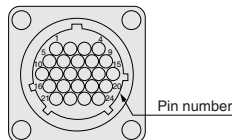

Caution: Since the DC24V specification does not have polarity, it can be used with either positive or negative common.

Additional parts (to be ordered separately)

Multi connector assembly order code

430M-AM240-A- Cable length
150 : 1500mm [59in.]
300 : 3000mm [118in.]
500 : 5000mm [197in.]

Component parts
 Plug: 206837-1 (1 pc.)
 Cable clamp: 206138-1 (1 pc.)
 Socket: 66101-2 (18 pcs.)
 Manufactured by Tyco Electronics AMP K.K.

D-sub connector

Align the pin numbers on the D-sub connector and those on the D-sub connector assembly to connect them.

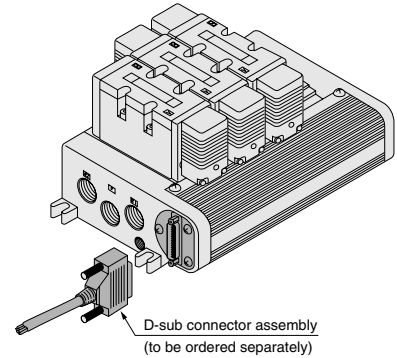

The pin locations and pin numbers are as shown below:

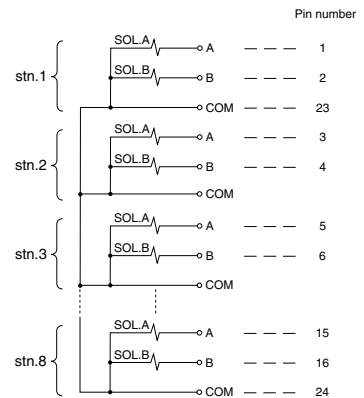
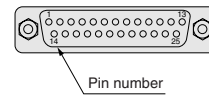

Cautions: 1. Since the DC24V specification does not have polarity, it can be used with either positive or negative common.
 2. Use M3 for the connector mounting screw.

Additional parts (to be ordered separately)

D-sub connector assembly order code
430M-AD250-A- Cable length
150 : 1500mm [59in.]
300 : 3000mm [118in.]
500 : 5000mm [197in.]

Component parts
 Plug: D type connector in accordance with MIL
 Number of pins: 25
 Connector mounting screw (molded type): M3×0.5



Plug-in

Attaching and removing valves

This series is a plug-in type valve that enables valve replacement without removing the air piping and electrical wiring.

To remove the valve body from the sub-base or manifold, loosen the valve mounting screws (4 places), and pull the valve body straight out. To mount the valve body, align the valve body plugs to the socket on the upper surface of the sub-base or manifold, fit it straight in, and then tighten the valve mounting screws. The recommended tightening torques for the valve mounting screws are as shown below.

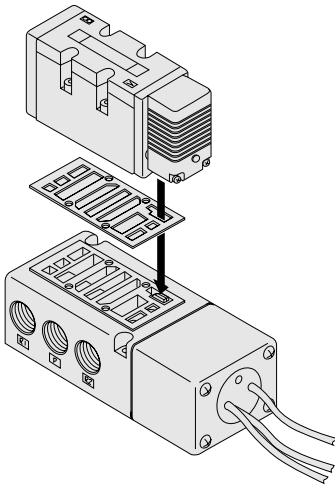

Caution: Do not attempt to remove the pilot valve.

N-cm {kgf-cm} [in-lbf]

Series name	Recommended tightening torque
430 series	105.9 {10.8} [9.37]
630 series	137.3 {14.0} [12.15]
830 series	137.3 {14.0} [12.15]



Manual override

Manual override

Using a fingertip, press the manual override all the way down to operate.

The manual override's protruding dimension is 0.7mm [0.028in.].

- For the single solenoid, the valve works the same as when in the energized state as long as the manual override is pushed down, and returns to the normal position upon release.

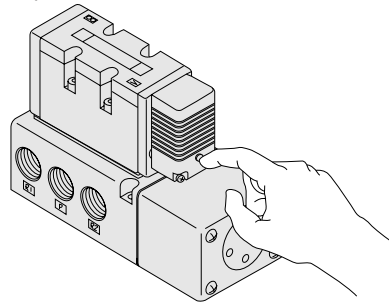

- For the double solenoid, pressing the manual override on the 14(SA) side switches the 14(SA) to enter the energized position, and the unit remains in that state even after the manual override is released. To return it to the normal position, operate the manual override on the 12(SB). This is the same for the solenoid 12(SB).

Locking type manual lever override

(430,630 series only)

- Shown in the illustration below, the locking type manual lever override is normally (when lock is released) set to 0 on the slit in the lever. To lock it, turn the lever slit 90 degrees in the direction of 1.

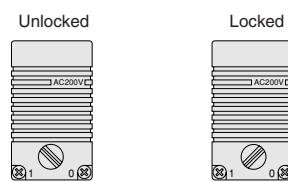

Dimensions

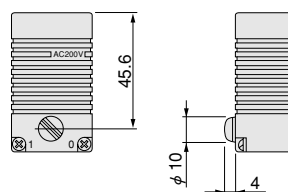

- Cautions:**
1. The 430, 630 series valves are pilot type solenoid valves. As a result, the manual override cannot switch the main valve without air supplied from the 1(P) port.
 2. Always release the lock of the locking type manual lever override before commencing normal operation.

Handling Instructions and Precautions



Manifold (430, 630 series only)

Piping

Since the 1(P), 3(R2), 5(R1) ports are on both ends of the manifold, the piping direction can be selected depending on the application.

At shipping, plugs are temporarily plugged on ports at one end, but are not firmly tightened. Regardless of which end the piping is connected to, always remove the plug, apply sealing tape or another sealing agent, and securely tighten the plug into the unused ports.

Parts ordering

When additional parts are required due to manifold increases or replacements, examine the disassembly diagram below to place orders, using the following order codes:

<Collective wiring manifold> (Wiring type is terminal block only)

No.	Parts	Order Codes	
		For 430 series	For 630 series
①	Manifold additional unit <small>Note 1</small>	430M□ <small>Note 2</small> A(B) <small>Note 3</small> S	630M□ <small>Note 2</small> A(B) <small>Note 3</small> S
②	Manifold block assembly	430MA(B) <small>Note 3</small> -MB	630MA(B) <small>Note 3</small> -MB
③	Auxiliary parts set	430MA-MHB	630MA-MHB
④	End block set	430MA-EB	630MA-EB
⑤	Wiring cover	430MA-MC□ <small>Note 4</small>	630MA-MC□ <small>Note 4</small>

Remark: The recommended tightening torque for manifold connecting bolts is 196.1N·cm {20kgf·cm} [17.4in·lbf].

Notes: 1. When ordering an additional manifold unit, first list the order code, and then enter the solenoid valve model required for the number of units. For the method of order entry, see the manifold order codes.

(Example) 430M2AS stn. 1 430-4E1 DC24V
 stn. 2 433-4E2 DC24V 1 set

When ordering additional manifold units, it is necessary to order a new wiring cover (corresponds to the total number of units).

- Enter the number of units 1~n into □. However, the total number of units on the manifold after adding new units should be 10 units or less.
- When ordering bottom piping (made to order), enter **B** instead of **A**.
- When ordering bottom piping (made to order), enter **B** instead of **A**.
- Enter the number of units 2~10 into □.

Block-off plate

To close the unused stations, use the block-off plate available as additional parts (Order code for 430: **430M-BP**, Order code for 630: **630M-BP**).

- Cautions:**
- For the 1(P) port piping, use a size that matches the manifold's piping connection port.
 - When installing piping or mufflers to the 3(R2), 5(R1) ports, ensure there will be minimum exhaust resistance.
 - On rare occasions, exhaust can interfere with other valves and actuators. In this case, let exhaust from 3(R2), 5(R1) ports on both ends.
 - When a multiple number of valves are operating simultaneously on a multi-unit manifold, or during high frequency applications, supply air from the 1(P) ports on both ends, and exhaust air from the 3(R2), 5(R1) ports on both ends.

Port isolator

When entering a port isolator order code (-MSP, -MSR, -MSD) to the manifold order code, the port isolators are installed at shipping in the space between the designated station and the station to its right (with the larger stn. number). Inserting port isolators in the 1(P) and 3(R2), 5(R1) ports between the designated station and the station to its right can isolate the air path by the port isolator position into stations with smaller station numbers and stations with larger station numbers.

- Port isolator for 1(P) port (-MSP) Can supply 2 different pressure.
- Port isolator for 3(R2), 5(R1) ports (-MSR) Can prevent exhaust air interference.
- Port isolator for 1(P), 3(R2), 5(R1) ports (-MSD) Can supply 2 different pressure, and prevent exhaust air interference.

Example: When a port isolator order code has been placed for stn.2

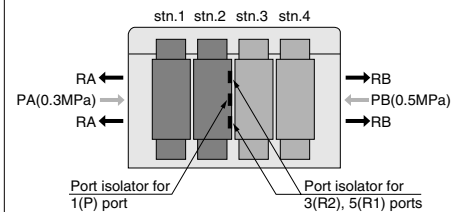

PA air is supplied to stn.1 and stn.2, while PB air is supplied to stn.3 and stn.4. Moreover, RA on stn.1 and stn.2 is exhausted from the left side, and RB on stn.3 and stn.4 is exhausted from the right side.

<Collective wiring manifold disassembly diagram>

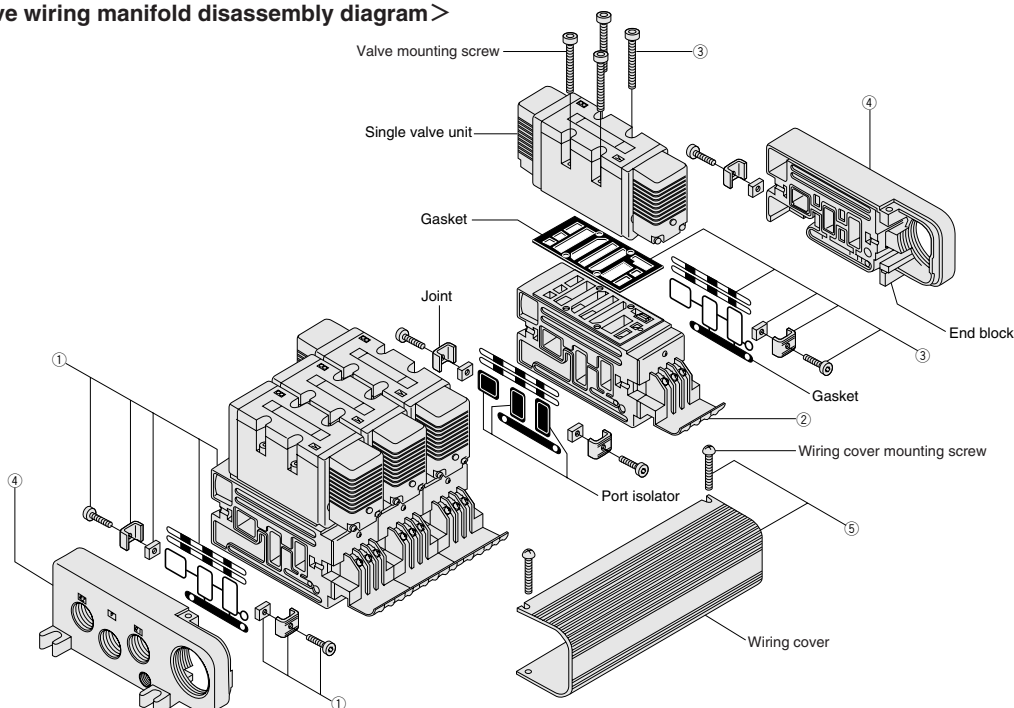

< Individual wiring manifold >

No.	Parts	Order Codes	
		For 430 series	For 630 series
⑥	Manifold additional unit ^{Note 1}	430M□ ^{Note 2} A (B) TS-□ ^{Note 3}	630M□ ^{Note 2} A(B) TS-□ ^{Note 3}
⑦	Auxiliary parts set	430MA-MHB	630M-MHB
⑧	End block set	430MAT-EB	630MAT-EB

Remark: The recommended tightening torque for manifold connecting bolts is 196.1N·cm {20kgf·cm} [17.4in·lbf].

Notes: 1. When ordering a manifold additional unit, first list the order code, and then enter the solenoid valve model required for the number of units. For the method of order entry, see the manifold order codes.

(Example) 430M2ATS-37 stn. 1 430-4E1 DC24V
 stn. 2 433-4E2 DC24V 1 set

2. Enter the number of units 1~n into □. However, the total number of units on the manifold after adding new units should be 10 units or less.

3. Enter wiring type: **Blank** (Grommet type), **-37** (Conduit type), **-39** (DIN connector) into □.

< Individual wiring manifold disassembly diagram >

