

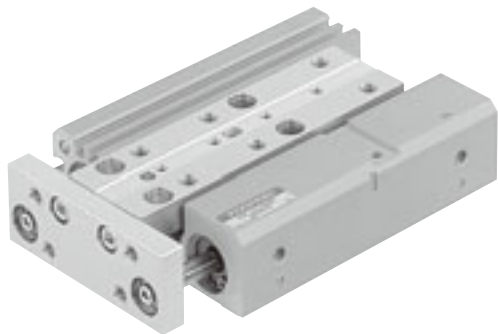

CAD drawing data catalog  
is available.



# KOGANEI

## ACTUATORS GENERAL CATALOG

# Z SLIDERS CONTENTS

Features	939
Variation Introductions	941
Handling Instructions and Precautions	942
Sizing Guide	944
Specifications	949
Order Codes	950
Inner Construction, Major Parts and Materials	952
Dimensions	954
Sensor Switches	964

Z SLIDERS



**Caution**

Before use, be sure to read the "Safety Precautions" on p. 57.

# Z SLIDERS

Introducing a low profile actuator installing a circulating type linear guide!

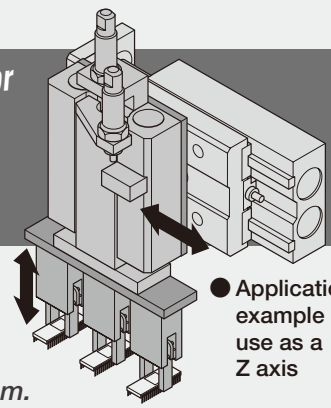

Developed mainly for movement in the Z axis direction, as reflected in the "Z Slider" name.

The thin, lightweight, and compact body offers the best match for lifters, stoppers, and pick-and-place on different levels in automated manufacturing system. Achieve accuracy, rigidity, and stroke travel linearity, in response to precision machining and requirements on assembly at the best price.

## Thin, lightweight, and low center of gravity—optimum for compact design!

A concave cross-section body—a new concept—restricts the height to the table and shortens the overall length, to achieve lightweight, compact shape, and low center of gravity. This configuration reduces the overhang distance on the Z axis.

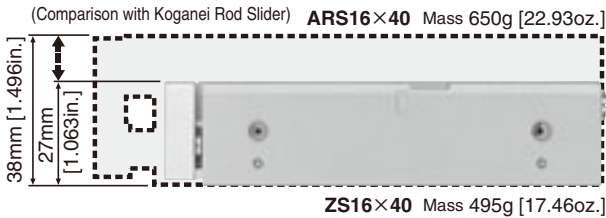

## Sensor switch can be mounted on either of 2 surfaces!

Mounting grooves are provided in the both side surfaces and top surface of the body, for mounting the embedded sensor switch (horizontal or vertical lead wire). (Optional) (The side mounted sensor switch can also be wired to the rod side.)

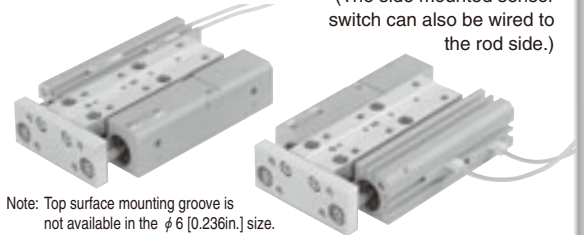

Note: Top surface mounting groove is not available in the  $\phi 6$  [0.236in.] size.

## With buffer mechanism also available!

A buffer mechanism absorbs deviation of positions or shocks at the bottom end of the stroke (extended end) due to pick-and-place in positions at different levels, or to workpiece insertion, for precise position adjustment. Spring force can be adjusted to 4 levels.

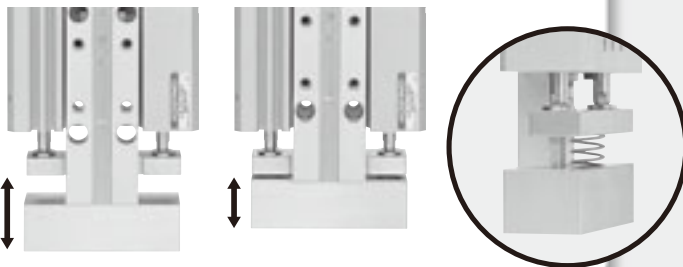

## Linear guide ensures stroke travel linearity!

A circulating type linear guide is used for improved accuracy, rigidity, and stroke travel linearity. Moreover, stainless steel for the rail and unit ensures superior corrosion-resistant, while a shortened distance between the center of the cylinder and the ball circulating section center in the guide ensures table and plate accuracy and rigidity, and improves stroke travel linearity. (A rubber bumper is standard equipment.)

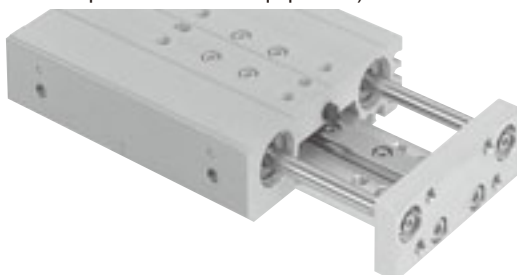

## Twin rods ensure high thrust!

Use of 2 cylinders achieves high thrust. Moreover, the retracted side thrust is increased by an average 17% larger than conventional Koganei products, for improved cycle time.



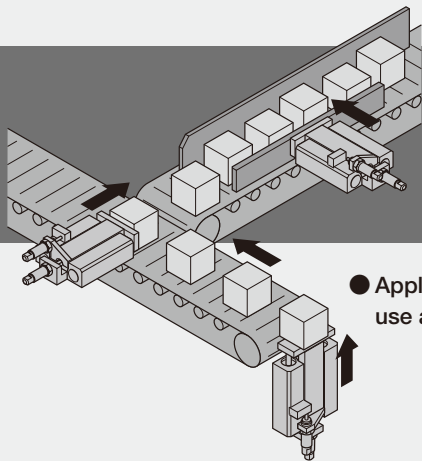

● Application example of use as a pusher and lifter

### Piping in 2 directions improves space utilization efficiency!

Piping ports are found on 2 sides—on the side surface, and also on the head side in preparation for use as a Z axis, facilitating rational piping design.

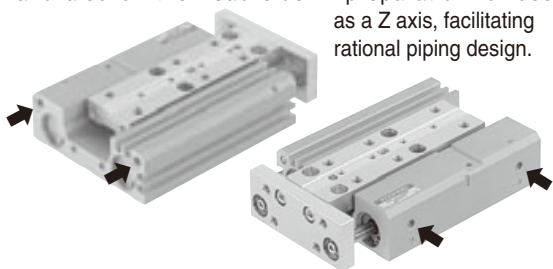

### Diverse installation and sturdy mounting brackets!

Mounting holes for securing the body in place include 4 holes in the through hole type on the table surface, and 4 tapped holes type on the back surface (the long strokes have 6 locations). Also, for mounting the workpiece in place, there are 6 threads on the table surface (4 threads for the 10-stroke type) and 4 threads on the plate surface, with larger thread sizes for sturdy mounting. Furthermore, locating dowel pin holes are provided on the body mounting surface and the table mounting surface.

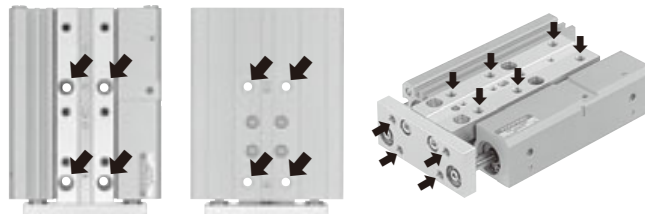

Z SLIDERS

### Two types of stroke adjustment! (When adjustment mechanism is provided)

For stroke adjustment, select from 2 types according to your applications. (Optional)

● With rubber stopper

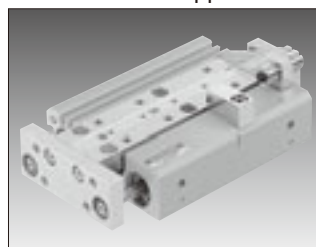

● With shock absorber

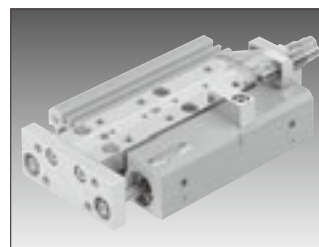

※ The extended side stroke adjustment type is not available for the 10mm stroke.  
 ※ The shock absorber cannot be used for the  $\phi 6$  size.

● Standard Z Slider compatible non-ion specification.

### Also available with end keep mechanism!

Cylinders with completely sequenced operation-type end keeps are a standard of the line-up. It prevents the cylinder from falling even if the air supply is cut off.

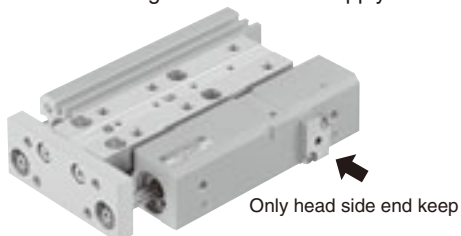

Only head side end keep

### Symmetrical cylinder saves space!

The symmetrical cylinder reverses the sensor mounting location, connection port, and stopper position to the opposite side with respect to the body center line in relation to the standard cylinder. The result is effective use of mounting space and efficient space savings.

● Standard cylinder

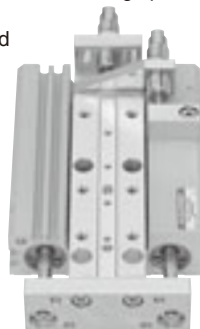

● Symmetrical cylinder



# Line-up includes 8 variations

## Standard cylinders

The standard Z Slider achieves thin and compact in Z axis direction.



## Cylinders with buffers

Built-in spring absorbs workpiece impact shocks at the extended stroke end. The spring return force can be adjusted in 4 levels.

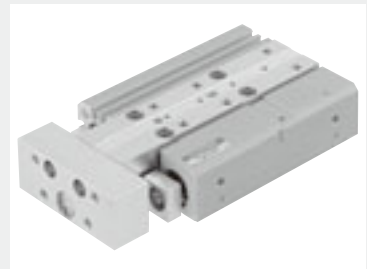

## Cylinders with end keeps

Prevent workpiece from falling down when air supply is cut off or air pressure has reduced. Available in compact at the same size as the standard type.

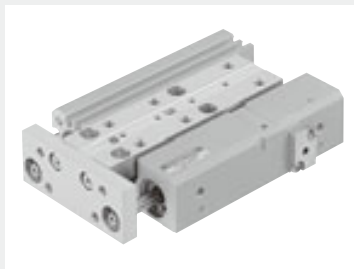

## Symmetrical cylinders

Place sensor mounting or connection port, etc., on symmetrical, opposite position, for flexible design.



**Cylinders with buffers and end keeps**  
**Symmetrical cylinders with buffers**  
**Symmetrical cylinders with end keeps**  
**Symmetrical cylinders with buffers and end keeps**

Combinations of different variations are available. (Made to order)

※ For delivery, consult us.

## Options◆Stroke adjustment mechanism

Reduces the impacts at the end of the stroke. Select either a rubber stopper or shock absorber.



Rubber stopper

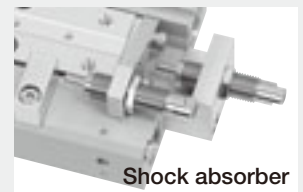

Shock absorber

## Combinations of variations and options

Model	Type	Corresponding bore size mm [in.]					Stroke adjustment <sup>Note 3</sup> (Blank: no adjusting mechanism)						Sensor switch
							Rubber stopper			Shock absorber <sup>Note 2</sup>			
							Extended side end -RSF	Retracted side end -RSR	Both ends -RS2	Extended side end -SSF	Retracted side end -SSR	Both ends -SS2	
ZS	Standard cylinder	6 [0.236]	10 [0.394]	16 [0.630]	20 [0.787]	25 [0.984]	●	●	●	●	●	●	Mountable  Embedded sensor switch  Lead wire: Horizontal lead wire type Vertical lead wire type
ZSG	Cylinder with buffer	6 [0.236]	10 [0.394]	16 [0.630]	20 [0.787]	25 [0.984]	●	●	●	●	●	●	
ZSK	Cylinder with end keep <sup>Note 1</sup>			16 [0.630]	20 [0.787]	25 [0.984]	●	—	—	●	—	—	
ZSBB	Symmetrical cylinder	6 [0.236]	10 [0.394]	16 [0.630]	20 [0.787]	25 [0.984]	●	●	●	●	●	●	
ZSGK*	Cylinder with buffer and end keep <sup>Note 1</sup>			16 [0.630]	20 [0.787]	25 [0.984]	●	—	—	●	—	—	
ZSBBG*	Symmetrical cylinder with buffer	6 [0.236]	10 [0.394]	16 [0.630]	20 [0.787]	25 [0.984]	●	●	●	●	●	●	
ZSBBK*	Symmetrical cylinder with end keep <sup>Note 1</sup>			16 [0.630]	20 [0.787]	25 [0.984]	●	—	—	●	—	—	
ZSBBGK*	Symmetrical cylinder with buffer and end keep <sup>Note 1</sup>			16 [0.630]	20 [0.787]	25 [0.984]	●	—	—	●	—	—	

※ Made to order products. For specification, dimensions and delivery, consult us.

Notes: 1. The cylinder with end keep has the head side end keep only.

2. Shock absorber is not available for cylinders with bore size of  $\phi 6$  [0.236in.].

3. Not available for both ends or extended side 10mm stroke.

# Handling Instructions and Precautions



## Selection, installation, stroke adjustment, and piping

### Selection

1. Use "Sizing Guide" on p.944 to select the load so that maximum load, allowable moment, and operating speed, etc., do not exceed the specifications limit. Maintaining values at about 80% of the allowable range is recommended. This level will constrain detrimental effects on the cylinder and guide to a minimum.
2. If using an external stopper to perform an intermediate stop, take precautions to prevent the unit from popping up due to the control circuit or external control method. Popping up can result in damage to equipment.

### Mounting

1. While any mounting direction is allowed, the mounting surface should always be flat. Twisting or bending during mounting may disturb the accuracy and may also result in air leaks or improper operation.
2. Caution should be exercised that scratches or dents on the Z slider's mounting surface may damage its flatness.
3. In applications subject to large shocks, reinforce the bolt mounting, by installing a support to the Z Slider body, for example, is recommended.
4. Do not leave scratches or dents in the areas where the piston rod contacts. It could result in damage to the seals or in air leaks.
5. In cases where the mounting bolts and nuts for the body, stroke adjusting bracket, or workpiece could become loosened by shocks or vibrations, take measures to prevent loosening. For the recommended tightening torque and the sizes of the various bolts and nuts, see the table below.

### Recommended tightening torques of the mounting bolts and nuts for the body, stroke adjusting bracket, and workpiece

Bolt size	Recommended tightening torque N · m [ft · lbf]	Nut size	Recommended tightening torque N · m [ft · lbf]
M3×0.5	1.18 [0.87]	M 6×0.75	0.85 [0.63]
M4×0.7	1.37 [1.01]	M 8×0.75	2.45 [1.81]
M5×0.8	2.84 [2.09]	M10×1.0	6.37 [4.70]
M6×1.0	4.80 [3.54]	M12×1.0	11.77 [8.68]
M8×1.25	12.0 [8.85]	—	—

### Size for the mounting bolts and nuts for the body, stroke adjusting bracket, and workpiece

Bore size mm [in.]	For mounting body		For mounting workpieces	For securing stroke adjustment		
	Through hole	Female thread		Bracket A and B Stopper B	Stopper A	Rubber stopper and shock absorber
φ 6 [0.236]	M3×0.5	M4×0.7	M4×0.7	M3×0.5	M3×0.5	M 6×0.75
φ 10 [0.394]	M3×0.5	M4×0.7	M4×0.7	M3×0.5	M4×0.7	M 8×0.75
φ 16 [0.630]	M4×0.7	M5×0.8	M5×0.8	M4×0.7	M4×0.7	M10×1.0
φ 20 [0.787]	M5×0.8	M6×1.0	M6×1.0	M5×0.8	M5×0.8	M12×1.0
φ 25 [0.984]	M6×1.0	M8×1.25	M8×1.25	M6×1.0	M6×1.0	M12×1.0

### Stroke adjustment

The optional stroke adjusting bracket set is available with either the rubber stopper type or shock absorber type. In both types, stroke adjustment within the range shown on p.949 is easy for both the extended and retracted sides (for end keep type, extended side only). For both the extended and retracted sides, rotating the stroke adjusting stopper bolt or shock absorber to the right (clockwise) shortens the stroke. After adjustment, tighten the lock nut to secure it in place. Note that the rubber stopper or shock absorber are included at shipping but not assembled.

### Piping location and operating direction

The plate and table move to the extended side when air is supplied to the B or C connection ports, and to the retracted side when air is supplied to the A or D connection ports. Note that, at shipping, the C and D connection ports are plugged.

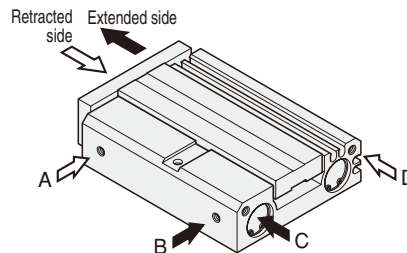

### Control circuit for the end keep cylinder

1. For control of the Z Slider with End Keep, we recommend the use of 2-position, 4-, 5-port valves. Avoid the use of control circuit with ABR connection (exhaust centers) 3-position valves that exhaust air from 2 delivery ports.
2. Always use meter-out control for speed control. Meter-in control may result in failure of the locking mechanism to release.
3. Always set the air pressure to 0.2MPa [29psi.] or more.

- Cautions:**
1. It is dangerous to supply air to a connection port on a side with a locking mechanism while the cylinder has already been exhausted, because the piston rod may suddenly extend, etc. In addition, since the lock piston could also cause galling of the lock piston and piston rod, resulting in defective operation. Always supply air to the connection port opposite the one adjacent to the locking mechanism to ensure applying back pressure.
  2. When restarting operations after air has been exhausted from the cylinder due to completion of operations or to an emergency stop, always start by supplying air to a connection port opposite the one adjacent to the locking mechanism.
  3. Connect the valve port A (NC) to the connection port on the side with the locking mechanism.



### Manual operation of locking mechanism

While the locking mechanism is normally released automatically through cylinder operations, it can also be released manually. For manual release, insert an M3×0.5 screw that has 30mm [1.18in.] screw length into the opening for the manual override, thread it in about 3 turns into the internal lock piston, and then pull up the screw. To maintain the manual override for adjustment, etc., thread the locknut onto the screw, and with the locking mechanism in a released state, tighten the locknut against the cylinder.

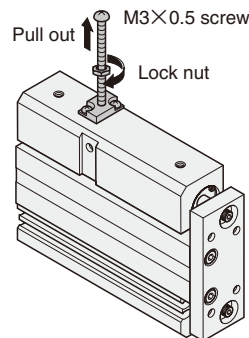

- Cautions:**
1. It is dangerous to release the lock when load (weight) is present on the piston rod, because it may cause the unintended piston rod's extension, etc. In this case, always supply air to the connection port opposite the one adjacent to the locking mechanism before releasing the locking mechanism.
  2. If the locking mechanism cannot easily be released even with manual override, it could be the result of galling of the lock piston and piston rod. In this case, supply air to the connection port opposite the one adjacent to the locking mechanism before releasing the locking mechanism.
  3. Water, oil, dust, etc., intruding through the opening for the manual override may cause defective lock or other erratic operation. If using in locations subject to dripping water, dripping oil, etc., or large amounts of dust, use a cover to protect the unit.

## Handling Instructions and Precautions



With buffer

### Operating conditions

1. For applications with buffer type, use and place the buffer mechanism side in the down side in vertical installation, or horizontal installation. Because the cylinder buffer may operate even at the buffer's full-stroke conditions depending on the load and/or speed, adjust the load and speed to avoid it in the case.
2. Do not operate the buffer mechanism while it is on the retracted side.
3. Do not apply external force on the sub-plate in the direction from the table surface to the bottom of the body, either after completion of the stroke or during the stroke movement.

### Spring return force

The spring return force incorporated into the plate with buffer can be adjusted in 4 levels. The return force at shipping is set to the lowest level (at Level 1), with the snap ring on the plate front surface retained in the closest groove to the front. To change the return force, squeeze the snap ring and move it together with the washer to the groove position for giving the desired return force, then use the snap ring to secure the washer and spring into place. When squeezing the snap ring, take caution that the washer or snap ring do not pop out due to the spring return force. In addition, be careful to avoid over-squeezing the snap ring. It could lead to damage the ring.

After adjusting the spring force, check that the snap ring is secured in the position.

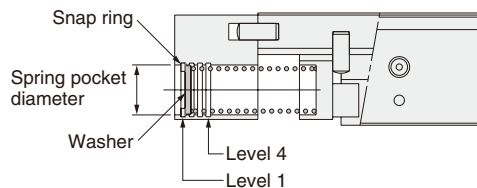
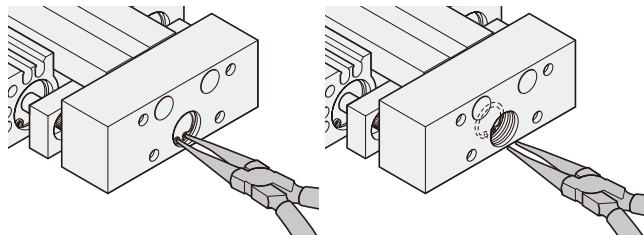

### ● Spring return force (with buffer)

Bore size (mm [in.])	Adjusting location	Spring length (mm [in.])		Spring force (N [lbf.])		Spring pocket diameter (mm [in.])
		At zero stroke	At stroke end	At zero stroke	At stroke end	
φ 6 [0.236]	Level 1	24.0 [0.945]	14.0 [0.551]	0.69 [0.155]	2.06 [0.463]	φ 7 [0.276]
	Level 2	22.0 [0.866]	12.0 [0.472]	0.96 [0.216]	2.33 [0.524]	
	Level 3	20.0 [0.787]	10.0 [0.394]	1.24 [0.279]	2.61 [0.587]	
	Level 4	18.0 [0.709]	8.0 [0.315]	1.51 [0.339]	2.88 [0.647]	
φ 10 [0.394]	Level 1	24.2 [0.953]	14.2 [0.559]	1.94 [0.436]	5.47 [1.230]	φ 8 [0.315]
	Level 2	22.2 [0.874]	12.2 [0.480]	2.65 [0.596]	6.18 [1.389]	
	Level 3	20.2 [0.795]	10.2 [0.402]	3.35 [0.753]	6.88 [1.547]	
	Level 4	18.2 [0.717]	8.2 [0.323]	4.06 [0.913]	7.59 [1.706]	
φ 16 [0.630]	Level 1	30.0 [1.181]	20.0 [0.787]	4.96 [1.115]	13.98 [3.143]	φ 12 [0.472]
	Level 2	28.0 [1.102]	18.0 [0.709]	6.77 [1.522]	15.79 [3.550]	
	Level 3	26.0 [1.024]	16.0 [0.630]	8.57 [1.927]	17.59 [3.954]	
	Level 4	24.0 [0.945]	14.0 [0.551]	10.38 [2.333]	19.40 [4.361]	
φ 20 [0.787]	Level 1	30.0 [1.181]	20.0 [0.787]	7.55 [1.697]	21.28 [4.784]	φ 14 [0.551]
	Level 2	28.0 [1.102]	18.0 [0.709]	10.30 [2.315]	24.03 [5.402]	
	Level 3	26.0 [1.024]	16.0 [0.630]	13.04 [2.931]	26.77 [6.018]	
	Level 4	24.0 [0.945]	14.0 [0.551]	15.79 [3.550]	29.52 [6.636]	
φ 25 [0.984]	Level 1	33.0 [1.299]	23.0 [0.906]	10.15 [2.282]	32.71 [7.353]	φ 17 [0.669]
	Level 2	31.0 [1.220]	21.0 [0.827]	14.66 [3.296]	37.22 [8.367]	
	Level 3	29.0 [1.142]	19.0 [0.748]	19.17 [4.309]	41.73 [9.381]	
	Level 4	27.0 [1.063]	17.0 [0.669]	23.68 [5.323]	46.24 [10.395]	

# Sizing Guide

## ● Selection procedure

## ● Calculation formula and data

## ● Selection example

### 1 Check operating conditions

Check the operating conditions, with consideration for the workpiece shape and the cylinder mounting direction, etc.

- Model
- Cylinder mounting direction
- Average cylinder speed  $V_a$  (mm/s)
- Load mass  $W$  (kg)
- Amount of overhang  $L_n$  (mm) ..... [Figure 1]
- Workpiece mounting position and shape

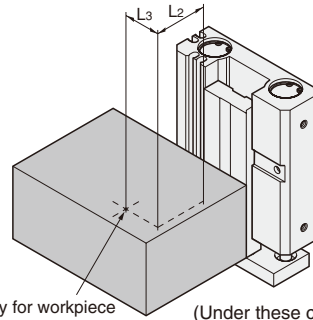

Cylinder: ZS16×40  
Vertically downward mounting  
Average cylinder speed:  
 $V_a=300$  (mm/s)  
Load mass:  
 $W=0.8$  (kg)  
 $L_2=30$  (mm)  
 $L_3=20$  (mm)

(Under these conditions,  $L_1$  is not required)

### 2 Calculate the allowable load mass

Use the allowable kinetic energy  $E_a$  (J) formula to calculate the allowable load mass  $W_a$  (kg).

$$E_a = \frac{1}{2} \times W_a \times \left( \frac{V}{1000} \right)^2$$

$$\text{or } W_a = 2 \times E_a \times \left( \frac{1000}{V} \right)^2$$

$$W_a = 2 \times 0.11 \times \left( \frac{1000}{1.5 \times 300} \right)^2 = 1.086$$

Impact speed  $V=1.5^* \times V_a$  ※Correction coefficient (as a guide)

Allowable kinetic energy  $E_a$  (J) ..... [Table 1]  $E_a=0.11$

Note: If  $W_a$  exceeds  $W_{max}$  in the Table 1, use  $W_{max}$  in the case.

### 3 Calculate the kinetic energy

Calculate the kinetic energy  $E$  (J) of the workpiece. Check that the kinetic energy of the workpiece does not exceed the allowable kinetic energy  $E_a$  (J).

$$E = \frac{1}{2} \times W \times \left( \frac{V}{1000} \right)^2$$

$$E = \frac{1}{2} \times 0.8 \times \left( \frac{1.5 \times 300}{1000} \right)^2 = 0.081$$

Impact speed  $V=1.5^* \times V_a$  ※Correction coefficient (as a guide)

Allowable kinetic energy  $E_a$  (J) ..... [Table 1]  $E_a=0.11$

Kinetic energy  $E \leq$  Allowable kinetic energy  $E_a$

The selection is satisfactory since  $E=0.081 \leq 0.11$ .

### 4 Calculate the static moment

Calculate the static moment  $M$  (N·m). Check the allowable moment  $M_a$  (N·m).

$$M = 9.8 \times W \times \frac{L_n + A_n}{1000}$$

Moment center correction value  $A_n$  ..... [Table 1]

Allowable moment  $M_a$  (N·m) ..... [Table 1]

#### Pitching

Calculate  $M_P$ .

$$M_P = 9.8 \times 0.8 \times \frac{30 + 18.5}{1000} = 0.380$$

$A_2=18.5$

$M_{aP}=6.17$

#### Yawing

Calculate  $M_Y$ .

$$M_Y = 9.8 \times 0.8 \times \frac{20 + 15}{1000} = 0.274$$

$A_3=15$

$M_{aY}=4.94$

### 5 Dynamic moment

Calculate the dynamic moment  $M_D$  (N·m). Check the allowable moment  $M_a$  (N·m).

$$M_D = 9.8 \times W \times \frac{L_n + A_n}{1000}$$

Moment center correction value  $A_n$  ..... [Table 1]

Allowable moment  $M_a$  (N·m) ..... [Table 1]

#### Pitching

Calculate  $M_{DP}$ .

$$M_{DP} = 9.8 \times 0.8 \times \frac{30 + 18.5}{1000} = 0.380$$

$A_2=18.5$

$M_{aP}=6.17$

#### Yawing

Calculate  $M_{DY}$ .

$$M_{DY} = 9.8 \times 0.8 \times \frac{20 + 15}{1000} = 0.274$$

$A_3=15$

$M_{aY}=4.94$

### 6 Check the load ratio

If the total sum of the load ratio does not exceed 1, then the selection is satisfactory.

$$\frac{W}{W_a} + \frac{M}{M_a} + \frac{M_D}{M_a} \leq 1$$

$$\frac{W}{W_a} + \frac{M_P}{M_{aP}} + \frac{M_Y}{M_{aY}} + \frac{M_{DP}}{M_{aP}} + \frac{M_{DY}}{M_{aY}}$$

$$= \frac{0.8}{1.086} + \frac{0.380}{6.17} + \frac{0.274}{4.94} + \frac{0.380}{6.17} + \frac{0.274}{4.94}$$

$$= 0.97 \leq 1$$

As shown by the above calculation, the selection is satisfactory.

# Sizing Guide

[Table 1]

Item	Code	Unit	ZS□6	ZS□10	ZS□16	ZS□20	ZS□25
Allowable kinetic energy	Ea	J	0.018	0.055	0.110	0.160	0.240
Maximum allowable load mass	Wmax	kg	6.744	16.640	22.921	41.654	63.362
Moment center correction value	A1	mm	20.0	26.0	33.0	38.0	47.0
	A2	mm	11.5	15.0	18.5	22.5	27.5
	A3	mm	11.0	12.5	15.0	18.0	22.0
Allowable moment	MaP	N·m	1.59	2.01	6.17	8.23	10.29
	MaY	N·m	0.53	1.60	4.94	6.59	8.23
	MaR	N·m	0.67	2.01	6.17	8.23	10.29

Figure 1 Overhang distance Ln (mm), and moment center correction value An (mm)

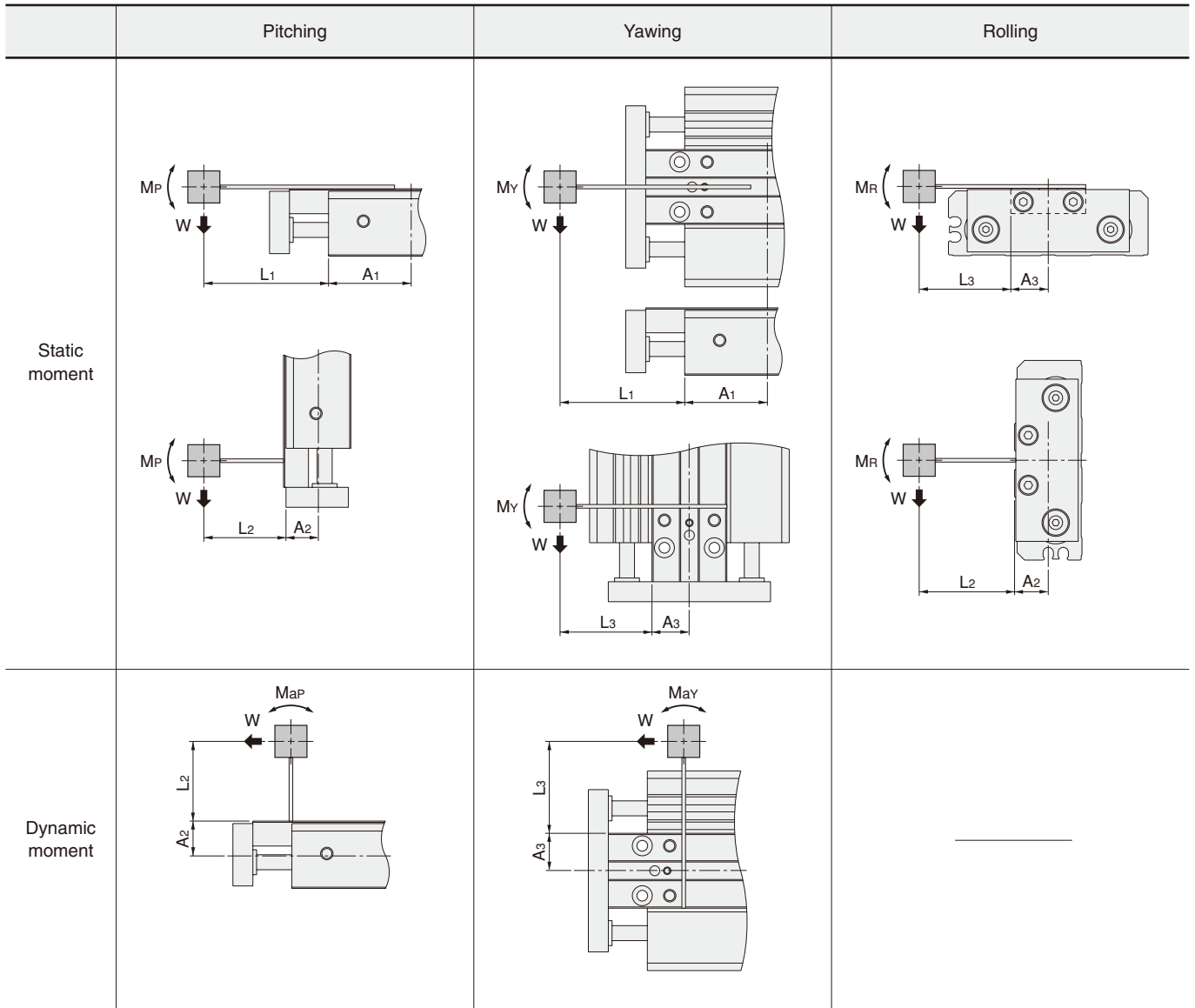

● Static moment: Moment due to load mass  
 Dynamic moment: Moment generated when stoppers collide

**Code table**

Code	Unit	Definition
V	mm/s	Impact speed
Va	mm/s	Average cylinder speed
W	kg	Load mass
Wa	kg	Allowable load mass
Wmax	kg	Maximum allowable load mass
Ln (n=1~3)	mm	Overhang distance

Code	Unit	Definition
An (n=1~3)	mm	Moment center correction value
E	J	Kinetic energy
Ea	J	Allowable kinetic energy
M (MP, MY, MR)	N·m	Static moment
MD (MDP, MDY, MDR)	N·m	Dynamic moment
Ma (MaP, MaY, MaR)	N·m	Allowable moment



# Sizing Guide

## ● Selection procedure

## ● Calculation formula and data

## ● Selection example

### 1 Check operating conditions

Check the operating conditions, with consideration for the workpiece shape and the cylinder mounting direction, etc.

- Model
- Cylinder mounting direction
- Average cylinder speed  $V'a$  [in./sec.]
- Load weight  $W'$  [lbf.]
- Amount of overhang  $L'n$  [in.] ..... [Figure 2]
- Workpiece mounting position and shape

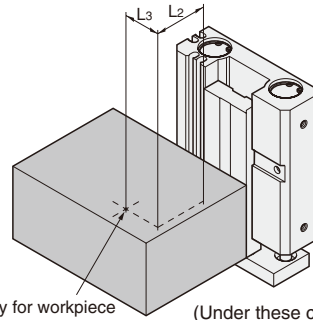

Cylinder: ZS16×40  
Vertically downward mounting  
Average cylinder speed:  
 $V'a = 11.8$  [in./sec.]  
Load weight:  
 $W' = 1.76$  [lbf.]  
 $L'_2 = 1.181$  [in.]  
 $L'_3 = 0.787$  [in.]

### 2 Calculate the allowable load weight

Use the allowable kinetic energy  $E'a$  [ft·lbf] formula to calculate the allowable load weight  $W'a$  [lbf].

$$E'a = \frac{1}{2} \times \frac{W'a}{32.2} \times \left(\frac{V'}{12}\right)^2$$

$$\text{or } W'a = 2 \times 32.2 \times E'a \times \left(\frac{12}{V'}\right)^2$$

$$W'a = 2 \times 32.2 \times 0.0811 \times \left(\frac{12}{1.5 \times 11.8}\right)^2 = 2.40$$

Impact speed  $V' = 1.5^{**} \times V'a$  ※Correction coefficient (as a guide)

Allowable kinetic energy  $E'a$  [ft·lbf] ..... [Table 2]  $E'a = 0.0811$

Note: If  $W'a$  exceeds  $W'max$  in the Table 2, use  $W'max$  in the case.

### 3 Calculate the kinetic energy

Calculate the kinetic energy  $E'$  [ft·lbf] of the workpiece. Check that the kinetic energy of the workpiece does not exceed the allowable kinetic energy  $E'a$  [ft·lbf].

$$E' = \frac{1}{2} \times \frac{W'}{32.2} \times \left(\frac{V'}{12}\right)^2$$

$$E' = \frac{1}{2} \times \frac{1.76}{32.2} \times \left(\frac{1.5 \times 11.8}{12}\right)^2 = 0.0595$$

Impact speed  $V' = 1.5^{**} \times V'a$  ※Correction coefficient (as a guide)

Allowable kinetic energy  $E'a$  [ft·lbf] ..... [Table 2]  $E'a = 0.0811$

Kinetic energy  $E' \leq$  Allowable kinetic energy  $E'a$   
The selection is satisfactory since  $E' = 0.0595 \leq 0.0811$ .

### 4 Calculate the static moment

Calculate the static moment  $M'$  [ft·lbf].  
Check the allowable moment  $M'a$  [ft·lbf].

$$M' = W' \times \frac{L'n + A'n}{12}$$

Moment center correction value  $A'n$  ..... [Table 2]

Allowable moment  $M'a$  [ft·lbf] ..... [Table 2]

#### Pitching

Calculate  $M'p$ .

$$M'p = 1.76 \times \frac{1.181 + 0.728}{12} = 0.280$$

$A'_2 = 0.728$

$M'ap = 4.551$

#### Yawing

Calculate  $M'y$ .

$$M'y = 1.76 \times \frac{0.787 + 0.591}{12} = 0.202$$

$A'_3 = 0.591$

$M'ay = 3.644$

### 5 Dynamic moment

Calculate the dynamic moment  $M'd$  [ft·lbf].  
Check the allowable moment  $M'a$  [ft·lbf].

$$M'd = W' \times \frac{L'n + A'n}{12}$$

Moment center correction value  $A'n$  ..... [Table 2]

Allowable moment  $M'a$  [ft·lbf] ..... [Table 2]

#### Pitching

Calculate  $M'dp$ .

$$M'dp = 1.76 \times \frac{1.181 + 0.728}{12} = 0.280$$

$A'_2 = 0.728$

$M'ap = 4.551$

#### Yawing

Calculate  $M'dy$ .

$$M'dy = 1.76 \times \frac{0.787 + 0.591}{12} = 0.202$$

$A'_3 = 0.591$

$M'ay = 3.644$

### 6 Check the load ratio

If the total sum of the load ratio does not exceed 1, then the selection is satisfactory.

$$\frac{W'}{W'a} + \frac{M'}{M'a} + \frac{M'd}{M'a} \leq 1$$

$$\frac{W'}{W'a} + \frac{M'p}{M'ap} + \frac{M'y}{M'ay} + \frac{M'dp}{M'ap} + \frac{M'dy}{M'ay}$$

$$= \frac{1.76}{2.40} + \frac{0.280}{4.551} + \frac{0.202}{3.644} + \frac{0.280}{4.551} + \frac{0.202}{3.644}$$

$$= 0.97 \leq 1$$

As shown by the above calculation, the selection is satisfactory.

# Sizing Guide

[Table 2]

Item	Code	Unit	ZS□6	ZS□10	ZS□16	ZS□20	ZS□25
Allowable kinetic energy	E'a	ft·lbf	0.0133	0.0406	0.0811	0.118	0.177
Maximum allowable load weight	W'max	lbf.	14.87	36.69	50.54	91.85	139.71
Moment center correction value	A'1	in.	0.787	1.024	1.299	1.496	1.850
	A'2	in.	0.453	0.591	0.728	0.886	1.083
	A'3	in.	0.433	0.492	0.591	0.709	0.866
Allowable moment	M'ap	ft·lbf	1.173	1.483	4.551	6.070	7.590
	M'ay	ft·lbf	0.391	1.180	3.644	4.861	6.070
	M'ar	ft·lbf	0.494	1.483	4.551	6.070	7.590

Figure 2 Overhang distance L'n [in.], and moment center correction value A'n [in.]

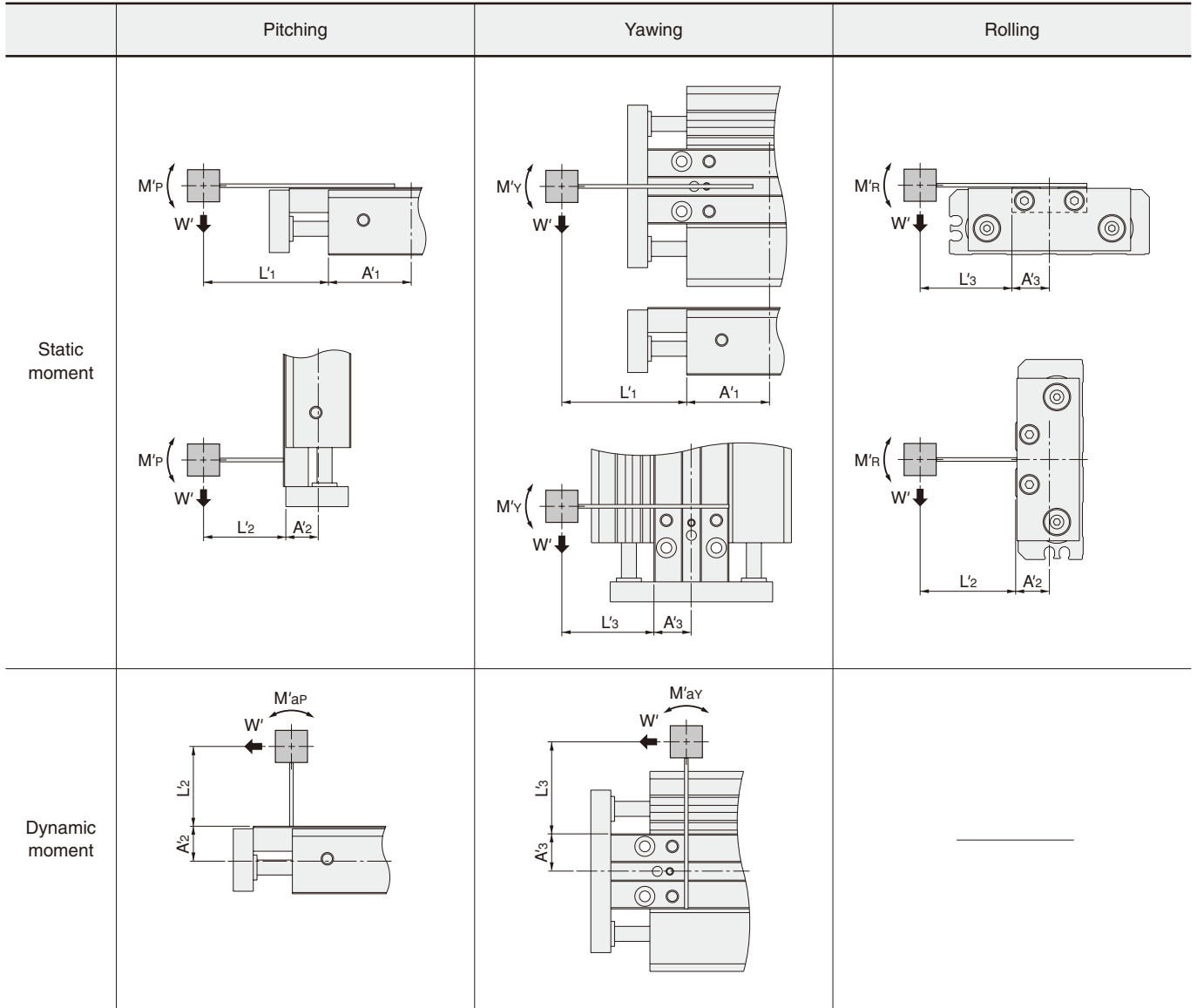

● Static moment :Moment due to load weight  
 Dynamic moment :Moment generated when stoppers collide

**Code table**

Code	Unit	Definition
V'	in./sec.	Impact speed
V'a	in./sec.	Average cylinder speed
W'	lbf.	Load weight
W'a	lbf.	Allowable load weight
W'max	lbf.	Maximum allowable load weight
L'n (n=1~3)	in.	Overhang distance

Code	Unit	Definition
A'n (n=1~3)	in.	Moment center correction value
E'	ft·lbf	Kinetic energy
E'a	ft·lbf	Allowable kinetic energy
M' (M'p, M'y, M'r)	ft·lbf	Static moment
M'b (M'bp, M'by, M'br)	ft·lbf	Dynamic moment
M'a (M'ap, M'ay, M'ar)	ft·lbf	Allowable moment

## Plate and Table Accuracy

Parallelism of the table surface and perpendicularity of the plate surface with regard to the mounting surface are shown in the diagram below.

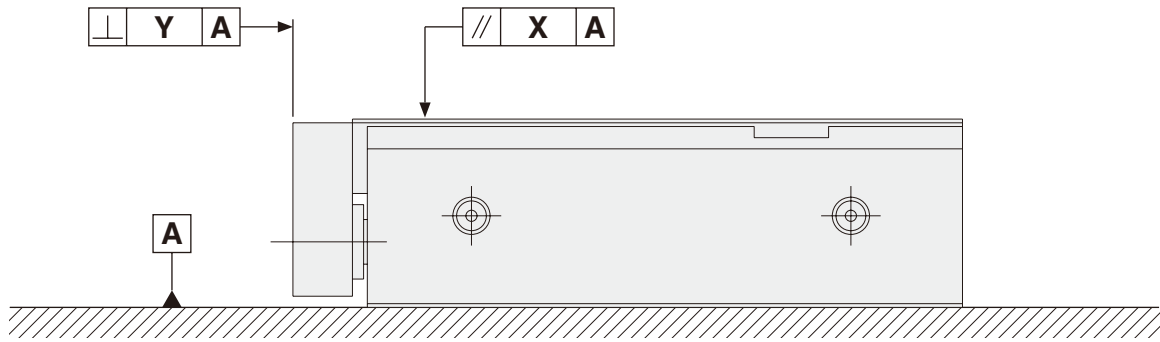

Traveling parallelism of the table with regard to the mounting surface is shown in the diagrams below.

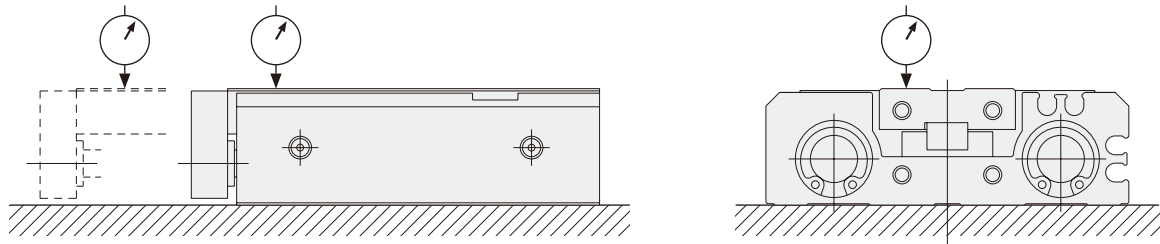

## Cylinder Thrust

When carrying a load, the load should be the maximum allowable load mass or below, and set the load ratio (load ratio =  $\frac{\text{Load}}{\text{Calculated value}}$ ), where the calculated values are shown in the table, to 50% or less when the mounting direction is vertical, and to 70% or less when the mounting direction is horizontal.

Bore size mm [in.]	Rod diameter mm [in.]	Operation direction	Pressure area mm <sup>2</sup> [in. <sup>2</sup> ]	Air pressure MPa [psi.]						
				0.15 [22]	0.2 [29]	0.3 [44]	0.4 [58]	0.5 [73]	0.6 [87]	0.7 [102]
6 [0.236]	3 [0.118]	Push side	56 [0.087]	8.4 [1.89]	11.2 [2.52]	16.8 [3.78]	22.4 [5.04]	28.0 [6.29]	33.6 [7.55]	39.2 [8.81]
		Pull side	42 [0.065]	6.3 [1.42]	8.4 [1.89]	12.6 [2.83]	16.8 [3.78]	21.0 [4.72]	25.2 [5.66]	29.4 [6.61]
10 [0.394]	5 [0.197]	Push side	157 [0.243]	23.6 [5.31]	31.4 [7.06]	47.1 [10.59]	62.8 [14.12]	78.5 [17.65]	94.2 [21.18]	109.9 [24.71]
		Pull side	117 [0.181]	17.6 [3.96]	23.4 [5.26]	35.1 [7.89]	46.8 [10.52]	58.5 [13.15]	70.2 [15.78]	81.9 [18.41]
16 [0.630]	6 [0.236]	Push side	402 [0.623]	60.3 [13.56]	80.4 [18.07]	120.6 [27.11]	160.8 [36.15]	201.0 [45.18]	241.2 [54.22]	281.4 [63.26]
		Pull side	345 [0.535]	51.8 [11.64]	69.0 [15.51]	103.5 [23.27]	138.0 [31.02]	172.5 [38.78]	207.0 [46.53]	241.5 [54.29]
20 [0.787]	8 [0.315]	Push side	628 [0.973]	94.2 [21.18]	125.6 [28.23]	188.4 [42.35]	251.2 [56.47]	314.0 [70.59]	376.8 [84.70]	439.6 [98.82]
		Pull side	527 [0.817]	79.1 [17.78]	105.4 [23.69]	158.1 [35.54]	210.8 [47.39]	263.5 [59.23]	316.2 [71.08]	368.9 [82.93]
25 [0.984]	10 [0.394]	Push side	981 [1.521]	147.2 [33.09]	196.2 [44.11]	294.3 [66.16]	392.4 [88.21]	490.5 [110.26]	588.6 [132.32]	686.7 [154.37]
		Pull side	824 [1.277]	123.6 [27.79]	164.8 [37.05]	247.2 [55.57]	329.6 [74.09]	412.0 [92.62]	494.4 [111.14]	576.8 [129.66]

# Z SLIDERS

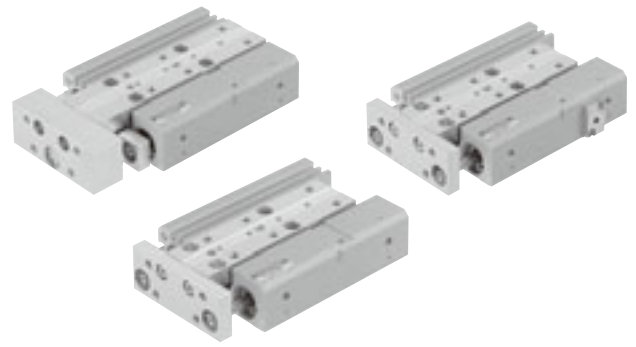

## Symbols

● Standard

● With end keep

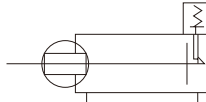
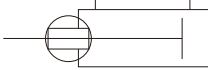

## Bore Size and Stroke

Bore size	Standard strokes	mm
		Maximum available stroke
6	10, 20, 30, 40, (50, 60, 70)	70
10	10, 20, 30, 40, 50, (60, 70, 80, 90, 100)	100
16	10, 20, 30, 40, 50, (60, 70), 80, (90, 100)	120
20	10, 20, 30, 40, 50, (60, 70), 80, (90, 100)	150
25	10, 20, 30, 40, 50, (60, 70), 80, (90, 100)	150

Note: Figures in parentheses ( ) are for made to order products.  
For specification and delivery, consult us.

## Specifications

● Standard

Model		ZS6	ZS10	ZS16	ZS20	ZS25
Item	Model					
Bore size	mm [in.]	6 [0.236]	10 [0.394]	16 [0.630]	20 [0.787]	25 [0.984]
Stroke tolerance	mm [in.]	+1 [ +0.039 ] 0 [ 0 ]				
Operation type		Double Acting Type				
Media		Air				
Operating pressure range	MPa [psi.]	0.15~0.7 [22~102]				
Proof pressure	MPa [psi.]	1.05 [152]				
Operating temperature range	°C [°F]	0~60 [32~140]				
Operating speed range	mm/s [in./sec.]	50~500 [2.0~19.7]				
Cushion	Standard	Rubber bumper				
	Options	Shock absorber				
Lubrication	Cylinder portion	Not required (If lubrication is required, use Turbine Oil Class 1 [ISO VG32] or equivalent.)				
	Guide portion	Not required (If lubrication is required, use lithium soap-based grease.)				
Repeatability <sup>Note 1</sup>	mm [in.]	±0.05 [±0.002]				
Traveling parallelism <sup>Note 2</sup>	mm [in.]	0.1 [0.004] (Up to standard maximum stroke φ6: 40mm, φ10: 50mm, φ16, 20, 25: 80mm)				
Parallelism of table top surface <sup>Note 2</sup>	mm [in.]	0.2 [0.008] (Exceeds the standard maximum stroke, up to the maximum available stroke)				
Perpendicularity of plate surface <sup>Note 2</sup>	mm [in.]	0.2 [0.008] (Exceeds the standard maximum stroke, up to the maximum available stroke)				
Stroke adjusting range <sup>Note 3</sup>	Rubber stopper retracted side	-5~0 [-0.197~0]				
	Rubber stopper extended side	-12~0 [-0.472~0]	-11~0 [-0.433~0]	-14~0 [-0.551~0]	-13~0 [-0.512~0]	-17~0 [-0.669~0]
	Shock absorber retracted side	—	-5~0 [-0.197~0]	-11~0 [-0.433~0]	-10~0 [-0.394~0]	-7~0 [-0.276~0]
	Shock absorber extended side	—	-11~0 [-0.433~0]	-19~0 [-0.748~0]	-18~0 [-0.709~0]	-17~0 [-0.669~0]
Maximum allowable load mass	kg [lb.]	6.7 [14.8]	16.6 [36.6]	22.9 [50.5]	41.7 [91.9]	63.4 [139.8]
Port size		M5×0.8			Rc1/8	

Notes: 1. For shock absorber with stroke adjusting bracket type. (Not available for φ6 [0.236in.]

2. The datum is the cylinder body mounting surface parallel to the table, and measured when no load and air pressure are applied.

3. For unit with stroke adjusting bracket. (Shock absorber type is not available for φ6 [0.236in.]

● Z slider with buffer

Model		ZSG6	ZSG10	ZSG16	ZSG20	ZSG25
Item	Model					
Bore size	mm [in.]	6 [0.236]	10 [0.394]	16 [0.630]	20 [0.787]	25 [0.984]
Operating speed range	mm/s [in./sec.]	50~500 [2.0~19.7] (At horizontal: 50~300 [2.0~11.8])				
Buffer stroke	mm [in.]	10 [0.394] MAX.				

Remarks: 1. For specifications not specified with-buffer Z sliders, use the standard specifications.

2. If using Z slider with-buffer specification, see the Handling Instructions and Precautions on p.943.

3. For Z slider with-buffer type stroke and spring force, etc., see the table on p.943.

Note that the spring force is set to the lowest level at shipping.

● Z slider with end keep

Model		ZSK16	ZSK20	ZSK25
Item	Model			
Bore size	mm [in.]	16 [0.630]	20 [0.787]	25 [0.984]
Operating pressure range	MPa [psi.]	0.2~0.7 [29~107]		
Maximum holding force at end keep	N [lbf.]	96 [21.6]	151 [33.9]	235 [52.8]
Backlash at end keep	mm [in.]	1 [0.039] MAX.		

Remarks: 1. For specifications not specified with-end-keep Z sliders, use the standard specifications.

2. If using Z slider with-end-keep specification, see the Handling Instructions and Precautions on p.942.

3. The operating life at maximum holding force is 0.5million cycles.

# Shock Absorber Specifications

Item	Model	KSHA5×5-D	KSHA6×8-F	KSHA7×8-G	KSHA7×8-K
Applicable cylinder		ZS10	ZS16	ZS20	ZS25
Maximum absorption <sup>Note</sup>	J [ft·lbf]	1.0 [0.74]	2.9 [2.14]	3.9 [2.88]	5.9 [4.35]
Absorbing stroke	mm [in.]	5 [0.197]		8 [0.315]	
Maximum impact speed	m/s [ft./sec.]		1.0 [3.28]		
Maximum operating frequency	cycle/min	60		30	
Spring return force	N [lbf.]	3.9 [0.88]		6.5 [1.46]	
Angle variation		1° or less		3° or less	
Operating temperature range	°C [°F]		0~60 [32~140]		
Mass	g [oz.]	7 [0.25]	20 [0.71]		28 [0.99]

Note: Do not exceed the Z Slider maximum speed, even when it is within the shock absorber's absorption range.

- Remarks: 1. Do not loosen the small screw on the rear end of the shock absorber. The oil inside will leak out, which will fail the function of the shock absorber.  
 2. The life of shock absorber may vary from the Z Slider, depending on its operating conditions.  
 3. For details about the shock absorber, see the General Catalog of Air Treatment, Auxiliary, and Vacuum.

## Order Codes

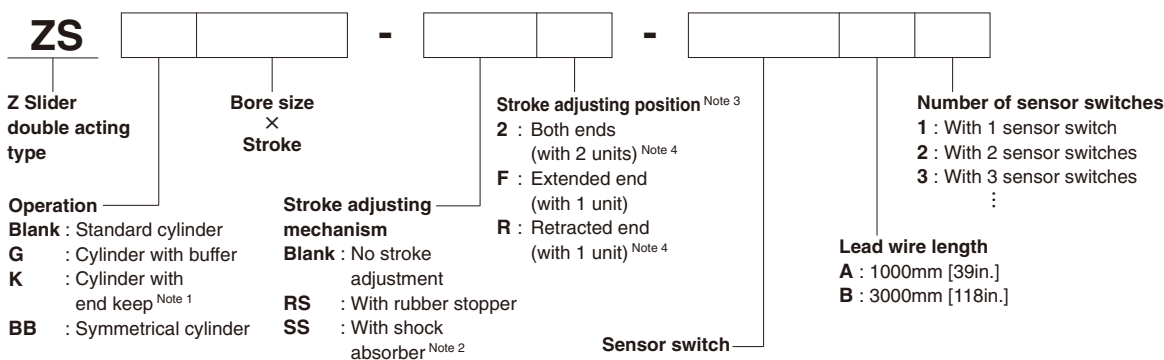

- Notes: 1. The end keep mechanism is available in  $\phi$  16~25 head side only.  
 2. Not mountable on the  $\phi$  6 size.  
 3. Not available with both-end and extended side 10mm stroke cylinders.  
 4. For cylinders with end keep, stroke adjustment cannot be performed on the retracted side.  
 5. The lead wire of sensor switches is a vertical type.

- Horizontal lead wire DC5~28V, AC85~115V
  - Horizontal lead wire DC10~28V, AC85~115V
  - Vertical lead wire<sup>Note 5</sup> DC5~28V, AC85~115V
  - Vertical lead wire<sup>Note 5</sup> DC10~28V, AC85~115V
  - Horizontal lead wire DC10~28V
  - Horizontal lead wire DC4.5~28V
  - Vertical lead wire<sup>Note 5</sup> DC10~28V
  - Vertical lead wire<sup>Note 5</sup> DC4.5~28V
- For details of sensor switches, see p.1544.

## Order codes for options only

### ● Stroke adjusting bracket set<sup>Note 4</sup>

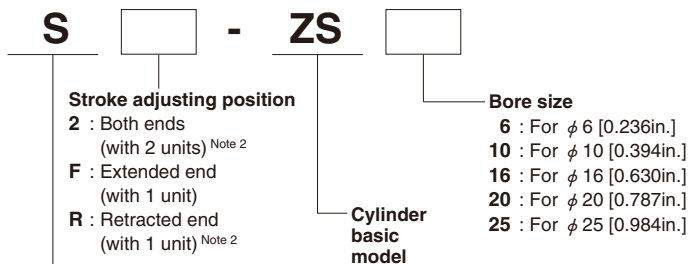

### Stroke adjusting bracket set<sup>Note 1</sup>

- Notes: 1. Extended side stroke adjustment cannot be performed on the 10mm stroke.  
 2. For cylinders with end keep, stroke adjustment cannot be performed on the retracted side.  
 3. For the contents of a set, see the table to the right.  
 4. The sets do not include a shock absorber or rubber stopper.

### ● Shock absorber single unit

Bore size	Shock absorber model
$\phi$ 6 [0.236in.]	—
$\phi$ 10 [0.394in.]	KSHA5×5-D
$\phi$ 16 [0.630in.]	KSHA6×8-F
$\phi$ 20 [0.787in.]	KSHA7×8-G
$\phi$ 25 [0.984in.]	KSHA7×8-K

- Remarks: 1. For details of the shock absorbers, see "Shock Absorbers KSHA Series" in the General Catalog of Air Treatment, Auxiliary, Vacuum.  
 2. The set consists of the shock absorber body and mounting nuts.

### Set contents

Item	Model	S2	SF	SR	pc.
Bracket A		1	1	—	
Bracket A mounting bolt		2	2	—	
Bracket B		1	—	1	
Bracket B mounting bolt		2	—	2	
Stopper A		1	1	—	
Stopper A mounting bolt		1	1	—	
Stopper B		1	1	1	
Stopper B mounting bolt		—	—	2	

### ● Rubber stopper single unit

Bore size	Rubber stopper model
$\phi$ 6 [0.236in.]	CRK570
$\phi$ 10 [0.394in.]	CRK571
$\phi$ 16 [0.630in.]	CRK572
$\phi$ 20 [0.787in.]	CRK573
$\phi$ 25 [0.984in.]	CRK574

Remark: The set consists of the rubber stopper body and mounting nuts.

## Options (Stroke Adjusting Mechanism)

**Caution:** When mounting the stroke adjusting bracket, use the recommended tightening torque on p.942.

Parts names are as shown below.

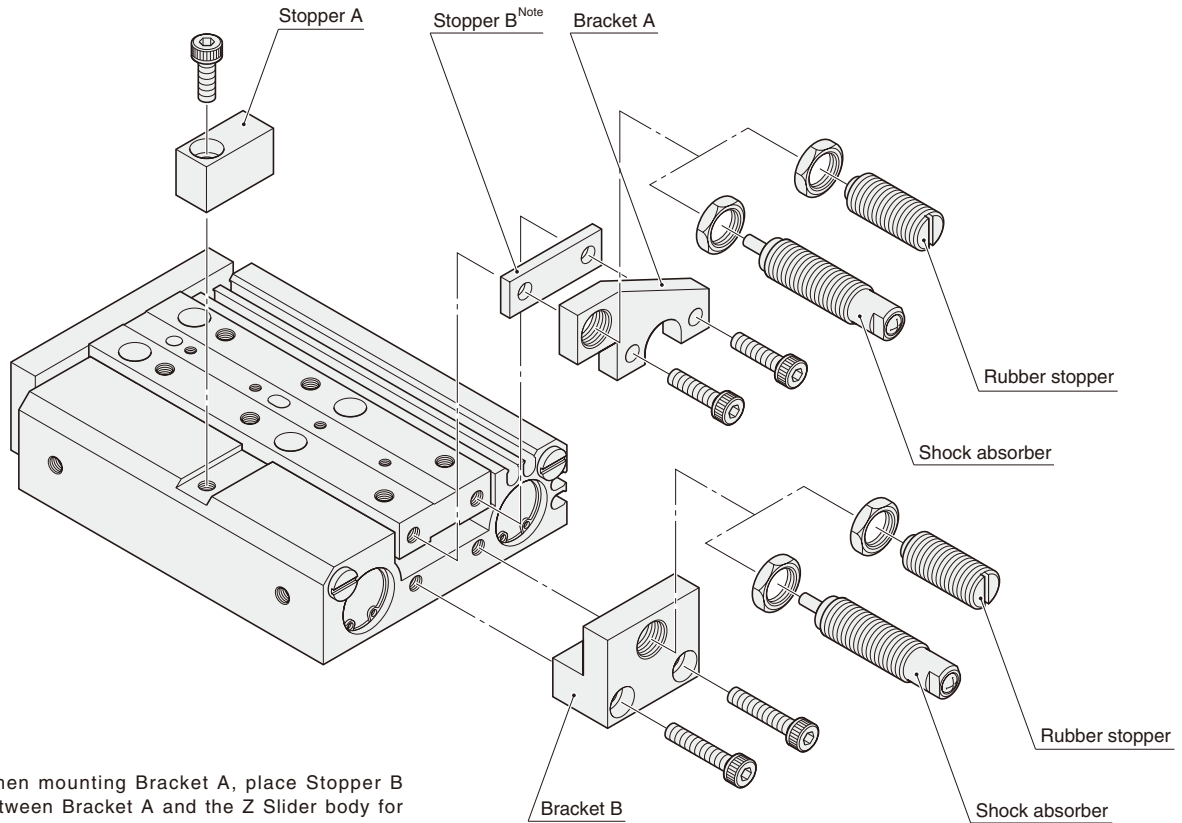

Note: When mounting Bracket A, place Stopper B between Bracket A and the Z Slider body for assembly.

Remark: When assembling Stopper B and Brackets A and B, assemble carefully to avoid interference between parts.

## Mass

### ● Body mass

Bore size mm [in.]	Zero stroke mass	Additional mass for each 10mm [0.394in.]	Additional mass of buffer	g [oz.]	
				Additional mass of end keep	
φ 6 [0.236]	85 [3.00]	20 [0.71]	26 [0.92]	—	
φ 10 [0.394]	170 [6.00]	29 [1.02]	37 [1.31]	—	
φ 16 [0.630]	323 [11.39]	43 [1.52]	79 [2.79]	20 [0.71]	
φ 20 [0.787]	577 [20.35]	67 [2.36]	110 [3.88]	26 [0.92]	
φ 25 [0.984]	973 [34.32]	94 [3.32]	172 [6.07]	45 [1.59]	

### ● Additional mass for options

Bore size mm [in.]	Additional mass of stroke adjusting bracket			Additional mass of 1 adjusting bolt	Additional mass of 1 shock absorber	Additional mass of 1 sensor switch	
	-□S2	-□SF	-□SR			Lead wire 1000mm [39in.]	Lead wire 3000mm [118in.]
	φ 6 [0.236]	23 [0.81]	16 [0.56]			10 [0.35]	4 [0.14]
φ 10 [0.394]	41 [1.45]	29 [1.02]	17 [0.60]	8 [0.28]	7 [0.25]	15 [0.53]	35 [1.23]
φ 16 [0.630]	79 [2.79]	56 [1.98]	30 [1.06]	15 [0.53]	20 [0.71]		
φ 20 [0.787]	124 [4.37]	89 [3.14]	45 [1.59]	21 [0.74]	28 [0.99]		
φ 25 [0.984]	189 [6.67]	128 [4.51]	75 [2.65]	25 [0.88]	28 [0.99]		

### Calculation example) For ZSGK16×40-RSF-ZE101A2.

$$323 + 43 \times 4 + 79 + 20 + 56 + 15 + 15 \times 2 = 695\text{g [24.51oz.]}$$

# Inner Construction of Standard Cylinder

Diagrams show  
 $\phi$  16 [0.630in.]

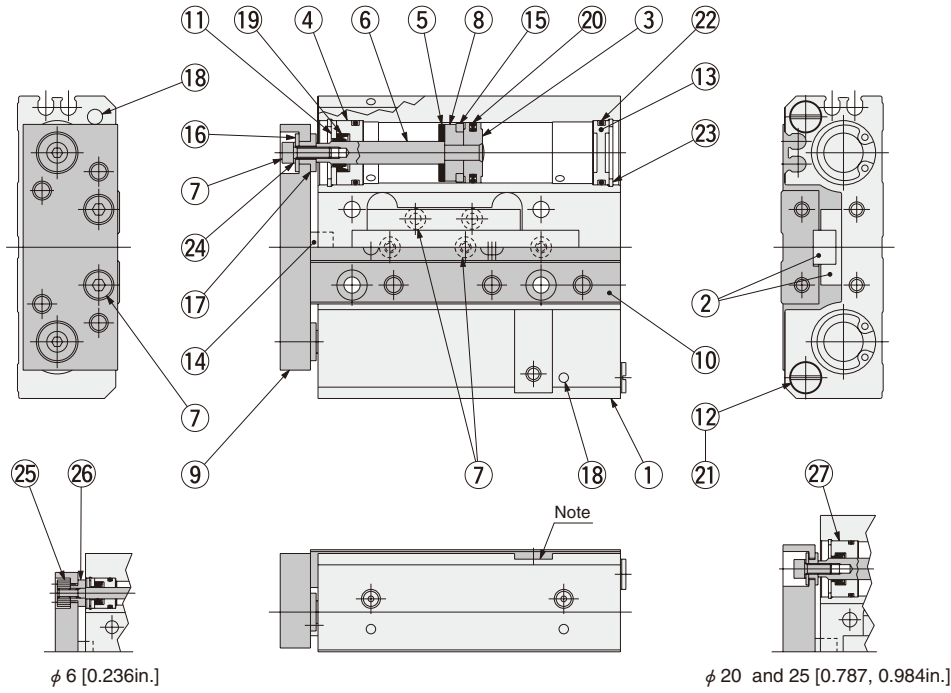

Note: This concave portion is not available for stroke 10.

## Major Parts and Materials

No.	Parts	Materials	Remarks
①	Body	Aluminum alloy (anodized)	
②	Guide	Stainless steel	
③	Piston	Aluminum alloy (special rust prevention treatment)	
④	Housing	Aluminum alloy (special wear-resistant treatment)	Only $\phi$ 6 [0.236in.]~ $\phi$ 16 [0.630in.]
⑤	Bumper A	Synthetic rubber (NBR)	
⑥	Piston rod	Stainless steel	Hard chrome plated for only $\phi$ 16 [0.236in.]~ $\phi$ 25 [0.984in.]
⑦	Bolt	Stainless steel or steel (nickel plated)	
⑧	Support	Aluminum alloy (special rust prevention treatment)	$\phi$ 6 [0.236in.]: Aluminum alloy (anodized)
⑨	Plate	Special aluminum alloy (anodized)	
⑩	Table	Aluminum alloy (anodized)	
⑪	Seal holder	Aluminum alloy (special rust prevention treatment)	Only $\phi$ 6 [0.236in.]~ $\phi$ 16 [0.630in.]
⑫	Plug	Mild steel	$\phi$ 6 [0.236in.]~ $\phi$ 16 [0.630in.]: Nickel plated $\phi$ 20 [0.787in.], $\phi$ 25 [0.984in.]: Zinc plated
⑬	End plate	Plastic	$\phi$ 6 [0.236in.]: Aluminum alloy (anodized)
⑭	Bumper B	Synthetic rubber (NBR)	$\phi$ 25 [0.984in.]: Urethane
⑮	Magnet	Sintered alloy magnet	
⑯	Bolt retainer	Mild steel (nickel plated)	
⑰	Sleeve	Mild steel (nickel plated)	
⑱	Steel ball	Stainless steel	
⑲	Rod seal	Synthetic rubber (NBR)	
⑳	Piston seal	Synthetic rubber (NBR)	
㉑	Seal	Synthetic rubber (NBR)	Baked on mild steel (only $\phi$ 6 [0.236in.]~ $\phi$ 16 [0.630in.]
㉒	O-ring	Synthetic rubber (NBR)	
㉓	Snap ring	Mild steel (nickel plated)	
㉔	Washer	Steel (nickel plated)	Only $\phi$ 6 [0.236in.]~ $\phi$ 25 [0.984in.]
㉕	Joint nut A	Mild steel (nickel plated)	
㉖	Joint nut B	Mild steel (nickel plated)	
㉗	Rod cover	Aluminum alloy (special wear-resistant treatment)	Only $\phi$ 20 [0.787in.] and $\phi$ 25 [0.984in.]

## Inner Construction of Cylinder with Buffer and End Keep Mechanism

Diagrams show  
 $\phi$  16 [0.630in.].

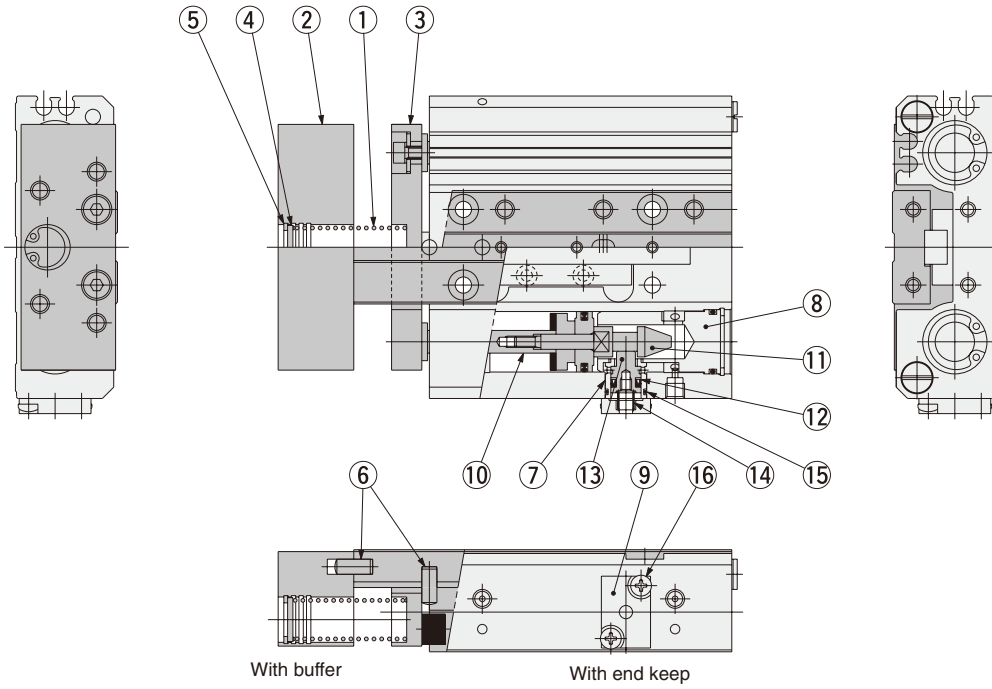

### Major Parts and Materials

No.	Parts	Materials
①	Buffer spring	Stainless steel
②	Plate	Aluminum alloy (anodized)
③	Sub-plate	Special aluminum alloy (anodized)
④	Washer	Aluminum alloy (anodized)
⑤	Snap ring	Mild steel (nickel plated)
⑥	Pin	Stainless steel (heat treated)
⑦	Sleeve	Aluminum alloy (anodized)
⑧	Head cover	Aluminum alloy (anodized)

No.	Parts	Materials
⑨	Cover	Aluminum alloy (anodized)
⑩	Piston rod	Stainless steel (hard chrome plated)
⑪	Lock end	Steel (heat treated)
⑫	Lock piston seal	Synthetic rubber (NBR)
⑬	Lock piston	Steel (heat treated)
⑭	Lock spring	Stainless steel
⑮	O-ring	Synthetic rubber (NBR)
⑯	Screw	Mild steel (zinc plated)

## Inner Construction of Cylinder with Stroke Adjusting Mechanism

Diagrams show  
 $\phi$  16 [0.630in.].

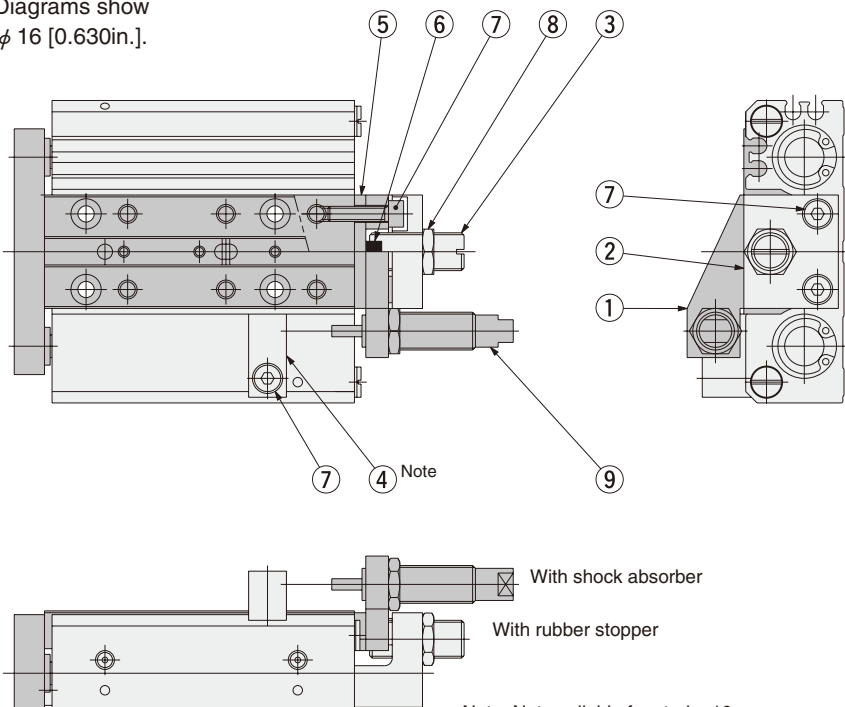

### Major Parts and Materials

No.	Parts	Materials
①	Bracket A	Mild steel (nickel plated)
②	Bracket B	Aluminum alloy (anodized)
③	Adjusting bolt	Mild steel (nickel plated)
④	Stopper A	Steel (nickel plated)
⑤	Stopper B	Steel (nickel plated)
⑥	Bumper	Synthetic rubber (NBR)
⑦	Bolt	Stainless steel, steel (nickel plated)
⑧	Nut	Mild steel (zinc plated)
⑨	Shock absorber	—

Note: Not available for stroke 10mm.  
 Remark: The combinations shown here are  
 not available in order code.



# φ 6 [0.236in.] Dimensions (mm)

## ● Standard cylinder



ZS6 ×

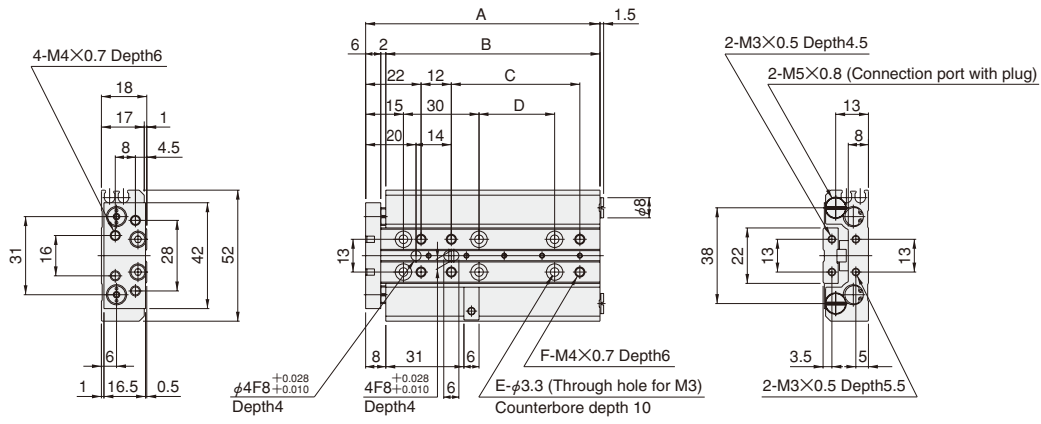

2-M5×0.8 (Connection port) Mounting groove for stroke adjusting mechanism (Not available for stroke 10.)

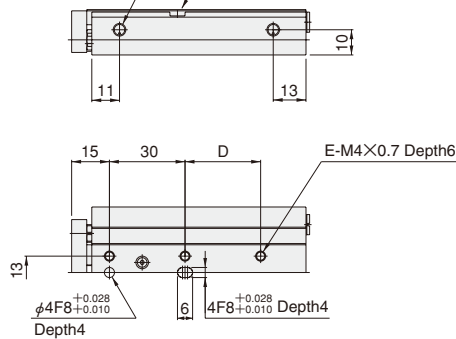

Stroke	Code	A	B	C	D	E	F
10		53	45	—	—	4	4
20		63	55	21	—	4	6
30		73	65	31	—	4	6
40		83	75	41	—	4	6
(50)		93	85	51	30	6	6
(60)		103	95	61	30	6	6
(70)		113	105	71	30	6	6

Note: Strokes in parentheses ( ) are made to order products.

## ● Symmetrical cylinder

ZSBB6 ×

Remark: The sensor mounting location, connection port, and stopper position are on the opposite side with respect to the body center line in relation to the standard cylinder shown above.

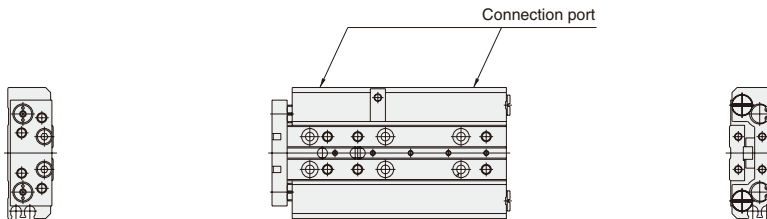

● Cylinder with buffer



ZSG6 ×

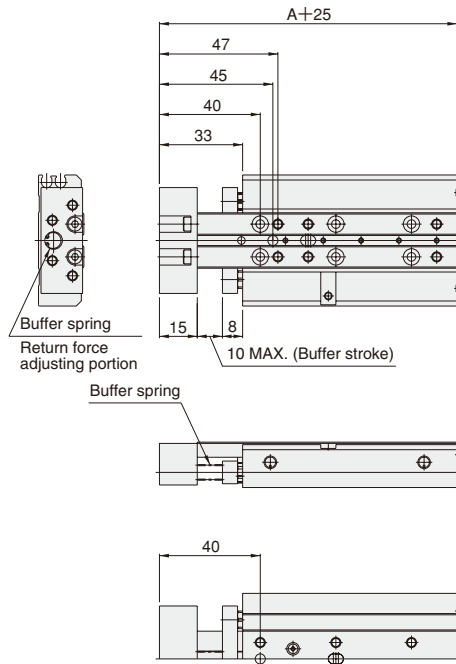

● Cylinder with rubber stopper



ZS6 ×  -RS2

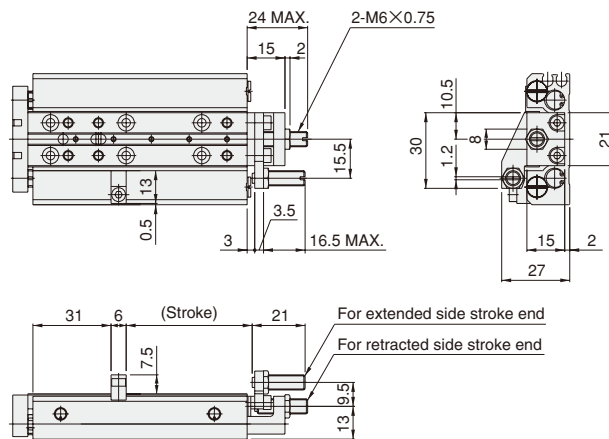

# φ 10 [0.394in.] Dimensions (mm)

## ● Standard cylinder ZS10 ×

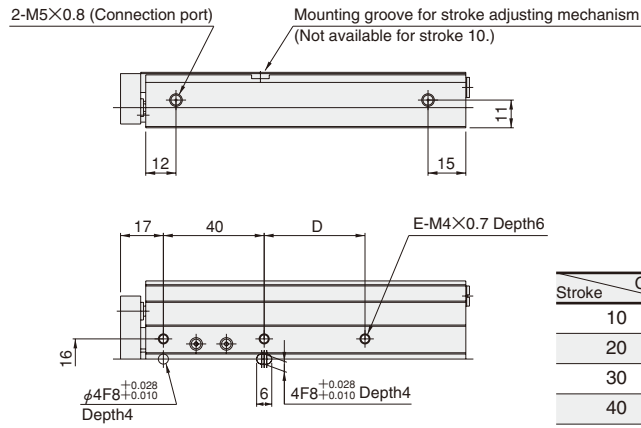
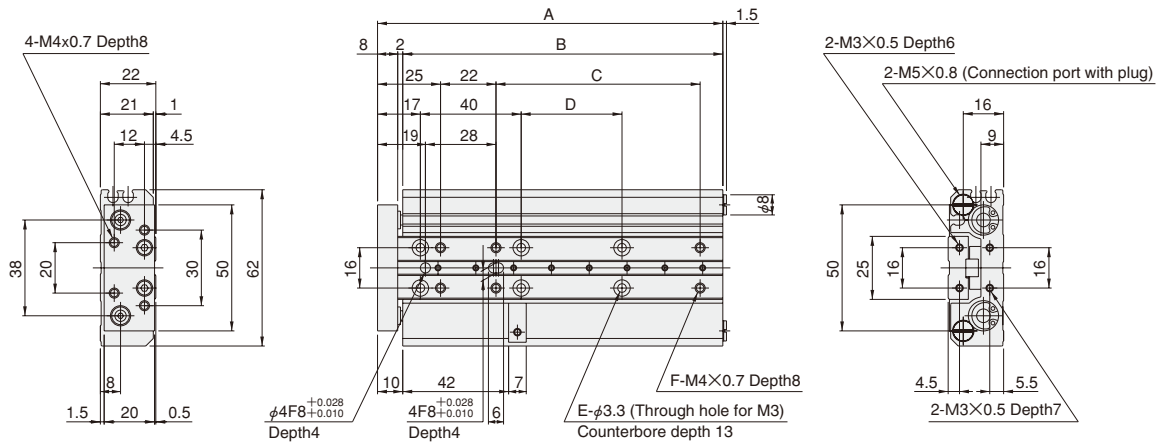

Stroke	Code	A	B	C	D	E	F
10		67	57	—	—	4	4
20		77	67	21	—	4	6
30		87	77	31	—	4	6
40		97	87	41	—	4	6
50		107	97	51	—	4	6
(60)		117	107	61	40	6	6
(70)		127	117	71	40	6	6
(80)		137	127	81	40	6	6
(90)		147	137	91	40	6	6
(100)		157	147	101	40	6	6

Note: Strokes in parentheses ( ) are made to order products.

## ● Symmetrical cylinder ZSBB10 ×

Remark: The sensor mounting location, connection port, and stopper position are on the opposite side with respect to the body center line in relation to the standard cylinder shown above.

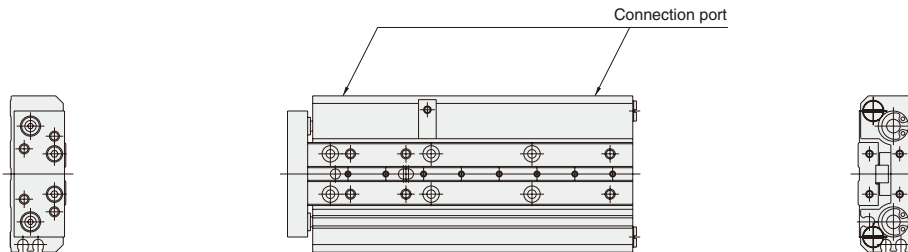

● Cylinder with buffer

ZSG10 ×

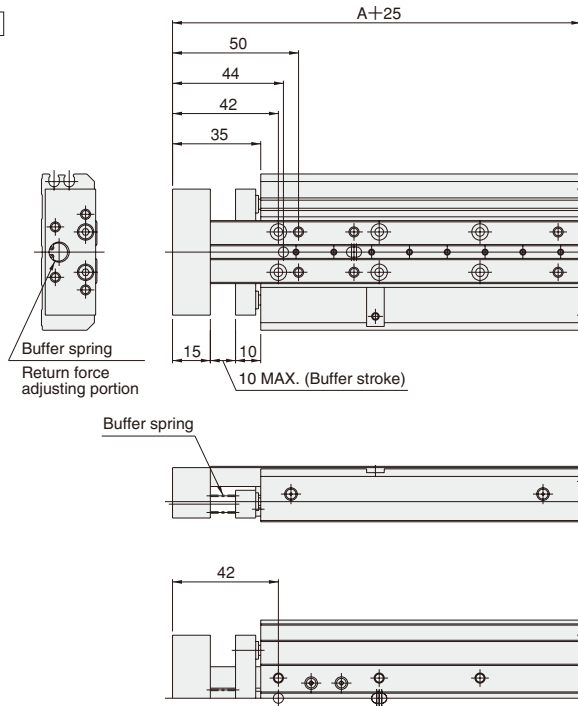

● Cylinder with rubber stopper

ZS10 ×  -RS2

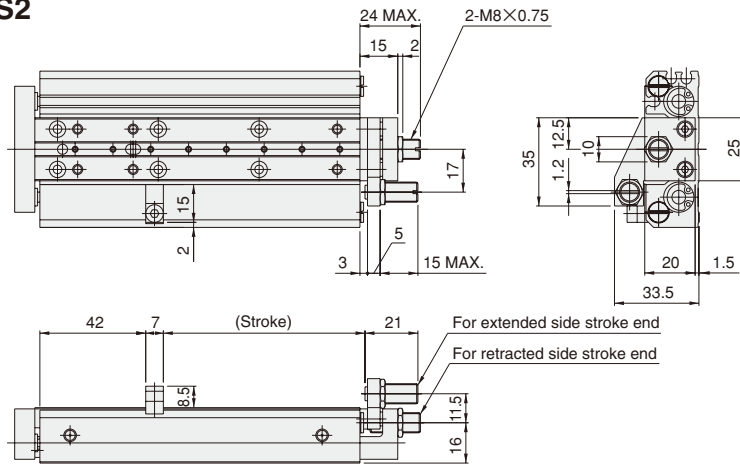
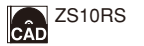

● Cylinder with shock absorber

ZS10 ×  -SS2

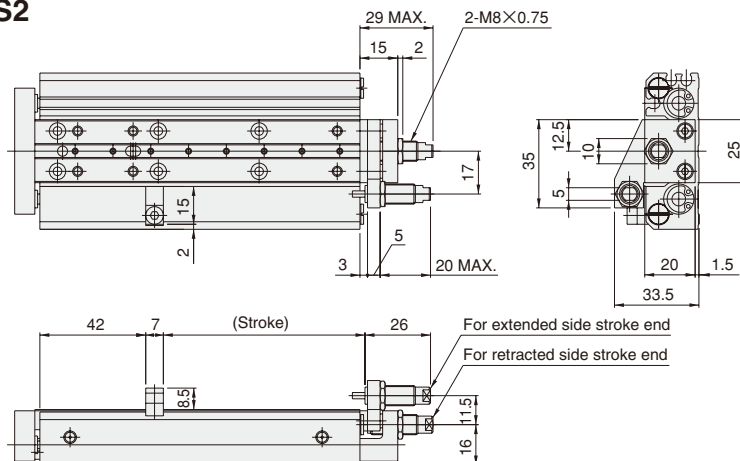
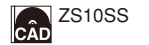

# φ 16 [0.630in.] Dimensions (mm)

## ● Standard cylinder

ZS16 ×

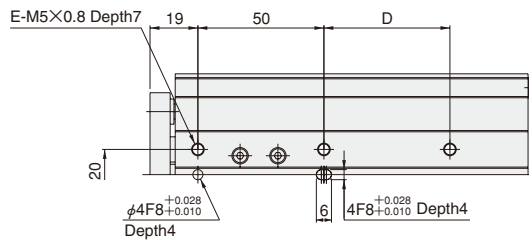
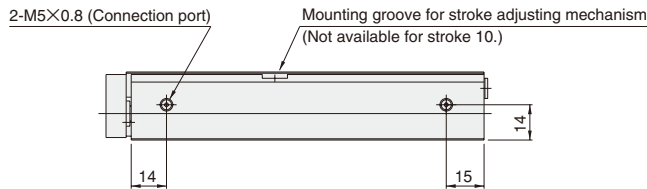
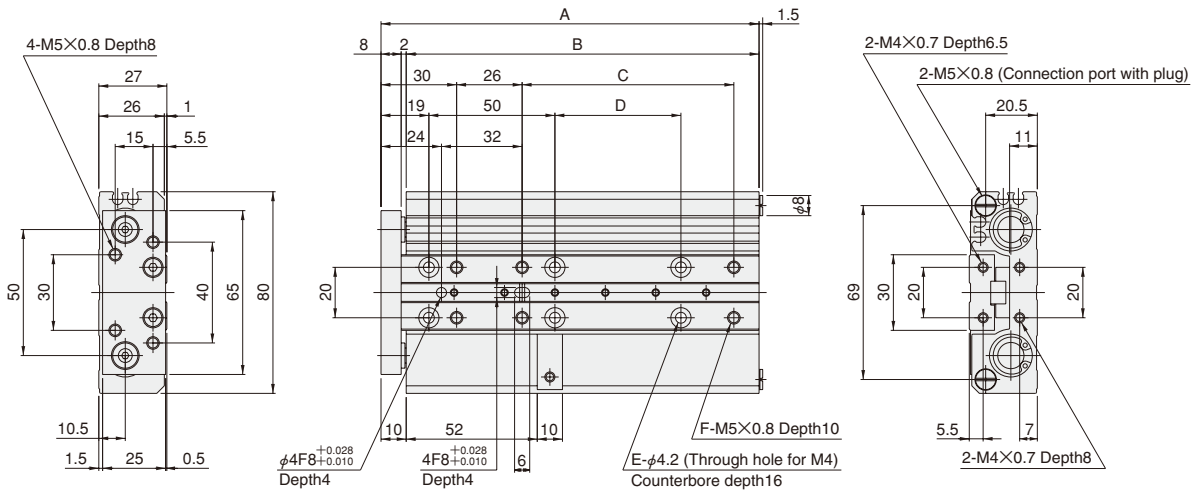

Stroke	Code	A	B	C	D	E	F
10		80	70	—	—	4	4
20		90	80	24	—	4	6
30		100	90	34	—	4	6
40		110	100	44	—	4	6
50		120	110	54	—	4	6
(60)		130	120	64	—	4	6
(70)		140	130	74	50	6	6
80		150	140	84	50	6	6
(90)		160	150	94	50	6	6
(100)		170	160	104	50	6	6

Note: Strokes in parentheses ( ) are made to order products.

## ● Symmetrical cylinder

ZSBB16 ×

Remark: The sensor mounting location, connection port, and stopper position are on the opposite side with respect to the body center line in relation to the standard cylinder shown above.

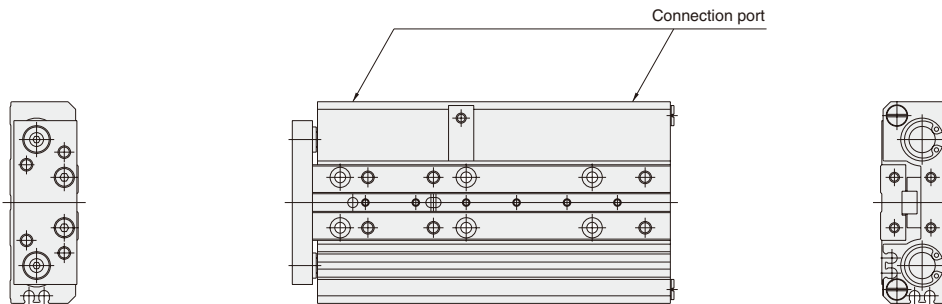

● Cylinder with buffer

ZSG16 × Stroke

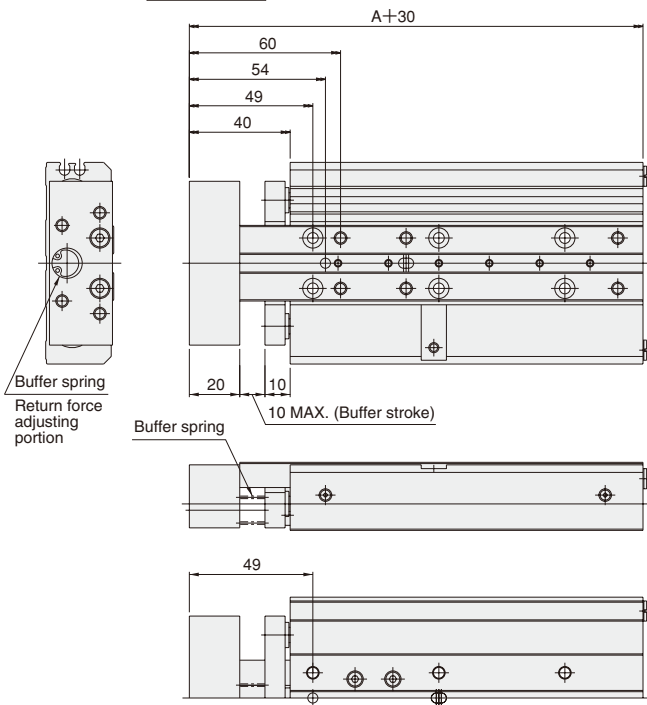

● Cylinder with end keep

ZSK16 × Stroke

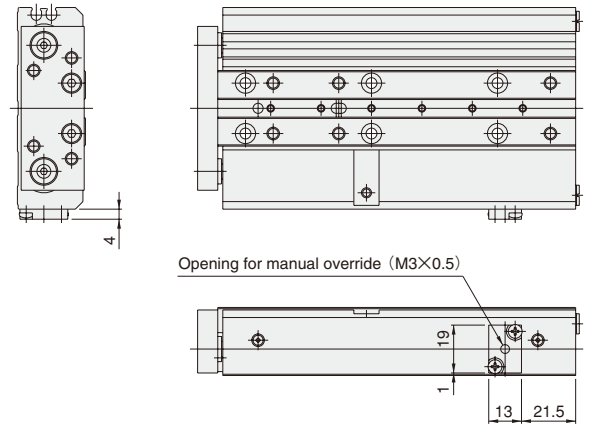

● Cylinder with rubber stopper

ZS16 × Stroke -RS2

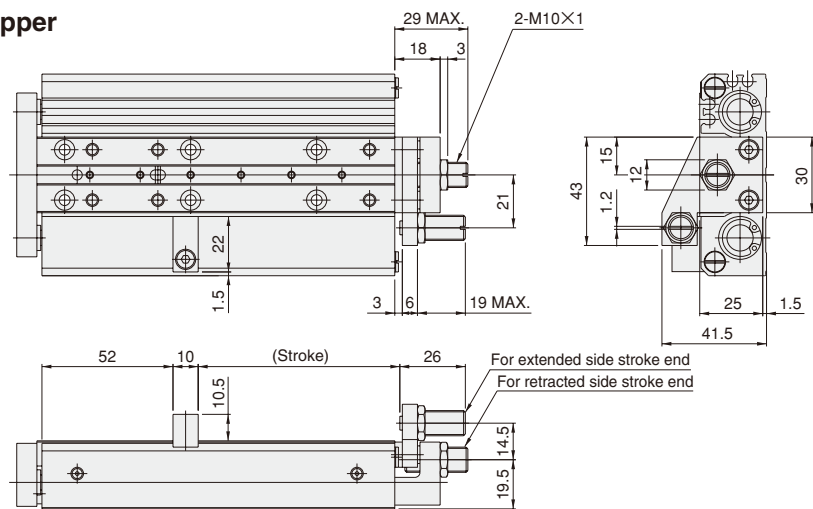

● Cylinder with shock absorber

ZS16 × Stroke -SS2

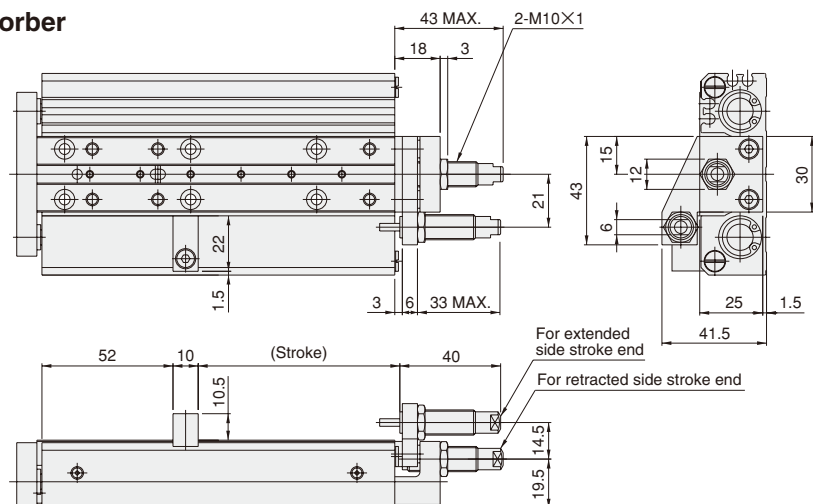

# φ 20 [0.787in.] Dimensions (mm)

## ● Standard cylinder



ZS20 × Stroke

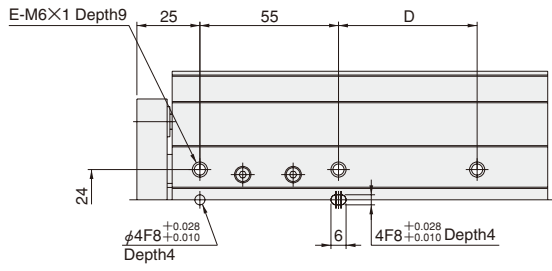
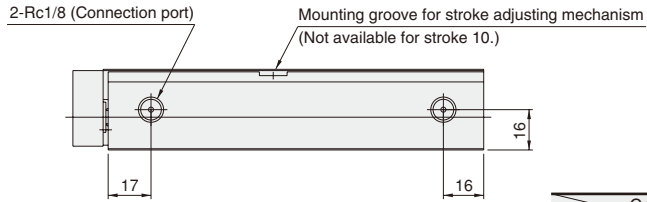
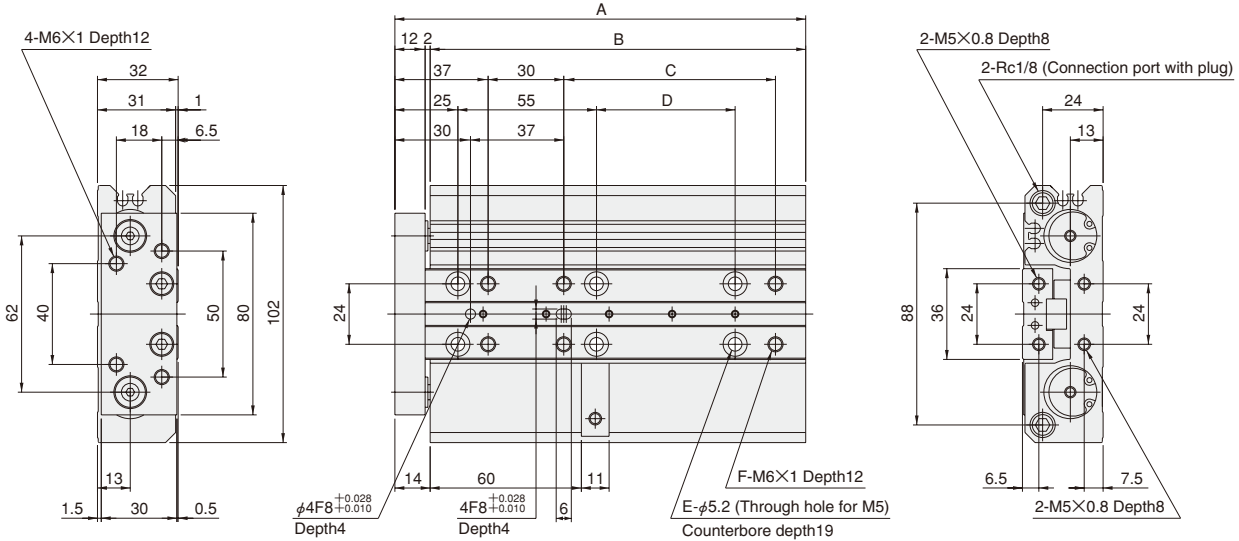

Stroke	Code	A	B	C	D	E	F
10		93	79	—	—	4	4
20		103	89	24	—	4	6
30		113	99	34	—	4	6
40		123	109	44	—	4	6
50		133	119	54	—	4	6
(60)		143	129	64	—	4	6
(70)		153	139	74	—	4	6
80		163	149	84	55	6	6
(90)		173	159	94	55	6	6
(100)		183	169	104	55	6	6

Note: Strokes in parentheses ( ) are made to order products.

## ● Symmetrical cylinder

ZSBB20 × Stroke

Remark: The sensor mounting location, connection port, and stopper position are on the opposite side with respect to the body center line in relation to the standard cylinder shown above.

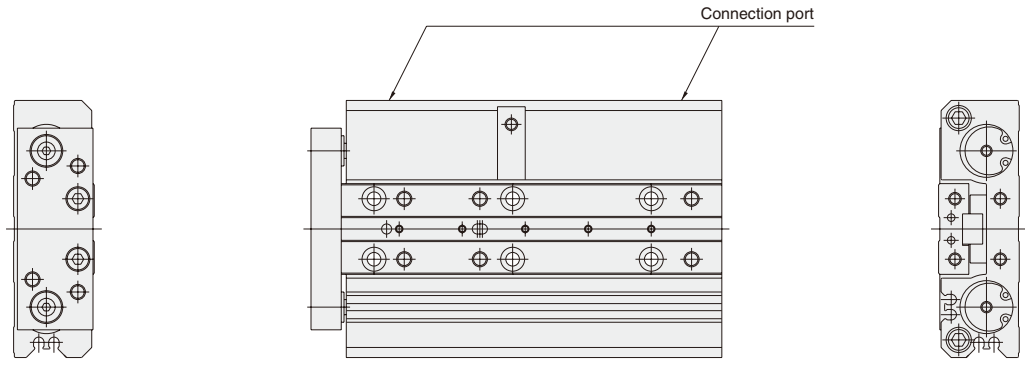

Z SLIDERS

● Cylinder with buffer

ZSG20 × Stroke



● Cylinder with end keep

ZSK20 × Stroke

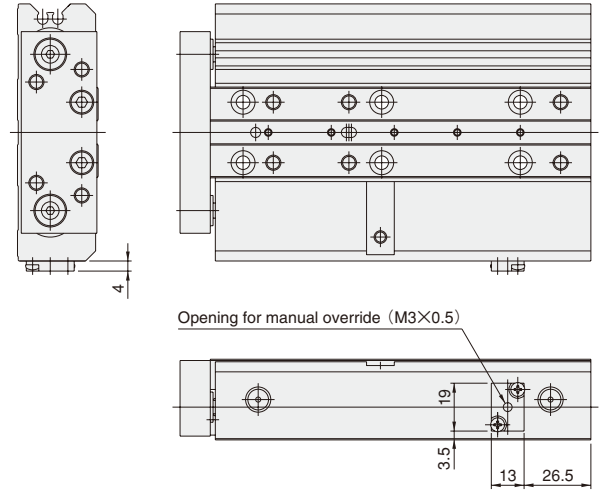
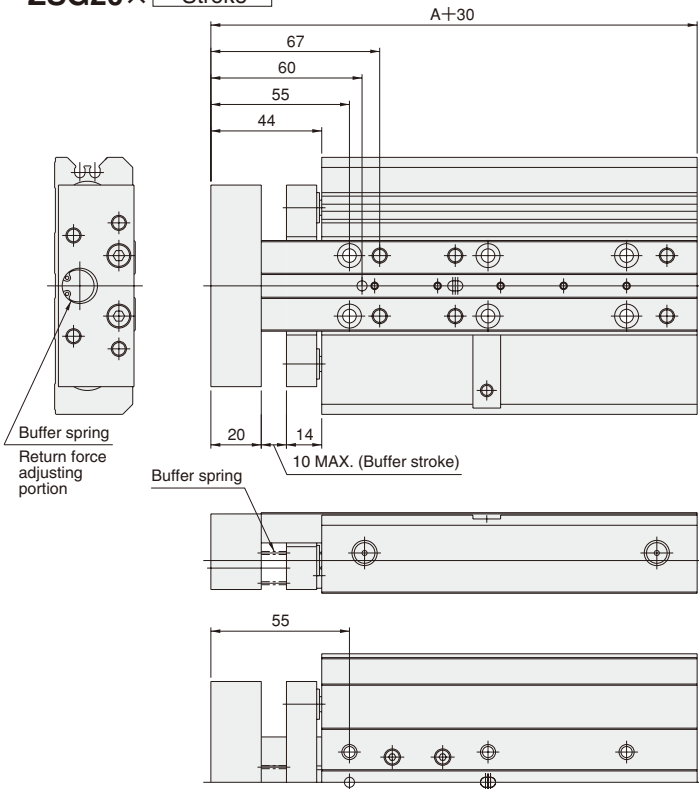

● Cylinder with rubber stopper

ZS20 × Stroke -RS2

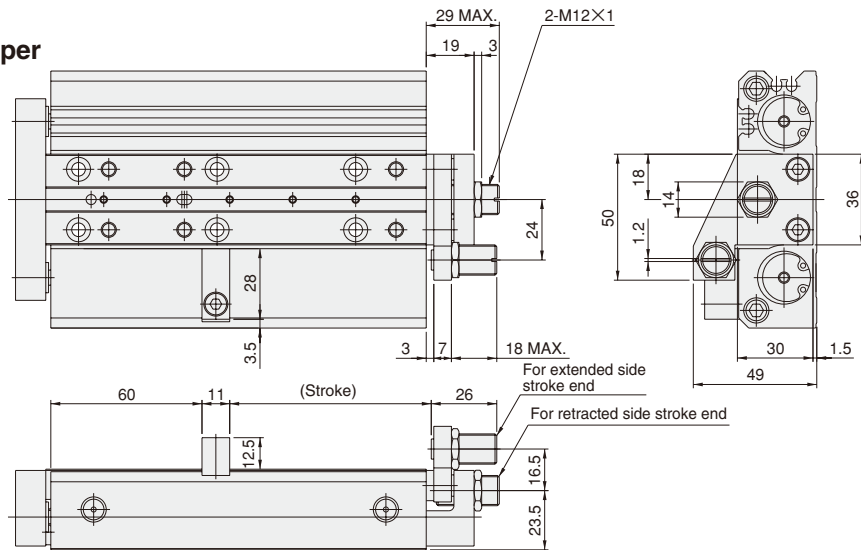

● Cylinder with shock absorber

ZS20 × Stroke -SS2

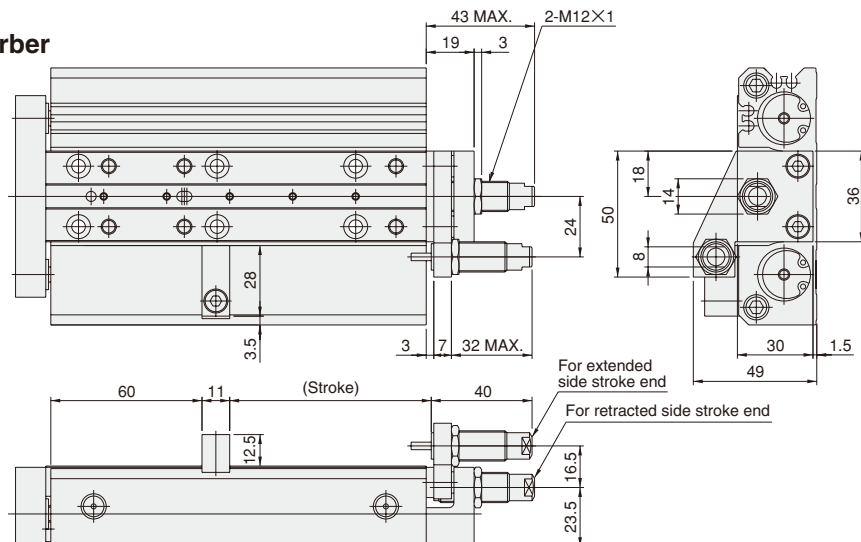



# φ 25 [0.984in.] Dimensions (mm)

## ● Standard cylinder

ZS25 ×  Stroke

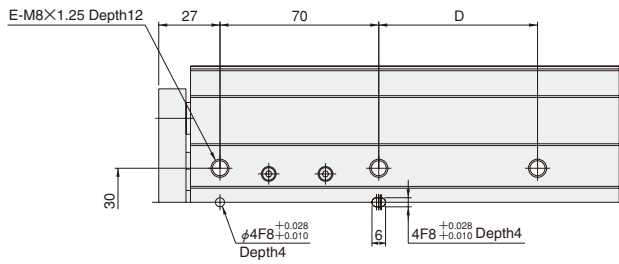
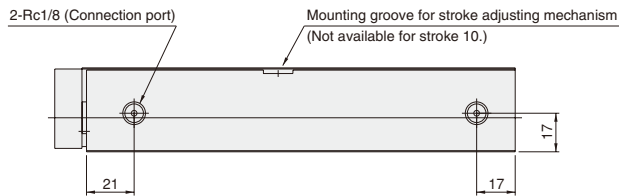
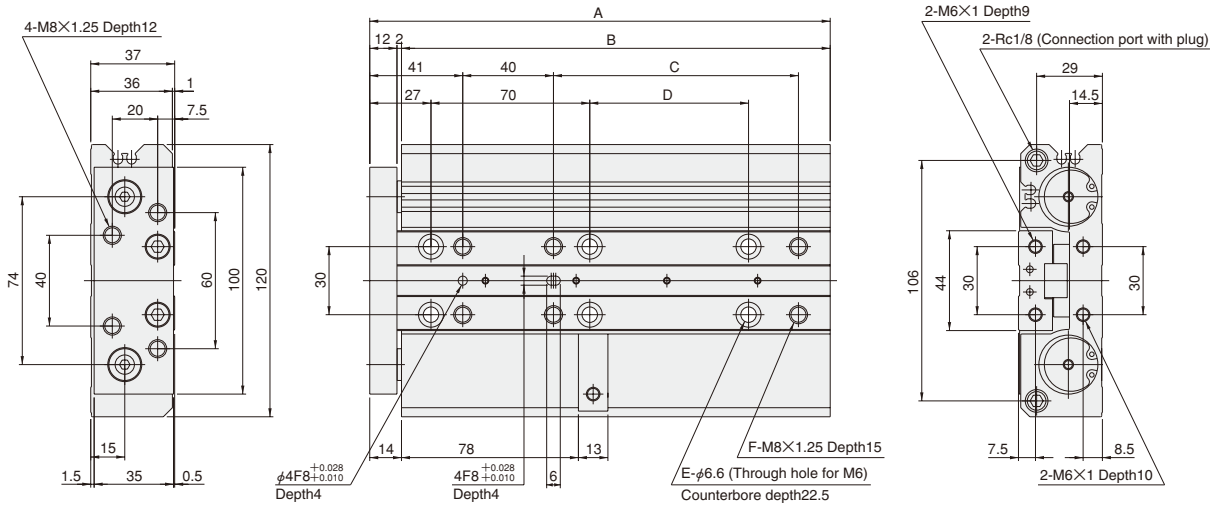

Stroke	Code	A	B	C	D	E	F
10		113	99	—	—	4	4
20		123	109	28	—	4	6
30		133	119	38	—	4	6
40		143	129	48	—	4	6
50		153	139	58	—	4	6
(60)		163	149	68	—	4	6
(70)		173	159	78	—	4	6
80		183	169	88	—	4	6
(90)		193	179	98	70	6	6
(100)		203	189	108	70	6	6

Note: Strokes in parentheses ( ) are made to order products.

## ● Symmetrical cylinder

ZSBB25 ×  Stroke

Remark: The sensor mounting location, connection port, and stopper position are on the opposite side with respect to the body center line in relation to the standard cylinder shown above.

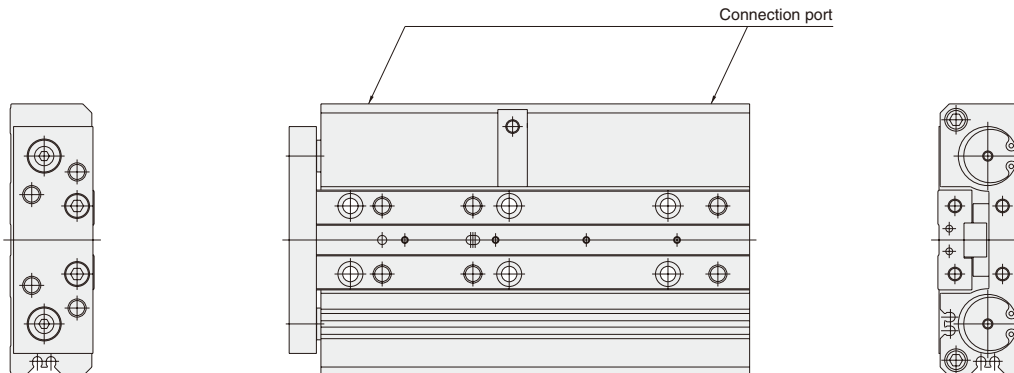

● Cylinder with buffer

ZSG25 × Stroke



● Cylinder with end keep

ZSK25 × Stroke

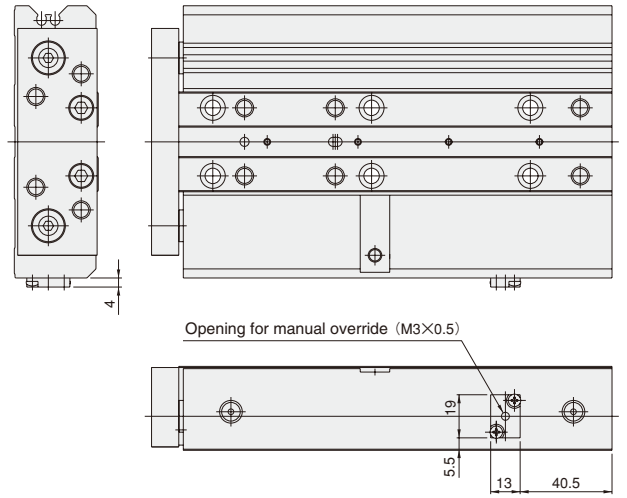
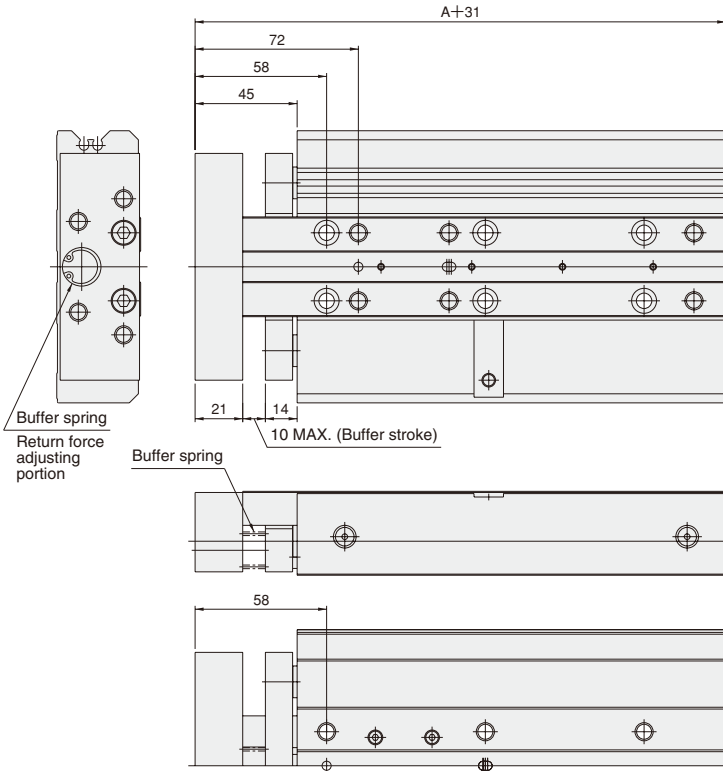

● Cylinder with rubber stopper

ZS25 × Stroke -RS2

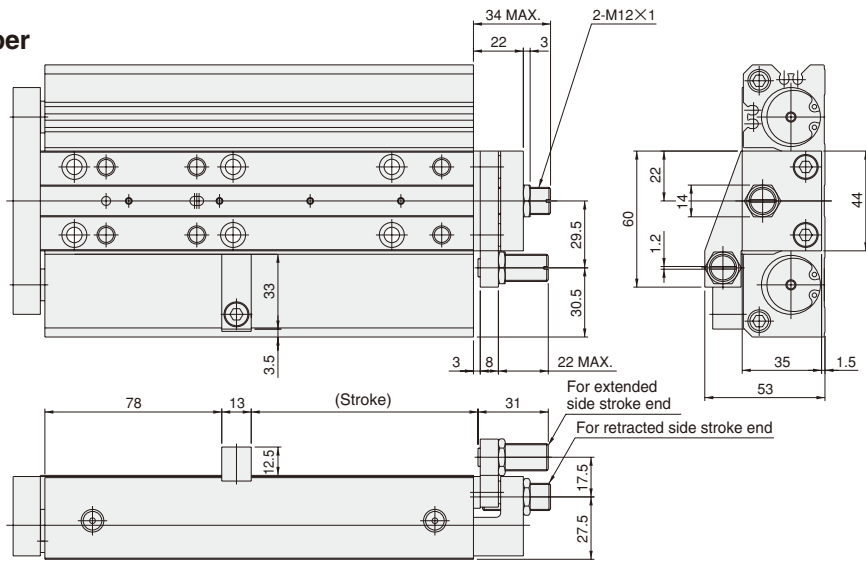

● Cylinder with shock absorber

ZS25 × Stroke -SS2

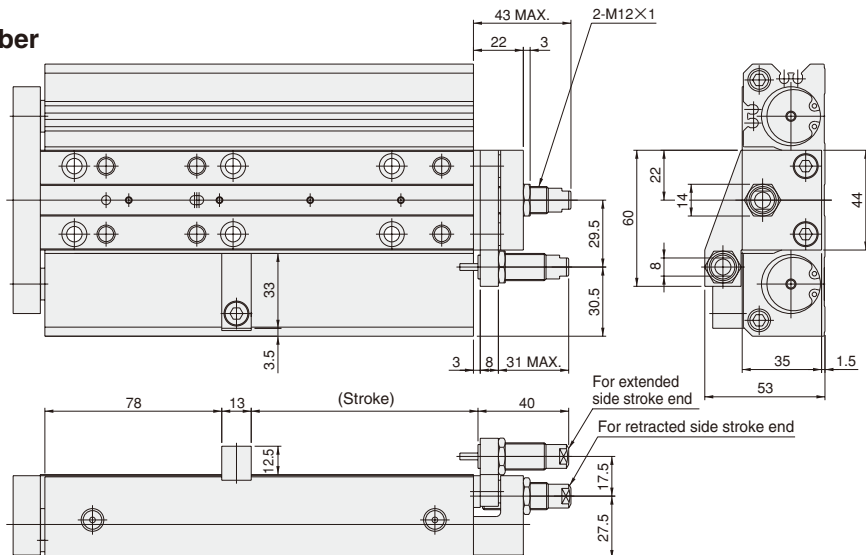

# SENSOR SWITCHES

Solid State Type, Reed Switch Type

## Symbol

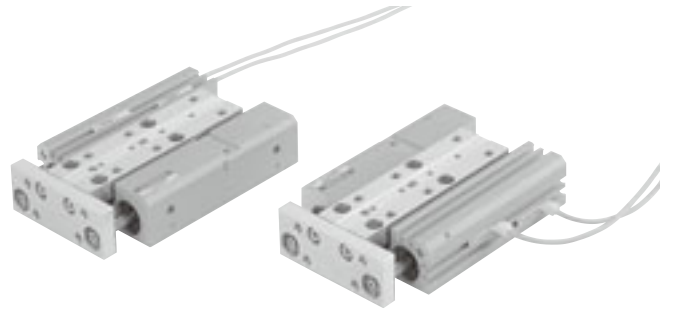
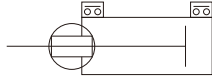

## Order Codes

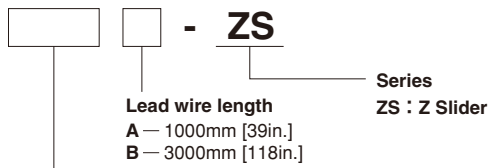

### Sensor switch

<b>ZE135</b> — 2-lead wire Solid state type with indicator lamp	Horizontal lead wire	DC10~28V
<b>ZE235</b> — 2-lead wire Solid state type with indicator lamp	Vertical lead wire	DC10~28V
<b>ZE101</b> — Reed switch type without indicator lamp	Horizontal lead wire	DC5~28V AC85~115V
<b>ZE201</b> — Reed switch type without indicator lamp	Vertical lead wire	DC5~28V AC85~115V
<b>ZE155</b> — 3-lead wire Solid state type with indicator lamp	Horizontal lead wire	DC4.5~28V
<b>ZE255</b> — 3-lead wire Solid state type with indicator lamp	Vertical lead wire	DC4.5~28V
<b>ZE102</b> — Reed switch type with indicator lamp	Horizontal lead wire	DC10~28V AC85~115V
<b>ZE202</b> — Reed switch type with indicator lamp	Vertical lead wire	DC10~28V AC85~115V

● For details of sensor switches, see p.1544.

## Minimum Cylinders Strokes when Using Sensor Switches

### ● Solid state type

Bore size mm [in.]	2 pcs. mounting		1pc. mounting	
	Top surface mounting	Side mounting	Top surface mounting	Side mounting
6 [0.236] <sup>Note 1</sup>	—	5	—	5
10 [0.394]	20 <sup>Note 2</sup>	5	5	
16~25 [0.630~0.984]	10		5	

### ● Reed switch type

Bore size mm [in.]	2 pcs. mounting		1pc. mounting	
	Top surface mounting	Side mounting	Top surface mounting	Side mounting
6 [0.236] <sup>Note 1</sup>	—	10	—	5
10 [0.394]	20 <sup>Note 2</sup>	10	5	
16~25 [0.630~0.984]	10		10	

Notes: 1. There is no sensor mounting groove on the top surface of the  $\phi 6$ .  
2. Since only 1 sensor mounting groove is on the top surface of the  $\phi 10$  size, this case assumes that 2 sensor switches have been mounted in the single groove facing lead wires outward.

## Moving Sensor Switch

- Loosening the mounting screw allows the sensor switch to be moved along the switch mounting groove of the cylinder body.
- Tighten the mounting screw with a tightening torque of 0.1~0.2N·m [0.9~1.8in·lbf]. Overtightening could damage the sensor switch and actuator.

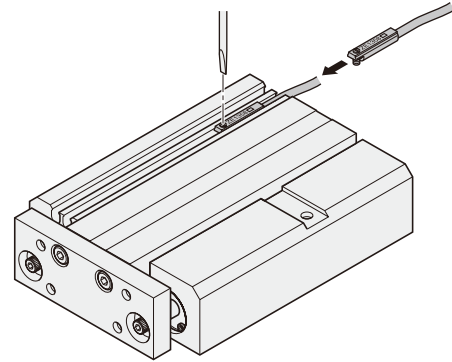

## Sensor Switch Operating Range, Response Differential, and Maximum Sensing Location

### ● Operating range: $\ell$

The distance the piston travels in one direction, while the switch is in the ON position.

### ● Response differential: C

The distance between the point where the piston turns the switch ON and the point where the switch is turned OFF as the piston travels in the opposite direction.

### ● Solid state type

Item \ Bore	6 [0.236]	10 [0.394]	16 [0.630]	20 [0.787]	25 [0.984]
Operating range: $\ell$	2.5~3.5 [0.098~0.138]	2.5~4.0 [0.098~0.157]	2.0~4.5 [0.079~0.177]		2.5~5.5 [0.098~0.217]
Response differential :C	1.0 [0.039] or less		1.2 [0.047] or less		1.5 [0.059] or less
Maximum sensing location <sup>Note</sup>	6 [0.236]				

Remark: The above table shows reference values.

Note: This is the length measured from the switch's opposite end side to the lead wire.

### ● Reed switch type

Item \ Bore	6 [0.236]	10 [0.394]	16 [0.630]	20 [0.787]	25 [0.984]
Operating range: $\ell$	4.5~7.5 [0.177~0.295]	6.5~8.5 [0.256~0.335]	6.0~8.0 [0.236~0.315]	7.0~9.5 [0.276~0.374]	
Response differential :C	1.5 [0.059] or less				
Maximum sensing location <sup>Note</sup>	10 [0.394]				

Remark: The above table shows reference values.

Note: This is the length measured from the switch's opposite end side to the lead wire.

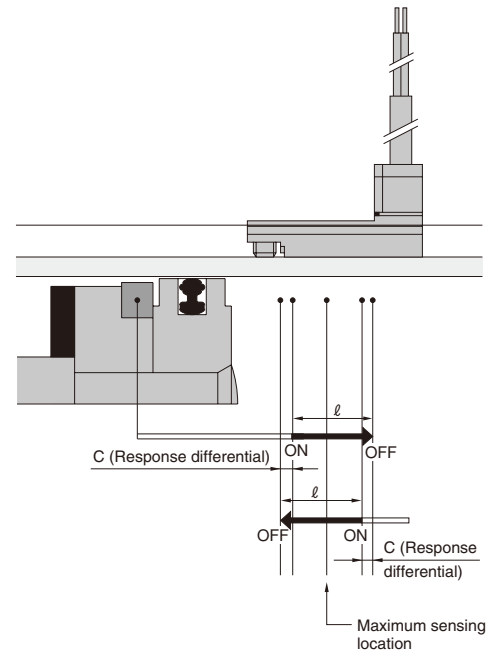

## Mounting Location of End of Stroke Detection Sensor Switch

When the sensor switch is mounted in the locations shown below, the magnet comes to the maximum sensing location of the sensor switch at the end of the stroke.

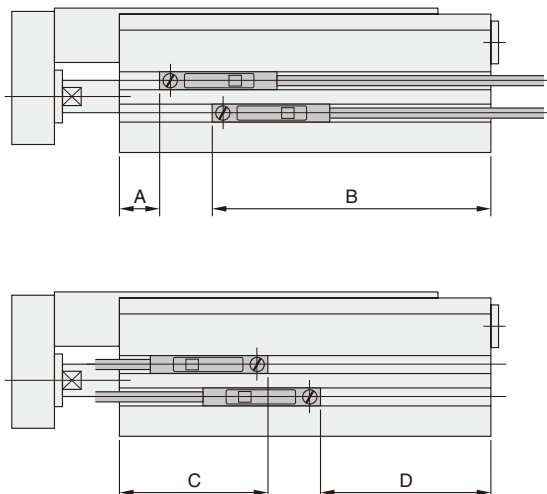

### ● Solid state type

Code \ Bore	(ZE135, ZE155, ZE235, ZE255)				
	6 [0.236]	10 [0.394]	16 [0.630]	20 [0.787]	25 [0.984]
A	6.25 [0.246]	9.25 [0.364]	11.5 [0.453]	13.6 [0.535]	17.0 [0.669]
B	28.75 [1.132]	37.75 [1.486]	48.5 [1.909]	55.4 [2.181]	72.0 [2.835]
C	18.25 [0.719]	21.25 [0.837]	23.5 [0.925]	25.6 [1.008]	29.0 [1.142]
D	16.75 [0.659]	25.75 [1.014]	36.5 [1.437]	43.4 [1.709]	60.0 [2.362]

### ● Reed switch type

Code \ Bore	(ZE101, ZE102, ZE201, ZE202)				
	6 [0.236]	10 [0.394]	16 [0.630]	20 [0.787]	25 [0.984]
A	2.25 [0.089]	5.25 [0.207]	7.5 [0.295]	9.6 [0.378]	13.0 [0.512]
B	32.75 [1.289]	41.75 [1.644]	52.5 [2.067]	59.4 [2.339]	76.0 [2.992]
C	22.25 [0.876]	25.25 [0.994]	27.5 [1.083]	29.6 [1.165]	33.0 [1.299]
D	12.75 [0.502]	21.75 [0.856]	32.5 [1.280]	39.4 [1.551]	56.0 [2.205]

A: Extended side mounting location (when lead wire is pulled out to head side)

B: Retracted side mounting location (when lead wire is pulled out to head side)

C: Extended side mounting location (when lead wire is pulled out to rod side)

D: Retracted side mounting location (when lead wire is pulled out to rod side)

Note: The sensor switch mounting location is the distance between the main body end surface and the sensor switch end surface opposite to the lead wire side.