

Pearl Rotary Joints

NC Series

FEATURES

1. Need no lubrication, low maintenance
2. Capable of high temperature and pressure
3. Long life due to low friction and less wear
4. Simple design, easy maintenance

CONSTRUCTION

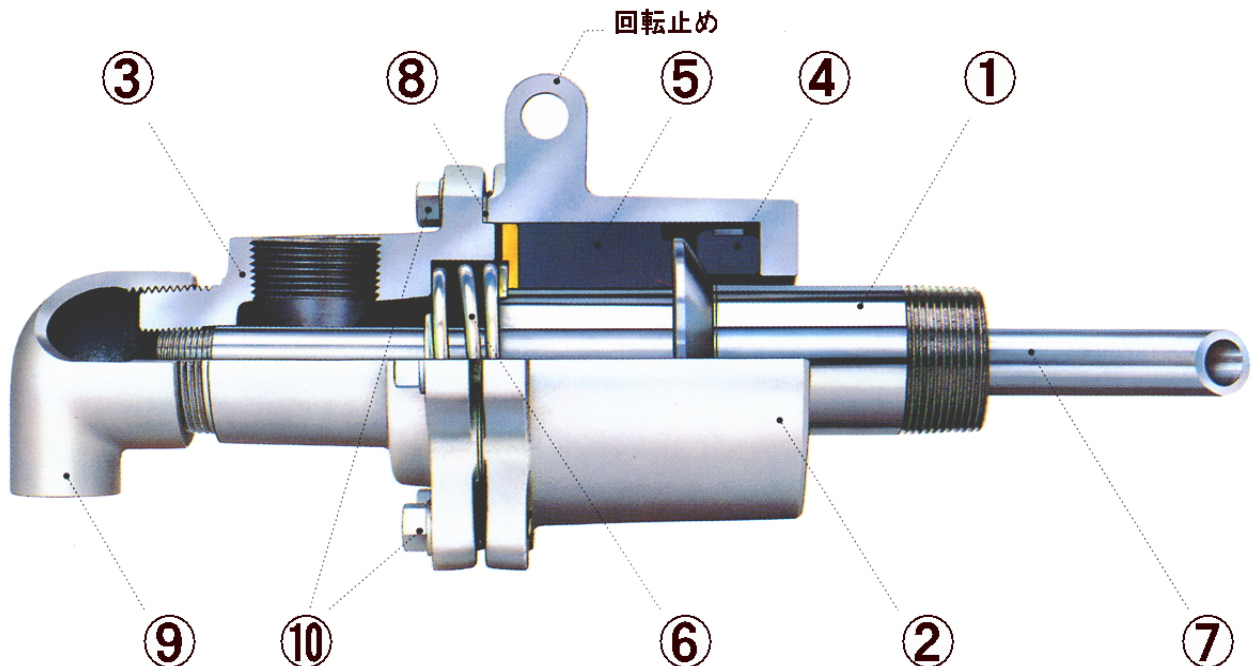

- ① ROTOR (CARBON STEEL) ② CASING (CASTING IRON) ③ HEAD (CASTING IRON) ④ SEAL RING (CARBON)
 ⑤ CARBON BEARING ⑥ SPRING (S. STEEL) ⑦ INTERNAL PIPE ⑧ GASKET ⑨ ELBOW ⑩ BOLT

SERVICE CONDITIONS

Fluid	Steam, Therm Oil
Max. Temperature	180 degrees C
Max. Pressure	1.47MPa
Max. Rotation Speed	15A to 40A 300min ⁻¹ 50A to 80A 100min ⁻¹

Electroless Nickel Plating is available for corrosive fluids upon request.

In the NCZ type, the head connecting port is directed opposite (180°) to the position shown in the brochure.

NOTE

- Operation at Max. pressure combined with Max. speed should be avoided.
 The joint should not run dry (without liquid).

DIMENSIONS

NCL Type Simplex, Thread Connection

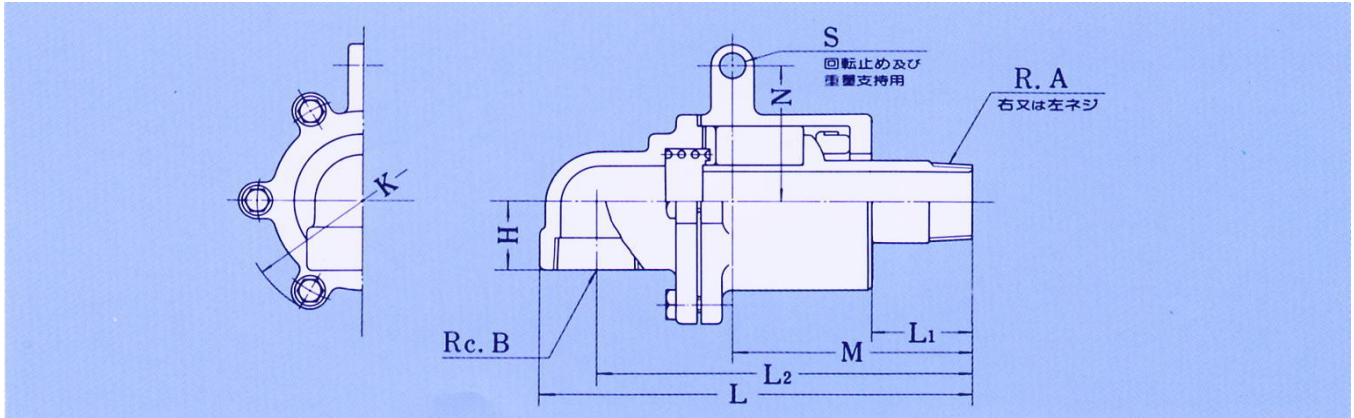

SIZE		A	B	H	K	L1	L2	L	M	N	S
(A)	(B)										
15	1/2	1/2	1/2	25	92	40	140	160	95	50	12
20	3/4	3/4	3/4	25	92	45	145	165	100	50	12
25	1	1	1	30	104	50	165	190	110	60	12
32	1 1/4	1 1/4	1 1/4	35	119	53	180	208	113	65	12
40	1 1/2	1 1/2	1 1/2	40	144	60	215	245	140	80	15
50	2	2	2	50	166	60	229	270	145	90	15
65	2 1/2	2 1/2	2 1/2	55	188	70	255	305	165	100	18
80	3	3	3	62	219	80	310	365	205	110	18

NCLF Type Simplex, Flange Connection

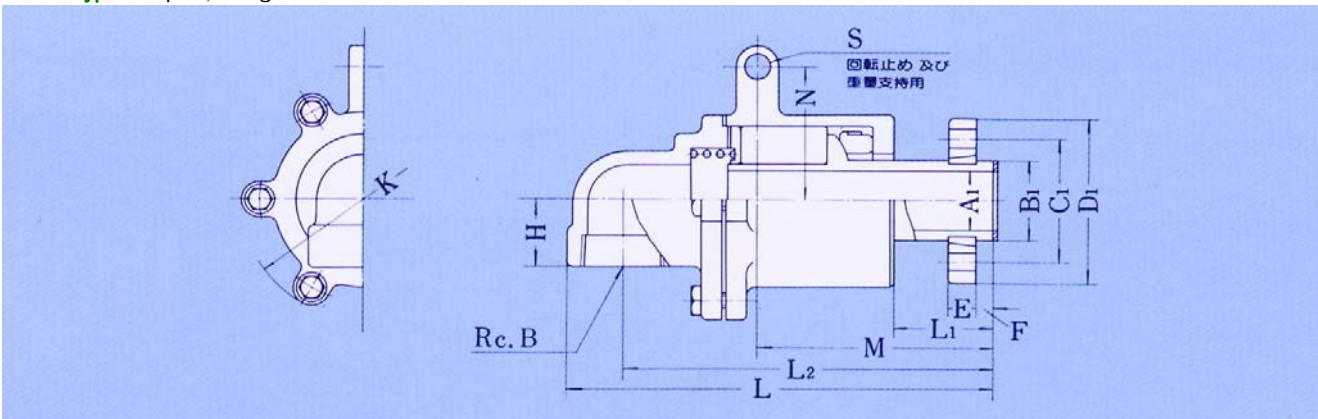

SIZE		B	H	K	L1	L2	L	M	N	S	FLANGE DIMENSIONS						
(A)	(B)										A1	B1	C1	D1	E	F	BOLTS
15	1/2	1/2	25	92	52	152	172	106	50	12	14	25	54	74	12	9	4-M10
20	3/4	3/4	25	92	45	145	165	100	50	12	17	26	54	74	12	8	4-M10
25	1	1	30	104	50	165	190	110	60	12	22	34	60	80	12	8	4-M10
32	1 1/4	1 1/4	35	119	53	180	208	113	65	12	30	42	75	96	14	10	4-M10
40	1 1/2	1 1/2	40	144	60	215	245	140	80	15	35	48	75	96	14	10	4-M10
50	2	2	50	166	60	229	270	145	90	15	48	60	95	120	14	12	4-M12
65	2 1/2	2 1/2	55	188	70	255	305	165	100	18	60	75	110	136	16	16	4-M12
80	3	3	62	219	80	310	365	205	110	18	72	90	125	154	20	22	6-M12

The flange connection type is supplied with a copper gasket (to be attached on the shaft end), along with a stud bolt, nut and washer set.

When you place an order for the flange connection type, it is not necessary to specify the direction of the thread.

Since NC series has a split ring on the flange, be sure to use a gasket at the end of the shaft.

DIMENSIONS

NC Type Duplex, Stationary Internal Pipe: Thread Connection

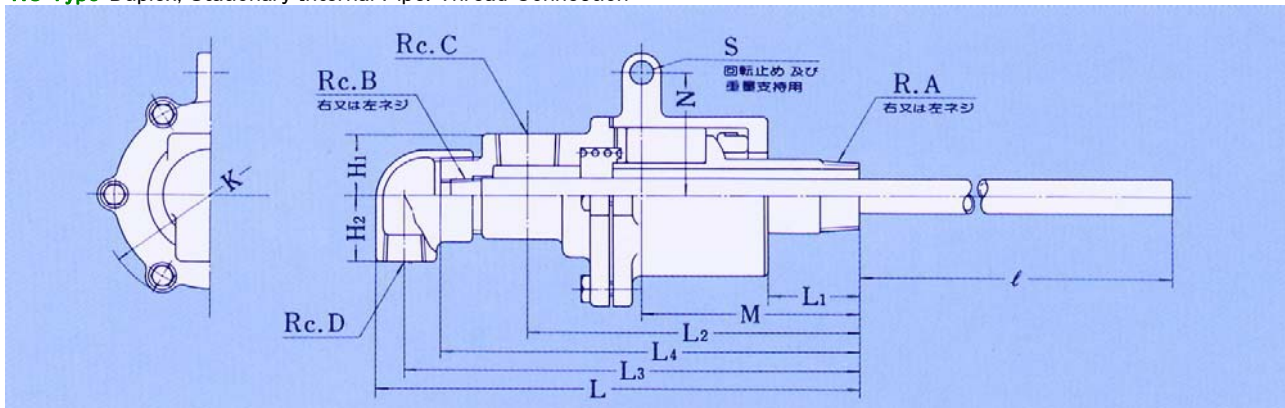

SIZE		A	B	C	D	L1	L2	L3	L4	L	H1	H2	M	N	S	K
(A)	(B)															
15	1/2	1/2	1/8	1/2	1/2	40	140	200	178	213	25	33	95	50	12	92
20	3/4	3/4	1/4	3/4	1/2	45	145	205	183	218	25	33	100	50	12	92
25	1	1	3/8	1	1/2	50	165	235	213	248	28	38	110	60	12	104
32	1 1/4	1 1/4	1/2	1	3/4	53	172	242	223	256	35	38	113	65	12	119
40	1 1/2	1 1/2	1/2, (3/4)	1 1/4	1	60	210	290	265	308	42	43	140	80	15	144
50	2	2	3/4, (1)	1 1/2	1	60	220	305	280	327	50	51	145	90	15	166
65	2 1/2	2 1/2	1, (1 1/4)	2	1 1/2	70	252	353	319	381	55	62	165	100	18	188
80	3	3	1 1/4, (1 1/2)	2 1/2	2	80	300	426	385	463	62	72	205	110	18	219

Please prepare the internal pipe by yourself. If you should place an order for the internal pipe with us, please be sure to specify the dimensions.
On types of 50A and larger, the piping connection part Rc.C is directed opposite to the rotation stopper S.

NCF Type Duplex, Stationary Internal Pipe: Flange Connection

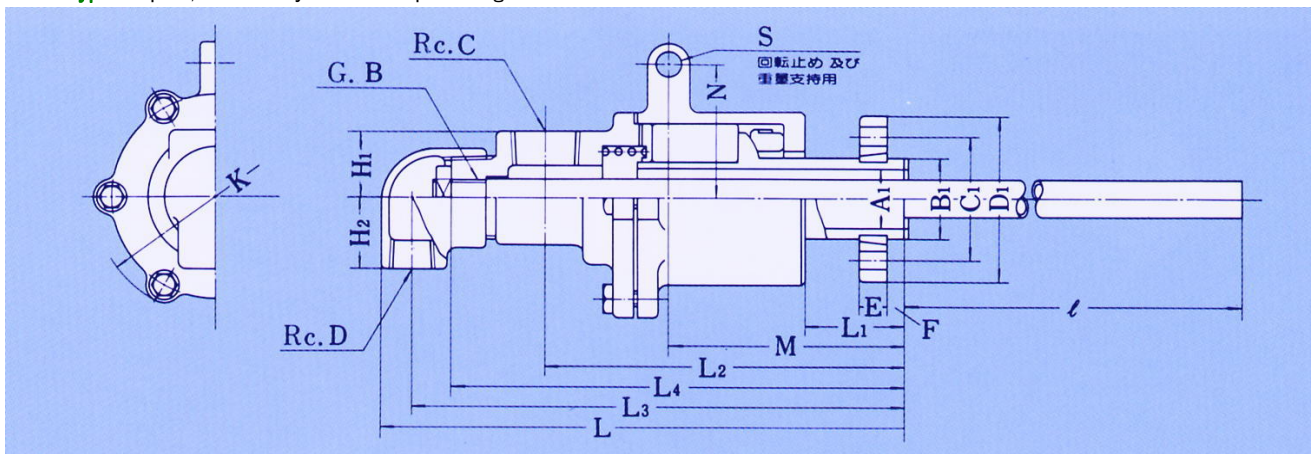

SIZE		B	C	D	L1	L2	L3	L4	L	H1	H2	M	N	S	K
(A)	(B)														
15	1/2	1/8	1/2	1/2	52	152	212	190	225	25	33	106	50	12	92
20	3/4	1/4	3/4	1/2	45	145	205	183	218	25	33	100	50	12	92
25	1	3/8	1	1/2	50	165	235	213	248	30	38	110	60	12	104
32	1 1/4	1/2	1	1/2	53	175	242	223	256	35	38	113	65	12	119
40	1 1/2	1/2, (3/4)	1 1/4	3/4	60	210	290	265	308	42	43	140	80	15	144
50	2	3/4, (1)	1 1/2	1	60	220	305	280	327	50	51	145	90	15	166
65	2 1/2	1, (1 1/4)	2	1 1/2	70	252	353	319	381	55	62	165	100	18	188
80	3	(1), 1/4, (1 1/2)	2 1/2	2	80	300	426	385	462	62	72	205	110	18	219

SIZE		FLANGE DIMENSIONS						
(A)	(B)	A1	B1	C1	D1	E	F	BOLTS
15	1/2	14	25	54	74	12	9	4-M10
20	3/4	17	26	54	74	12	8	4-M10
25	1	22	34	60	80	12	8	4-M10
32	1 1/4	30	42	75	96	14	10	4-M10
40	1 1/2	35	48	75	96	14	10	4-M10
50	2	48	60	95	120	14	12	4-M12
65	2 1/2	60	75	110	136	16	16	4-M12
80	3	72	90	125	154	20	22	6-M12

The internal pipe retaining nut is supplied with the joint. Please prepare the internal pipe by yourself. If you should place an order for the internal pipe with us, please be sure to specify the dimensions.
On types of 50A and larger, the piping connection part Rc.C is directed opposite to the rotation stopper S.
The flange connection type is supplied with a copper gasket (to be attached on the shaft end), along with a stud bolt, nut and washer set. When you place an order for the flange connection type, it is not necessary. Since NC series has a split ring on the flange, be sure to use a gasket at the end of the shaft.

NCW Type, NCFW Type Rotational Internal Pipe Type is available upon request.

FLOW RATES

Type	Nominal Size (A)	Cross Sectional Area (cm ²)	Water Flow Rate (m ³ /h)	Saturated Steam Flow Rate (when the pressure of steam is ...)				
	Out-In			(kg/h)				
				0.1(Mpa)	0.2(Mpa)	0.4(Mpa)	0.6(Mpa)	0.8(Mpa)
NC	15-6 R	0.26-0.33	0.28	3.25	4.75	7.66	10.5	13.3
	15-6 F	0.67-0.33	0.35	8.25	12.1	19.5	26.7	33.9
	20-8	0.77-0.69	0.74	9.48	13.9	22.4	30.7	39.0
	25-10	1.45-1.19	1.28	17.8	26.0	41.9	57.6	73.0
	32-15	3.37-1.94	2.09	41.3	60.3	97.4	134	170
	40-15	5.92-1.94	2.09	72.5	106	171	235	298
	40-20	3.81-3.53	3.81	46.7	68.2	110	151	192
	50-20	12.3-3.53	3.81	150	220	355	487	619
	50-25	9.02-5.73	6.18	110	161	261	358	454
	65-25	19.2-5.73	6.18	235	344	555	762	966
	65-32	14.0-9.46	10.2	171	250	403	554	703
	80-32	26.4-9.46	10.2	323	473	763	1050	1330
	80-40	22.2-12.9	14.0	271	397	641	879	1120
NCL	15 R	1.13	1.22	13.9	20.3	32.7	44.9	56.9
	15 F	1.54	1.66	18.9	27.6	44.5	61.1	77.5
	20	2.27	2.45	27.8	40.6	65.6	90.1	114
	25	3.80	4.11	46.6	68.1	110	151	191
	32	7.07	7.63	86.6	127	204	280	356
	40	9.62	10.4	118	172	278	382	484
	50	18.1	19.5	222	324	523	718	911
	65	28.3	30.5	346	506	817	1120	1420
	80	40.7	44.0	499	729	1180	1620	2050

Calculation of water flow is based on the smaller area of passage, and steam flow on the cross section of out side pipe.

Velocity of Water: 3m/sec

Velocity of Steam: 30m/sec

Air: normal state

For the dimension specifications of the internal pipes, refer to "SUS304 Pipe dimensions for internal pipes" below.

"SUS304 Pipe dimensions for internal pipes"

SIZE	Outer diameter / Thickness
6A	φ 10.5xt2.0
8A	φ 13.8xt2.2
10A	φ 17.3xt2.5
15A	φ 21.7xt3.0
20A	φ 27.2xt3.0
25A	φ 34.0xt3.5
32A	φ 42.7xt4.0
40A	φ 48.6xt4.0
50A	φ 60.5xt4.0

Table of Saturated Steam : Mpa abs (Reference Value)

°C	0	+1	+2	+3	+4	+5	+6	+7	+8	+9
100	0.10	0.10	0.11	0.11	0.12	0.12	0.13	0.13	0.13	0.14
110	0.14	0.15	0.15	0.16	0.16	0.17	0.17	0.18	0.19	0.19
120	0.20	0.20	0.21	0.22	0.23	0.23	0.24	0.25	0.25	0.26
130	0.27	0.28	0.29	0.30	0.30	0.31	0.32	0.33	0.34	0.35
140	0.36	0.37	0.38	0.39	0.40	0.42	0.43	0.44	0.45	0.46
150	0.48	0.49	0.50	0.52	0.53	0.54	0.56	0.57	0.59	0.60
160	0.62	0.63	0.65	0.67	0.68	0.70	0.72	0.74	0.75	0.77
170	0.79	0.81	0.83	0.85	0.87	0.89	0.91	0.94	0.96	0.98
180	1.00	1.03	1.05	1.07	1.10	1.12	1.15	1.17	1.20	1.23
190	1.26	1.28	1.31	1.34	1.37	1.40	1.43	1.46	1.49	1.52
200	1.55	1.59	1.62	1.65	1.69	1.72	1.76	1.80	1.83	1.87
210	1.91	1.95	1.99	2.02	2.07	2.11	2.15	2.19	2.23	2.28
220	2.32	2.36	2.41	2.46	2.50	2.55	2.60	2.65	2.70	2.75
230	2.80	2.85	2.90	2.95	3.01	3.06	3.12	3.17	3.23	3.29

Subtract 0.10 from the figures of the table to obtain the gauge pressure (Mpa).

Unless specified, the pressure is written in terms of absolute pressure for steam,

or in terms of gauge pressure for air.

WEIGHT CHART(Unit = 1kg/1 piece)

	15A	20A	25A	32A	40A	50A	65A	80A
NCL	2.1	2.1	3.1	3.7	6.5	10.3	13.0	20.5
NCLF	2.6	2.6	3.7	4.3	7.3	11.1	14.2	22.5
NC	2.2	2.2	3.4	4.0	6.8	10.8	14.2	22.0
NCF	2.7	2.7	4.0	4.6	7.6	11.6	15.2	24.0

Dimensions of the apparatus to which a SGK flange is attached (For reference)

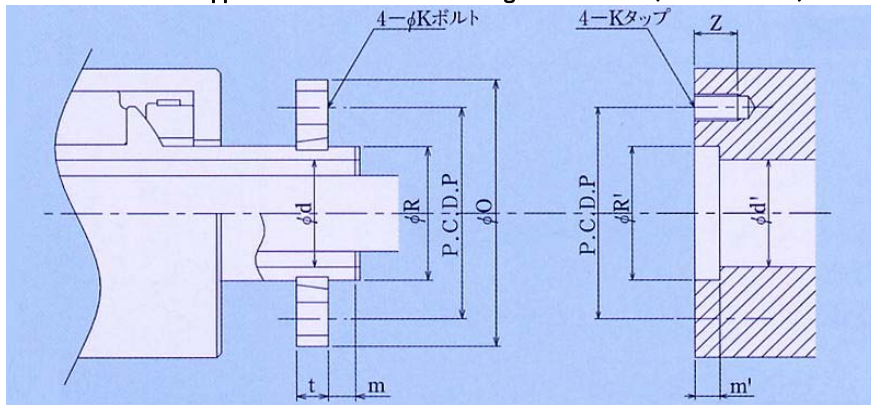

FLANGE	d	R	O	P	m	t	K
15A	14	25	74	54	9	12	M10
20A	17	26	74	54	8	12	M10
25A	22	34	80	60	8	12	M10
32A	30	42	96	75	10	14	M10
40A	35	48	96	75	10	14	M10
50A	48	60	120	95	12	14	M12
65A	60	75	136	110	16	16	M12
80A	72	90	154	125	22	20	6-M12

Dimensions of the apparatus	d'	R'	P	m'	Z
15A	14	25	54	8	16
20A	17	26	54	7	16
25A	22	34	60	7	16
32A	30	42	75	9	16
40A	35	48	75	9	16
50A	48	60	95	11	19
65A	60	75	110	13	19
80A	72	90	125	15	19

Dimension of φ R': +0.05
0

Table of NC series

	Simplex			Duplex, Stationary Internal Pipe		
	Type	Name	Our Code	Type	Name	Our Code
Thread Connection	NCL	RJ-NCL 15A LH	NC15000200	NC	RJ-NC 15A-6A LH	NC15060202
		RJ-NCL 15A RH	NC15000100		RJ-NC 15A-6A RH	NC15060101
		RJ-NCL 20A LH	NC20000200		RJ-NC 20A-8A LH	NC20080202
		RJ-NCL 20A RH	NC20000100		RJ-NC 20A-8A RH	NC20080101
		RJ-NCL 25A LH	NC25000200		RJ-NC 25A-10A LH	NC25100202
		RJ-NCL 25A RH	NC25000100		RJ-NC 25A-10A RH	NC25100101
		RJ-NCL 32A LH	NC32000200		RJ-NC 32A-15A LH	NC32150202
		RJ-NCL 32A RH	NC32000100		RJ-NC 32A-15A RH	NC32150101
		RJ-NCL 40A LH	NC40000200		RJ-NC 40A-15A LH	NC40150202
		RJ-NCL 40A RH	NC40000100		RJ-NC 40A-15A RH	NC40150101
		RJ-NCL 50A LH	NC50000200		RJ-NC 40A-20A LH	NC40200202
		RJ-NCL 50A RH	NC50000100		RJ-NC 40A-20A RH	NC40200101
		RJ-NCL 65A LH	NC65000200		RJ-NC 50A-20A LH	NC50200202
		RJ-NCL 65A RH	NC65000100		RJ-NC 50A-20A RH	NC50200101
		RJ-NCL 80A LH	NC80000200		RJ-NC 50A-25A LH	NC50250202
		RJ-NCL 80A RH	NC80000100		RJ-NC 50A-25A RH	NC50250101
		Flange Connection	NCLF		RJ-NCLF 15A	NC15001000
RJ-NCLF 20A	NC20001000			RJ-NCF 20A-8A	NC20081011	
RJ-NCLF 25A	NC25001000			RJ-NCF 25A-10A	NC25101011	
RJ-NCLF 32A	NC32001000			RJ-NCF 32A-15A	NC32151011	
RJ-NCLF 40A	NC40001000			RJ-NCF 40A-15A	NC40151011	
RJ-NCLF 50A	NC50001000			RJ-NCF 40A-20A	NC40201011	
RJ-NCLF 65A	NC65001000			RJ-NCF 50A-20A	NC50201011	
RJ-NCLF 80A	NC80001000			RJ-NCF 50A-25A	NC50251011	
				RJ-NCF 65A-25A	NC65251011	
				RJ-NCF 65A-32A	NC65321011	
				RJ-NCF 80A-32A	NC80321011	
				RJ-NCF 80A-40A	NC80401011	

Table of NC series

	Duplex, Rotatory Internal Pipe					
	Rotor Without Key Seat			Rotor With Key Seat		
	Type	Name	Our Code	Type	Name	Our Code
Thread Connection	NCW			ask		
Flange Connection	NCFW			ask		

In the NCZ type, the head connecting port is directed opposite (180°) to the position shown in the brochure.

	Simplex			Duplex, Stationary Internal Pipe		
	Type	Name	Our Code	Type	Name	Our Code
Thread Connection	NCLZ		NZ*****	NCZ		NZ*****
Flange Connection	NCLFZ		NZ*****	NCFZ		NZ*****

Precautions for Use

1. Use caution not to allow foreign matter to enter the sealed area.
 2. When installing a joint that has a fluid leakage inspection hole, be sure to direct the inspection hole downward.
 3. For joints having a fluid leakage inspection hole: When fluid leaks from the inspection hole, it is time to replace the joint.
 4. For screw-in connection types: The screw must be allowed to tighten freely against the direction of rotation.
The left-hand screw is used when the roll or drum rotates clockwise (when viewed from the rotary joint installation position); the right-hand screw is used when the roll or drum rotates counterclockwise.
 5. Avoid installing piping that would cause the rotary joint to bear the weight of the valve, etc.
 6. Use a flexible tube for connecting the rotary joint and piping.
Do not bind the joint by connecting it directly to the steel pipe.
 7. Do not give the rotation stopper on the rotary joint any excessive restraint for stopping the rotation of the joint.
 8. Lubrication is required where ball bearings are used for high-temperature operation.
Supply grease at regular intervals (the interval differs depending on the operation frequency).
 9. Do not operate the rotary joint at the maximum rotation speed under the maximum allowable working pressure.
 10. When supplying grease, remove the plug, and then top off grease.
 11. Do not leave the rotary joint at rest for long periods of time. This may cause fluid leaks due to the formation of rust.
 12. In the event of any failure, repair or replace the rotary joint promptly.
-  Continued operation with fluid leakage may cause major accident.

Causes of Failure

A sign of failure often appears as a premature fluid leakage from the sealing part. This can be found by checking whether any fluid is leaking from the inspection hole in the main body or through the gap between the rotor and casing. In many cases, the failed joint can be re-used by repairing or replacing certain parts. Please take appropriate measures before the internal parts are damaged.

Main causes of failure are as follows:

- 1) Natural wear and abnormal wear on sealing surface or bearing area
- 2) Undue restraint of joint body
 - The rotation stopper is restrained.
- 3) The center of the machine is improperly aligned with the center of the rotary joint.
 - The end face of the axis of rotation of the machine is not at a right angle to the shaft.
 - The mating part (spigot) is improperly assembled.
 - The center of the mounting screw of the machine to be connected to is incorrectly aligned.
 - The screw direction is incorrect.
 - In the case of flange connection, bolts are not evenly tightened.

(After installation, be sure to operate it at low speed and make sure that centering is achieved).
- 4) The piping ahead of the joint is improperly installed.
 - The joint is connected to a steel pipe.
 - The flexible tube does not have adequate flexibility.
 - The bending direction of the flexible tube is inappropriate.
 - The joint is directly subjected to the weight of a valve, trap or other part.
- 5) The internal pipe is not appropriate.
 - The internal pipe and siphon pipe are too heavy and held just by the screw at the joint head.
 - The internal pipe is off-center.
- 6) Use of improper product type.
 - The diameter is too small.
 - The working temperature is too high.
 - The working pressure is too high.
 - The number of RPMs is too high.
 - Operated with an improper type of fluid.
 - Operated with no fluid running.
- 7) Problem with flowing fluid
 - Foreign matter remains in the flow path such as piping, roll, etc.
 - Improper solvent medium is deposited in fluid.
 - The design of the piping installation is not appropriate.
- 8) Others --- If a failure is detected, DO NOT disassemble the joint yourself. Contact us for repairs.

Frequently Asked Questions

Q: What is the difference between "RH/LH" (representing the screw direction of the rotor of the screw-in type rotary joint) and "R/L" (stamped on the rotary joint)?

A: There is no particular difference between "RH/LH" and "R/L". "RH" and "LH" are the abbreviation of "Right Hand" and "Left Hand", respectively. "R/L" is simply used instead of "RH/LH" on the faceplate of the product.

Q: What is the difference between AC Series and NC Series?

A: They are both high-temperature types but with different structure. The AC Series is a lubricating type using a ball bearing, while the NC Series is a non-lubricating type using a carbon bearing in a spherical sealing structure.

Q: What should I do to let a screw tighten freely against the direction of rotation?

A: When installing the joint, use a screw whose direction is opposite to the direction of rotation of a rotating body to which the joint is connected.

Q: Fluid is leaking from the inspection hole.

A: It is time to repair or replace the joint.

Q: Is it possible to use RXH type to run steam as fluid?

A: The standard products of RXH type cannot be used to run steam as a fluid. For this purpose, use AC Series or NC Series.

Q: A leakage occurred shortly after installation.

A: Check installation and use conditions. Impurities in the fluid and improper installation are two common causes of many leakage failures. Use of an improper product type may also cause leakage.

When this is a new order to us

Please specify the following information in your order.

○ If you are currently using our joint

A: In the case of a joint listed in this brochure

Model, size (and, in the case of duplex type, internal pipe size), and screw direction (when using a screw-in type)

B: In the case of a special product

Model, size, screw direction (when using a screw-in type)

Serial number, date of manufacture

Model names contain "OC", "ONC", "OKC", "RXS", etc.

For flange connection types, it is not necessary to specify the screw direction.

For screw-in types, please specify the screw direction.

Please select a left-hand screw when the roll or drum rotates clockwise (when viewed from the rotary joint installation position) and a right-hand screw when the roll or drum rotates counterclockwise.

○ When this is a new order to us

1. Fluid for use, pressure, temperature, number of revolutions and description of the machine to be connected
2. Direction of rotation of the machine to be connected (Direction of rotation when viewed from the joint installation position)
3. Connection type: Screw-in connection (screw direction) or flange connection
4. Connection piping port: Screw-in connection or flange connection
5. Size
6. Structure: Simplex type or duplex type (with stationary internal pipe or rotational internal pipe)
7. Frequency of operation and working shifts
8. Working environment (e.g., use in clean room)
9. Other special requests

SHOWA GIKEN INDUSTRIAL CO., LTD.

URL <http://www.sgk-p.co.jp/>



The contents of this catalog subject to change without notice.

Tokyo Office (Export Dept.)

2-64-11, Akabane, Kita-ku, Tokyo,

115-0045 Japan

Phone.: +81-3-3598-1400

Fax.: +81-3-3598-2700

E-mail sgk-tk@sgk-p.co.jp

Osaka Office

2-9-7, Toyosaki, Kita-ku, Osaka,

531-0072 Japan

Phone.: +81-6-6371-8341

Fax.: +81-6-6371-6283

E-mail sgk-os@sgk-p.co.jp

Nagoya Office

1-107, Takaharidai, Meito-ku, Nagoya,

465-0054 Japan

Phone.: +81-52-701-4068

Fax.: +81-52-704-4051

E-mail sgk-ng@sgk-p.co.jp

Head Office

1247, Kobari-Shinsyuku, Ina-Machi, Saitama,

362-0808 Japan

Phone.: +81-48-728-8321

Fax.: +81-48-728-8360

E-mail sgk-spa@sgk-p.co.jp (Engineering Dept.)

E-mail sgk-tpa@sgk-p.co.jp (Administrative Division)