

INSTRUCTION MANUAL OF MC22 CONVUM

Read the instruction manual without fail before using the CONVUM and keep the manual with care.

WARNING

- ① Install a mechanical preventive for safety against unexpected drops of sucked work pieces, if dangerous.
- ② Avoid use of the CONVUM in locations where corrosive or inflammable gases exists. No suction of such gases by all means.

CAUTION

■ Caution of piping

- ① In case more than two pads are used with one CONVUM:
 - Leakage even by one pad lowers the vacuum condition, which causes suction error.
 - For vacuum piping, use a pipe for between CONVUM and a branch unit with a larger diameter than that for between a branch unit and pads.
- ② Use a pipe with larger diameter than specified. In case too small diameter pipes are used for vacuum piping, the vacuum degree inside CONVUM could increase, which resulting in keeping the vacuum sensor hold ON.
- ③ For coupling of the vacuum side of convum, use a fitting with side by side 12mm or less(or outer diameter 13mm or less) for jointing section.
- ④ The inner diameter of piping of the compressed air supply port to manifold type should be 6mm or more.

■ Caution of operation

- ① Operating temperature range for CONVUM is 5 °C to 50 °C, no use out of the range. (may cause troubles under frozen).
- ② Compressed air contains a lot of impurities (water, oxidized oil, tar, and foreign particles). This may cause deterioration of the functions of the CONVUM. Improve the air quality by dehumidifying with after-coolers or dryers and also remove tar with tar removing filters. Do not use lubricators.
- ③ Rust in piping may cause the malfunction. Install a compressed air filter specified for 5 micro or less filtration close to the supply port of compressed air of CONVUM.
- ④ Operate a solenoid valve within a 10% fluctuation of a rating voltage.
- ⑤ Avoid use of CONVUM under vibration of 30 m/sec-square or over, impact force 150 m/sec-square or over.
- ⑥ Install CONVUM as apart as possible from high-pressure equipment, high-voltage cables or power cables that may emit noises.
- ⑦ Water droplets spattered directly on the solenoid valve may cause short circuits or coil burnouts. Protect CONVUM with a cover or by installing inside a panel.
- ⑧ Moisture, oil, salinity, metal chips etc. may cause deteriorations in functions. Avoid suction of those materials.

■ Caution of maintenance

- ① Switch off power without fail when disassembling or changing components.
- ② Assembling or disassembling should be done by trained personnel.
- ③ Do not lose components when assembling or disassembling.
- ④ When disassembling, take a goggle for protection. Spring parts may jump out of the equipment.
- ⑤ When the length of a vacuum piping is 1.5m or more, take time more vacuum generating and vacuum breaking respectively.
- ⑥ Avoid the operation of the vacuum break control solenoid valve under the vacuum generation.
- ⑦ Supply air pressure on manifold: 0.53~0.55MPa
- ⑧ Standard clamping torques of installing each screw are M1.7: 0.05N·m/ M2: 0.07N·m/ M2.5: 0.16N·m
- ⑨ It is essential that filter elements be periodically cleaned or exchanged if necessary, because of logging of impurities which may cause inferior vacuum degree.

■ As for vacuum sensors(MVS/MPS series), refer to the instruction manual as per separate sheets. _____

■ Accessories

MODEL	Accessories	Remarks	Q' TY
MC22 single	Screws	M3×25 with plain washer	2
	Socket(lead wire:300mm long)		2

■ Caution

Fix the metal parts tightly with a spanner or something in case the fitting of coupling for the air supply port.

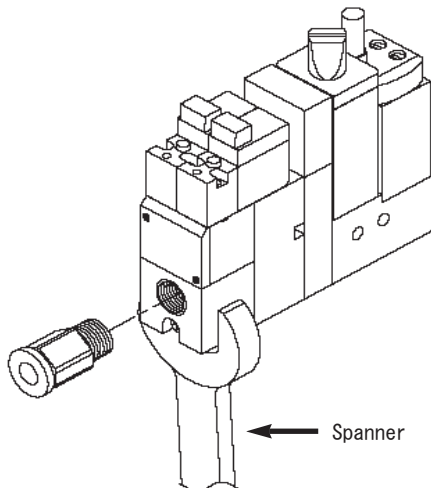

Operation (⊙function, ○caution)

Supply side piping

- Inside diameter of hose at air-supply side ... $\phi 4$ mm or over
(If the length of hose being used exceeds 2m, use hose with larger inside diameter.)
(Use a hose with inside diameter over $\phi 6$ mm when using manifold type. Use one size larger when the pipe length exceeds 2m.)
- Smaller inner diameter of hose and joints than specified may reduce the pressure, flow and vacuum performance.

Filter regulator

- Be sure to keep the specified pressure and air-flow rate stable.
- The operating pressure (0.5MPa) is specified at the air supply port during vacuum by CONVUM generating. Adjust the operating pressure by taking pressure drop into account.
- Filter should be drained periodically (Be sure to drain frequently especially when air humidity is high.)
- Never use a lubricator.

Connection to other pneumatic equipments

- Be sure to keep air actuator and CONVUM as close to the air-supply (compressor) as possible. (Otherwise it may cause insufficient supply pressure and flow volume, by which the vacuum performance may not be acquired well.)

Compressor

- Capacity of compressor should be good enough to cover the whole quantity of consumption of all pneumatic devices including CONVUM.

Silencer

- ⊙ To decrease the noise of exhausted air from CONVUM.

Vacuum-breaking control solenoid valve

- ⊙ This solenoid valve is for quick and no error release of work-piece. (Generate air for vacuum breaking when power supply is on.)
- Prevent dust, oil, etc. from entering inside. The contaminated valve by the dust may cause malfunction.

Vacuum-breaking air flow-adjusting screw

- ⊙ Vacuum-breaking air decreases when turned clockwise and increases when turned counterclockwise.

Vacuum-generating solenoid valve

- ⊙ This solenoid valve controls vacuum generation.
- Normal close: Vacuum generating under AC power supply on. Vacuum generation is stopped when AC supply off.
- Small-type 3 ports solenoid valve inside is sensitive to the dust. Be careful to the dust which may cause malfunction.

Pressure sensor

- ⊙ Sensor-on when vacuum reaches to the setting valve.
- Pressure sensor for negative pressure can be installed. (Be sure to refer to Operation Manual of vacuum sensor for details before usage.)

Vacuum piping

- Inside diameter of hose at vacuum side ... $\phi 4$ mm or more
(A hose with one size larger diameter is recommendable if the length of the hose exceeds 2m.)
- Avoid to use elbow joints.
- Smaller diameter than specified for pipings and fittings causes pressure drop and insufficient flow volume, by which the vacuum performance is lowered and suction impossible.

Filter

- ⊙ To prevent foreign particles from pad not to enter into the inside of CONVUM.
- Periodical cleaning is required at appropriate interval to prevent clogging of filter by moisture fluid and other contaminants.

Air Cylinder

Vacuum pad

CAUTION

- * There must be no air leakage in the pipings for both of supply air and vacuum.
- * The wiring for the solenoid valves must be in accordance with the specifications.
- * Please refer to catalog as for specifications and outer dimensions.

Exploded View

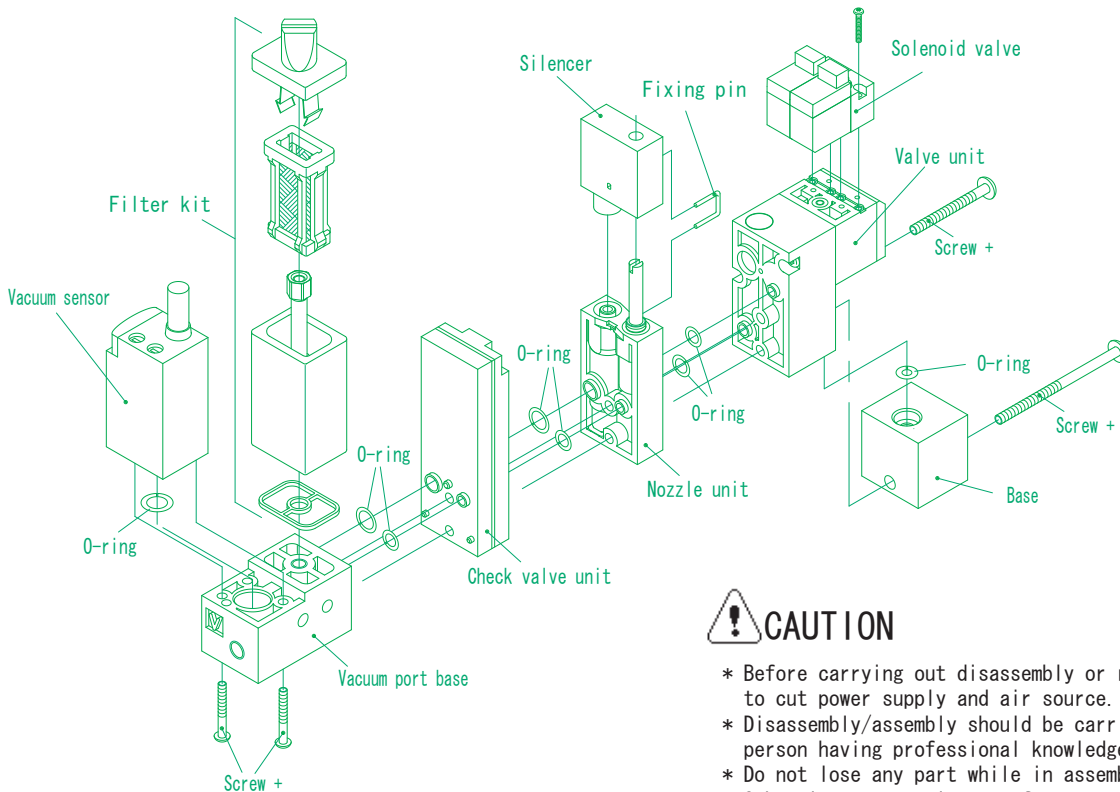

CAUTION

- * Before carrying out disassembly or replacing a part, be sure to cut power supply and air source.
- * Disassembly/assembly should be carried out strictly by a person having professional knowledge.
- * Do not lose any part while in assembly/disassembly work. Otherwise, appropriate performance can not be warranted.
- * As a spring part may fly during disassembly work, etc., be sure to take protective glasses.

CONVUM
<http://www.convum.co.jp>