

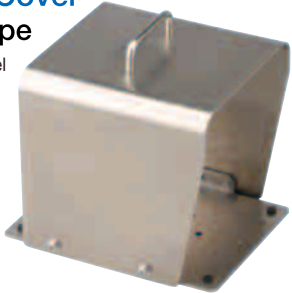

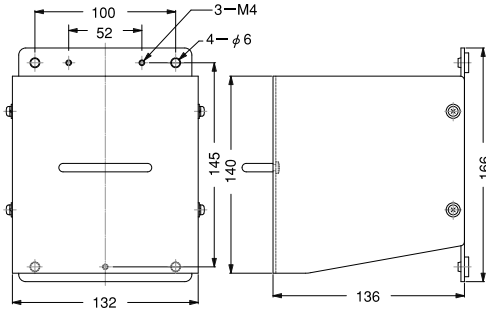

Protection cover and Attachment Base

Protection cover

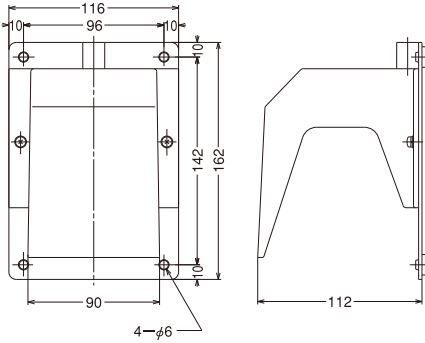

The product is a protection cover designed to provide protection against falling objects and to prevent malfunction caused by impacts.

Type	Dimension	Application type
<p>Protection Cover</p> <p>● OFL-CS Type</p> <p>Material: stainless steel Weight: 1,310 g</p>  <p>※ Different types call for different mounting screws. Please indicate the foot switch type being used when placing an order.</p>		<ul style="list-style-type: none"> ● OFL-<input type="checkbox"/> CS Type ● OFL-<input type="checkbox"/> -M4CS Type ● OFL-<input type="checkbox"/> -S5CS Type ● OFL-<input type="checkbox"/> -S6CS Type ● OFL-<input type="checkbox"/> -M6CS Type ● OFL-<input type="checkbox"/> -S7CS Type ● OFL-<input type="checkbox"/> -HCS Type ● OFL-<input type="checkbox"/> -PCS Type

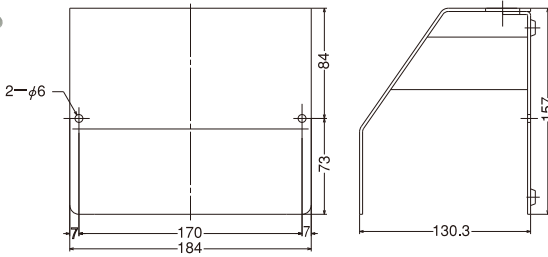
<p>Protection Cover</p> <p>● OFL-C Type</p> <p>Protection cover (w/ base)</p> <p>Material: aluminum Weight: 610 g</p> 		<ul style="list-style-type: none"> ● OFL-<input type="checkbox"/> -S3C Type ● OFL-<input type="checkbox"/> -M3C Type ● OFL-<input type="checkbox"/> -M4C Type ● OFL-<input type="checkbox"/> -S5C Type ● OFL-<input type="checkbox"/> -PC Type
--	---	---

<p>Protection Cover</p> <p>● OFL-TC Type</p> <p>2-position Cover</p> <p>Material: steel Weight: 1,500 g</p> 		<ul style="list-style-type: none"> ● OFL-TV-S3C Type ● OFL-TVG-S3C Type ● OFL-TVG5-S3C Type ● OFL-TV-M3C Type ● OFL-TV-M4C Type ● OFL-TV-FS2C Type
---	--	--

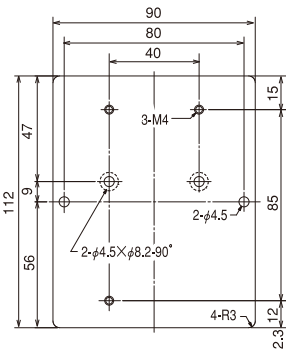
Attachment base

Type	Dimension	Application type
<p>Base</p> <p>● OFL-T2 Type</p> <p>Angular base</p> <p>Material: steel Weight: 180 g</p>  <p>※ The photo shows the OFL-1V-M3T2.</p>		<ul style="list-style-type: none"> ● OFL-<input type="checkbox"/> -S3T2 Type ● OFL-<input type="checkbox"/> -M3T2 Type ● OFL-<input type="checkbox"/> -M4T2 Type  <p>※ The photo shows the OFL-1V-M4T2.</p>