

HPL Series Background Suppression Sensors

FEATURES

The **HPL** Series can Detect the Minute Differential Difference of Very Small and Thin Objects, with no Effect of the Object's Color or Reflection.

- The world's smallest (12×14×27mm) built-in amplifier type background suppression photoelectric sensors.
- Superior detection of minute differential distances. (Able to detect one-tenth of the sensing distance of conventional models.)
- Can be mounted easily in any position or location using a dedicated mounting bracket.



ORDER GUIDE

Shape	Detection method	Scanning distance	Supply voltage	Output mode	Operation mode		Catalog listing
					Light ON	Dark ON	
	Background Suppression Sensors limited diffuse scan model	20 to 50mm	10 to 30Vdc	NPN Transistor output (with pull-up)	○	–	HPL-S1
					–	○	HPL-S3

SPECIFICATIONS

Detecting method	Limited diffuse scan	
	HPL-S1	HPL-S3
Catalog listing	HPL-S1	HPL-S3
Supply voltage	10 to 30Vdc (ripple 10% max.)	
Current consumption	30mA max.	
Scanning distance setting range	20 to 50mm	
Scanning distance range	5 to 50mm	
Detecting object	10 x 10cm Kodak 90% white paper	
Output mode	NPN transistor output (with 18kΩ pull-up resistor)	
Operation mode	Light ON	Dark ON
Control output	Open / close current: 100mA max. (resistive load) Output dielectric strength : 30V Voltage drop : 1.8V max. (at 100mA switching circuit)	
Response time	1ms max. (for operation and recovery)	
Light emitter	Red LED (Wave length: 660nm)	
Indicator	Light-receiving indication (Yellow at light-receiving) Stabilized light-receiving indication (Yellow blinking at stable light-receiving)	
Ambient light Immunity	Incandescent lamp: 10,000lx max. (intensity at light-receiving surface)	
Operating temperature range	– 10 to +50°C (no icing nor dew condensation allowed)	
Insulation resistance	20MΩmin. at 500Vdc megger	
Dielectric strength	500Vac (50/60Hz) for 1 minute between electrically live metals and case	
Vibration resistance	10 to 55Hz, 1.5mm peak-to-peak amplitude, 2 hours each in X, Y and Z directions	
Shock resistance	500m/s ² 3 times each in X, Y and Z directions	
Protective structure	IP65 (IEC 144)	
Wiring method	Pre-leaded	
Others	Power reverse polarity wiring protection and output short-circuit protection	

- Installation Instructions No.: CP-UM-5178E

CHARACTERISTICS DIAGRAMS (typical examples)

Operating range characteristics

(unit: mm)

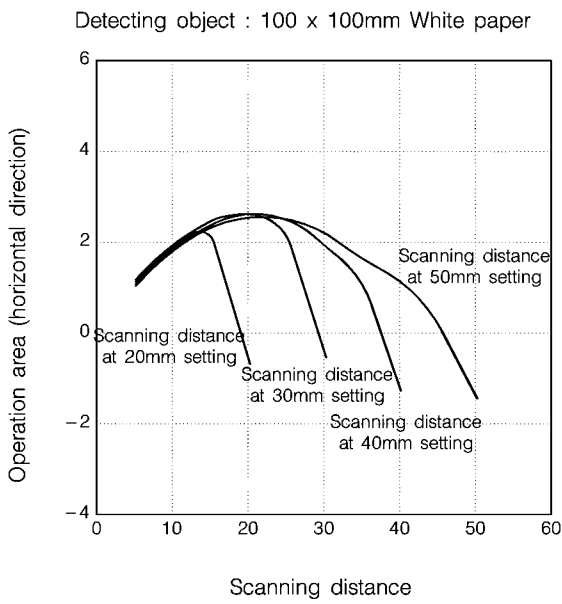

Detection object / scanning distance characteristics

Scanning distance at 20mm setting

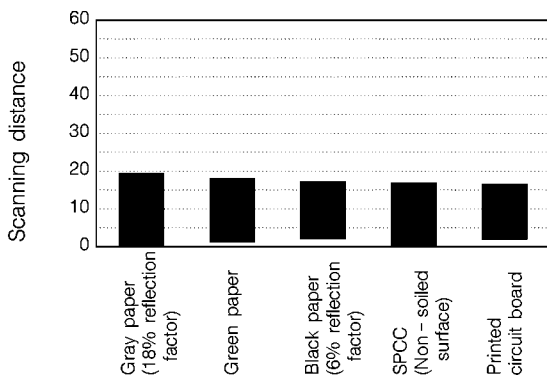

Scanning distance at 30mm setting

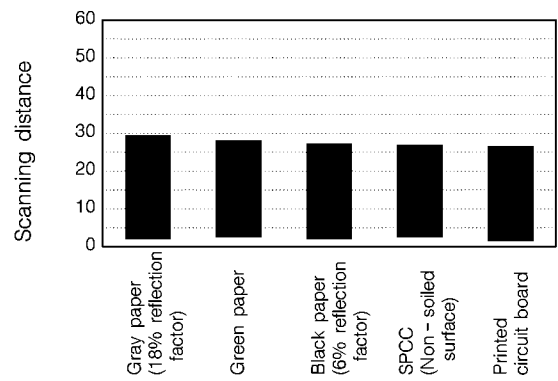

Scanning distance at 40mm setting

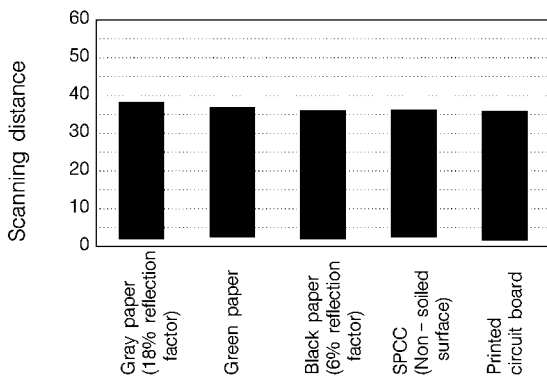

Scanning distance at 50mm setting

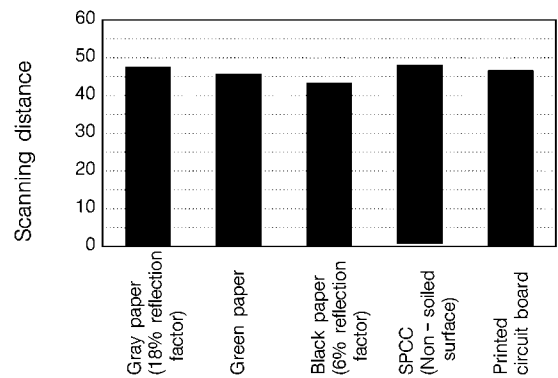

EXTERNAL DIMENSIONS

● Amplifier unit

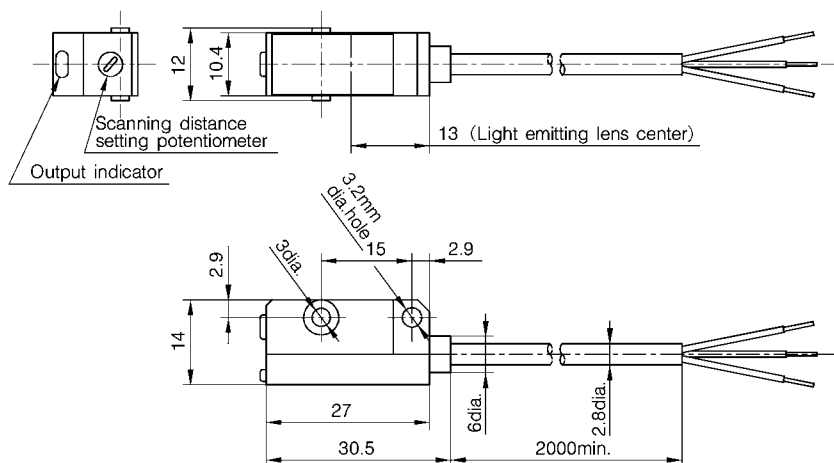

● Bracket

(unit: mm)

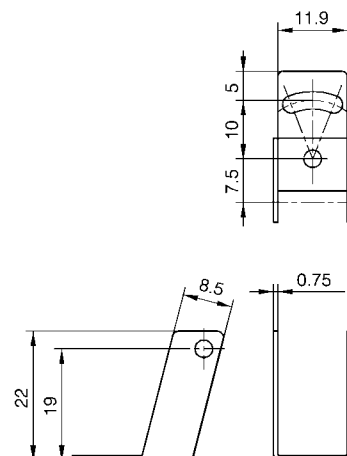

● Bracket mounting examples

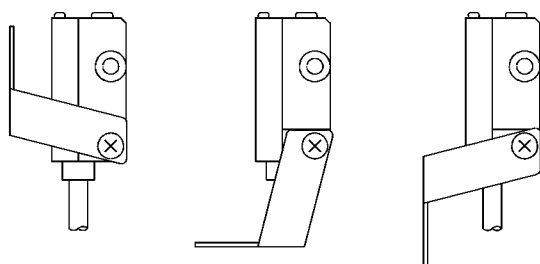

OUTPUT CIRCUIT

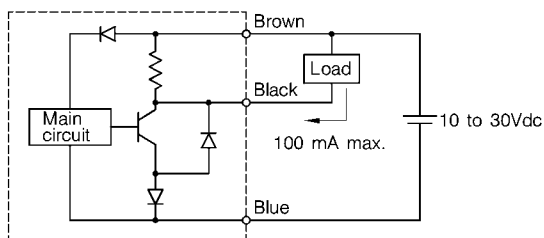

SENSITIVITY ADJUSTMENT

● Distance setting method

- (1) Adjust the scanning distance setting potentiometer to the minimum setting distance by turning it counterclockwise.
- (2) Place a detection object at the scanning position, and turn the scanning distance setting potentiometer gradually clockwise until the operation indicator is ON. This position is determined as position A.
- (3) Take the detection object away, and gradually turn the potentiometer further clockwise from position A until the operation indicator is ON, and the turning is stopped once. And then, gradually turn the potentiometer back counterclockwise until the operation indicator is turned OFF. This position is determined as position B. If the operation indicator does not go ON even when the scanning distance setting potentiometer is set at the maximum distance, this position is designated as B.
- (4) Set the scanning distance setting potentiometer in between positions A and B.

BASIC PRECAUTIONS

● Mounting

- Avoid strong light beams such as sun light, fluorescent lamp and incandescence lamp on the sensing surface of the photoelectric sensors.
- Be careful for the mounting direction of the sensor against the moving direction of the detecting object.

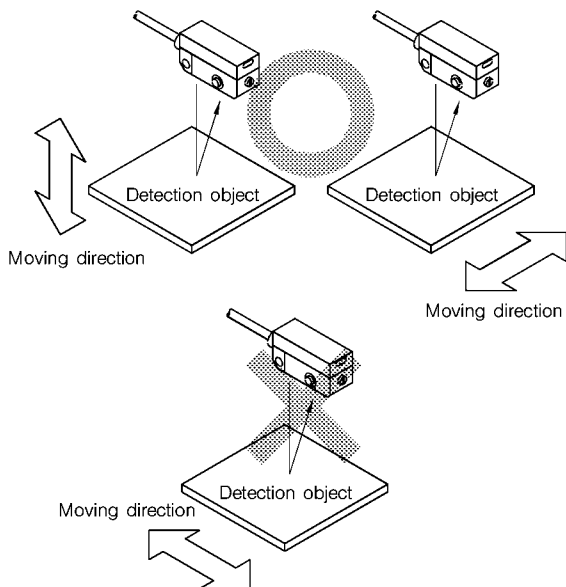

- Take care for the mounting direction when the color or surface condition is extremely changeable.

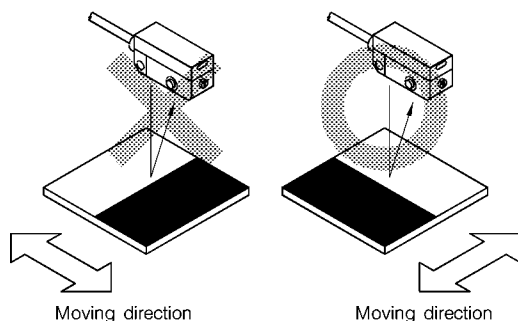

- Use the sensor in a way that the sensing surface of the sensor and the detection object surface are parallel. (The object must not be at a slant.)

● Wiring

- When extending cords, use a 0.3mm² min. cable. Keep the cable length to within 100m.
- Route the cord separately from power lines or through an exclusive conduit. Otherwise, electrical noise or power surge may cause incorrect operation or damage.
- If a switching regulator is used for the power supply, connect the frame ground and ground terminal to the earth. When the sensor is used without grounding, faulty operation may occur due to the switching noise.
- When using a load which generates rush current above the allowable output current (e.g. capacitive load, incandescent lamp load), connect a current-limiting resistor between the load and the output. (Otherwise, the output short-circuiting protection function may operate.)

● Handling

- Tighten the mounting screw for case at a torque less than 0.5N·m.
- Do not bend the part of the cord nearest to the photoelectric sensor within a minimum radius of 20mm. Also, avoid applying continuous bending stress.
- The time required for stabilizing the operation is approx. 0.1s after power ON.
- Avoid use in locations subject to large vibrations or shock, and do not use outdoors
- Prevent water or oil from splashing on the photoelectric sensor.
- Do not tug the cord with more than 30N force.
- Do not use in atmosphere with chemicals (organic solvents, acid, alkali, etc.).
- If lens is soiled, wipe with a soft, clean cloth or with a damp cloth. Do not use any organic solvents such as benzene, acetone and paint thinner.
- Be careful of mutual interference when two or more photoelectric sensors are use in close proximity. Make sure to check the individual operation before starting.



RESTRICIONS ON USE

This product has been designed, developed and manufactured for general-purpose application in machinery and equipment. Accordingly, when used in applications outlined below, special care should be taken to implement a fail-safe and/or redundant design concept as well as a periodic maintenance program.

- Safety devices for plant worker protection
- Start/stop control devices for transportation and material handling machines
- Aeronautical/aerospace machines
- Control devices for nuclear reactors

Never use this product in applications where human safety may be put at risk.

YAMATAKE

Yamatake Corporation
Advanced Automation Company

International Business Headquarters

Totate International Building
 2-12-19 Shibuya Shibuya-ku
 Tokyo 150-8316 Japan
 URL: <http://www.yamatake.com>

Specifications are subject to change without notice.

This has been printed on 100% recycled paper.

(01)

Printed in Japan (SP)

1st Edition: Issued in Apr., 2002

2nd Edition: Issued in Oct., 2003