

HPQ-D Series

Optical Liquid Leak Detectors with Self-contained Amplifier

FEATURES

High-Speed Detection, Space Saving and Easy-to-Maintain Leak Detectors.

- *Refractive detection system ensures sufficient gain signal difference between light-ON and dark-ON light levels. (approx. ten times)*
- *Easy maintenance as the body can be mounted or dismantled by single touch operation.*
- *High-speed detection because of the unique structure that the liquid can be promptly entered to the detector surface from any direction. (360°)*
- *PFA is used for wetted material and is applicable to all chemical applications.*
- *Compact sensor head type with its size of only 10mm height and 23mm diameter offers advantages for effective space saving.*
- *Easy initial setting as it does not require sensitivity adjustment.*
- *Sensor status can be confirmed at a glance.*
(Normal condition: Green LED ON, Liquid leakage: Orange LED ON)

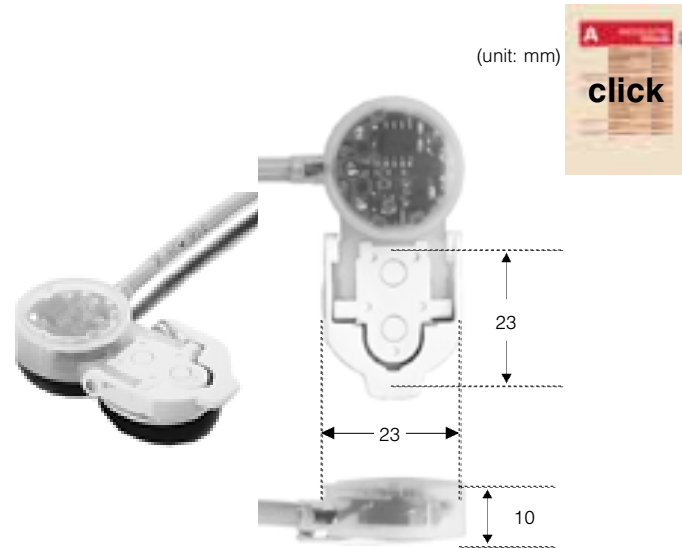

For the detail dimensions, refer to the drawings.

TYPICAL APPLICATIONS

- Semiconductor production equipment
- Chemical production equipment
- Film production equipment
- AV tape production equipment
- Dry cell production equipment
- Discrete electronic component production equipment

ORDER GUIDE

Detection method	Output mode	Catalog listing
Light refraction system	NPN transistor (open collector)	HPQ-D11
	PNP transistor (open collector)	HPQ-D12

Note: Code: 2m

SPECIFICATIONS

Catalog listing		HPQ-D11	HPQ-D12
Supply voltage		12 to 24Vdc ± 10% (ripple voltage 10% max.)	
Current consumption		30mA max.	
Mounting face		Polyvinyl chloride plate, stainless steel plate, etc.	
Standard target object		Water Note.	
Operation mode		Normal condition: ON, Liquid leakage: OFF	
Output mode		NPN transistor output, open collector	PNP transistor output, open collector
Control output	Switching current	50mA max. (resistive load)	
	Voltage drop	1V max. (at 50mA switching current)	
	Output dielectric strength	30V, with an output short-circuit protection circuit	
Light emitter		Red LED (645nm)	
Indicator		Green light ON at normal condition. Orange light ON at liquid leakage.	
Operating temperature range		-25 to +50°C	
Storage temperature range		-40 to +70°C	
Operating humidity range		35 to 85%RH (no condensation allowed)	
Insulation resistance		20MΩ min. (by 500V megger)	
Dielectric strength		1,000Vac 50/60Hz for 1 minute between case and electrically live metals	
Vibration resistance		10 to 55Hz, 1.5mm peak-to-peak amplitude, 2 hours in X, Y and Z directions	
Shock resistance		500m/s ² , 3 times in X, Y and Z directions	
Protection		IP50 (IEC 529)	
Others		Output is disabled during power ON. Output reverse connection protection circuit.	

• Installation Instructions No.: CP-UM-5280E

Note 1: Operation may become unstable depending on the mounting surface color or surface condition.

Note 2: If a target object for detection liquid other than the one specified, contact Yamatake Corporation in advance.

EXTERNAL DIMENSIONS

(unit: mm)

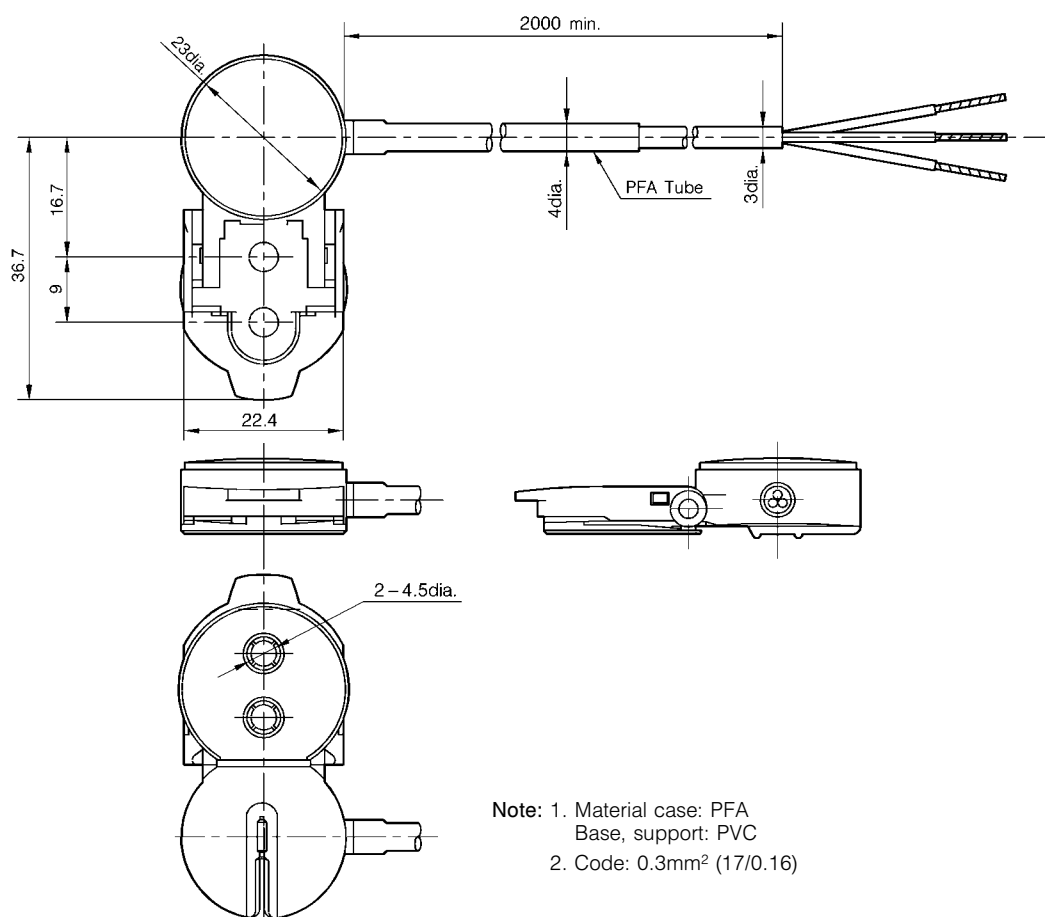

OUTPUT CIRCUIT DIAGRAM

● HPQ-D11 (NPN type)

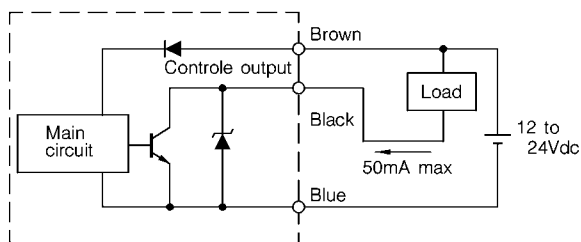

● HPQ-D12 (PNP type)

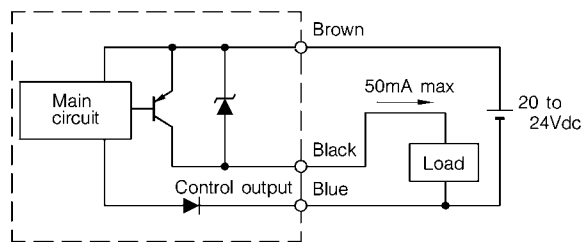

MOUNTING METHOD

Mount the sensor horizontally. After locking the mounting plate in position, insert the sensor body onto the mounting plate and fix it by tilting down the locking clasp of the sensor.

● Screw fastening

Remove the knock-out holes of the mounting base, and insert two 4mm dia. screws and fasten the sensor with two 4mm dia. nuts.

(unit: mm)

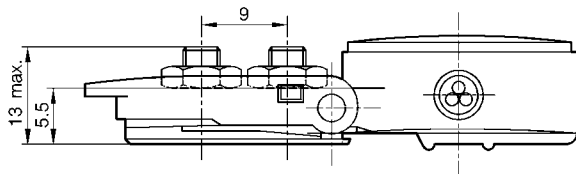

Handling Precautions

- The recommended tightening torque is 0.5N·m max.
- Verify that the amount of thread protruding from the mounting face doesn't exceed 13mm. Otherwise, the thread will interfere with the locking clasp and could affect locking the sensor body into position.

HANDLING PRECAUTIONS

● Precautions on installation and wiring

- Turn off the power supply before mounting or removing the sensor.
- Never use this sensor for applications being constantly exposed to a liquid.
- The presence of air bubbles on the sensing area of the sensor may result in unstable detection.
- If an extension of cord is necessary, use a 0.3mm² (minimum) cable of a length of 100m maximum.
- When using a commercially bought switching regulator, ground the flame ground terminal. Otherwise, the switching noise may result in detection errors.
- Approximately 50ms is required to reach to stable operation after the power is turned on.
- Route the wires of the sensor separately from power lines or through an exclusive conduit. Otherwise, an electrical surge may result in the malfunction of the sensor or cause damage to the device.

- Application of spring washer or adhesives is recommended to protect the sensor from loosening when used in high temperature environment.

● Attachment using adhesives

Use an appropriate adhesive and glue the mounting base.

Handling Precautions

- Apply a thin coating of the adhesive uniformly. Too much adhesive will cause the detecting face to float.
- Make sure no adhesive seeps from the edges.
- If any adhesive seeps from the sensor body, there may be difficulty mounting or removing the sensor. In addition, such a condition may interfere with the detecting capabilities of the device.

- Errors may occur if any liquid is on the sensing face or if the sensing face is scratched.

- If the cord is strongly pulled out by pulling around, etc., after mounting the sensor body, it may be dislocated from the mounting base. Make sure to check once again if the sensor is firmly attached after cord wiring.

● Maintenance

- When the **HPQ** Series becomes dirty, wipe clean with the soft and dried cloth.
- Mounting base and locking clasp are made of PVC. Do not apply any organic solvents such as benzene, acetone and thinner to avoid affecting the device's color change or to avoid any possible damage.

● Disposal

- Absolutely don't incinerate this product. It is made of PFA and PVC substances that expel poisonous gases when burnt.
- When the **HPQ** Series is to be scrapped, follow all applicable local industrial waste codes.

HPQ-T Series

Pipe Mounting Type Liquid Level-Sensor with Self-contained Amplifier

FEATURES

Detection of Liquid Level in Non-contact Manner Achieved Merely by Mounting Sensor on Pipe.

- Almost no malfunction caused by bubbles or water
- Output mode selectable for the presence or non-presence of liquid
- Operation section is located on side panel.
Indicator lamp is easy-to-view even when sensors are gang-mounted.
Output selector switch can be operated even when sensors are gang-mounted.
- Built-in malfunction prevention circuit at power ON and reverse connection protection circuit

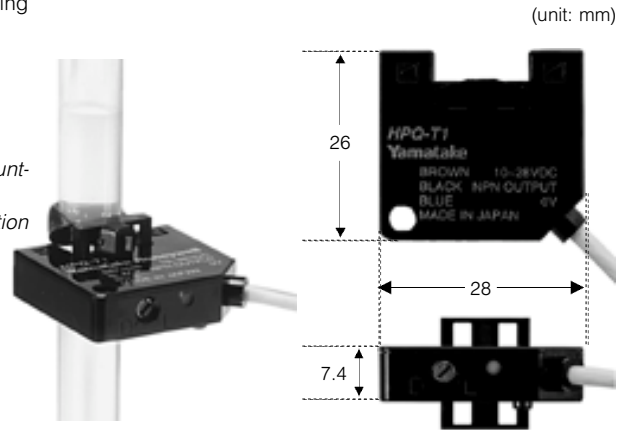

For the detail dimensions, refer to the drawings.



TYPICAL APPLICATIONS

- Detection of liquid tank level
 - Detection of liquids in feeder pipes
- Mounting in the above applications allows stable detection of liquid levels.

Semiconductor production equipment
Chemical production equipment
Film production equipment
AV tape production equipment
Dry cell production equipment
Discrete electronic component production equipment
Photo print development equipment
Food processing machinery

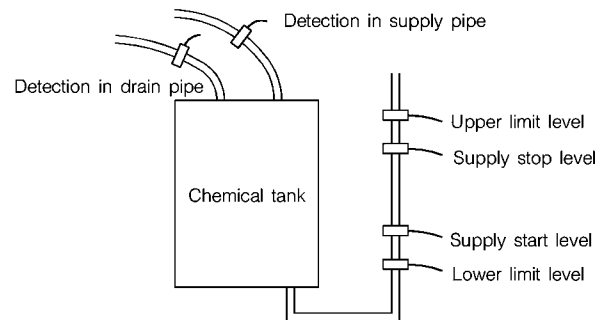

CATALOG LISTING

Detection method	Applicable pipe diameter	Output mode	Catalog listing
Pipe mounting type	8 to 13mm dia.	NPN transistor open collector	HPQ-T1

Note: Cord: 2m

SPECIFICATIONS

Item		Details
Detection method		Pipe mounting type liquid level detection
Supply voltage		10 to 28Vdc (ripple voltage 10% max.)
Current consumption		25mA max.
Applicable pipe diameter		8 to 13mm dia. 1mm thick (Note)
Applicable pipe materials		PFA: Fluorocarbon resin/glass (Note)
Applicable medium		Transparent or non-transparent liquid (Note)
Detection hysteresis		1mm max.
Operation mode		Light ON (L-ON)/Dark ON (D-ON), selected by switch at liquid detection: Dark, at liquid non-detection: Light
Output mode		NPN transistor, Open collector type
Control output	Switching current	100mA max. (resistive load)
	Output dielectric strength	30V
	Voltage drop	1V max. (at 100mA switching current)
Response time		2ms max. (for operation and release)
Light emitter		Red LED (peak emission wavelength 950nm)
Display functions		Operation indicator: Red (lit at output ON)
Ambient light immunity		1,000lux max. (incandescent lamp)
Operating temperature range		-10 to +55°C
Storage temperature range		-25 to +70°C
Operating humidity range		35 to 85%RH (condensation not allowed)
Insulation resistance		Min. 20MΩ (by 500Vdc megger)
Dielectric strength		1,000Vac, 50/60Hz for 1 minute between case and electrically live metals 500Vac, 50/60Hz for 1 minute, at L-ON/D-ON selector switch
Vibration resistance		10 to 55Hz, 1.5mm peak-to-peak amplitude, 2 hours in X, Y and Z directions
Shock resistance		500m/s ² , 3 times in X, Y and Z directions
Protection		IP50 (IEC 529)
Circuit protection		Built-in reverse connection protection circuit, malfunction prevention circuit at power ON (approx. 20ms), output short-circuit protection
Accessories		Bundling band and silicon tube (2 of each)

- Installation Instructions No.: CP-UM-3144E

Note: As there might be a case that stable detection can not be performed according to transmittance or refractive index of a pipe or water actually applied, use after carefully checking the operation.

EXTERNAL DIMENSIONS

(unit: mm)

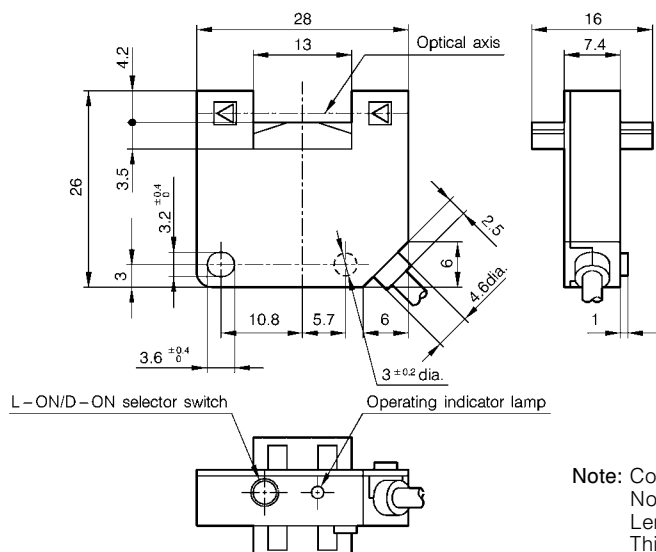

OUTPUT CIRCUIT DIAGRAM

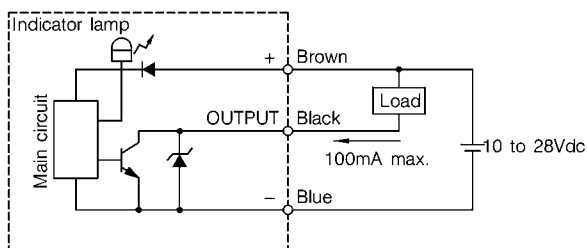

MOUNTING

This liquid level sensor is mounted onto pipes by either an M3 screw or bundling band (supplied).

When mounting the sensor by the bundling band, be sure to tighten the sensor by passing the silicon tube through the bundling band (supplied) to prevent the sensor from slipping.

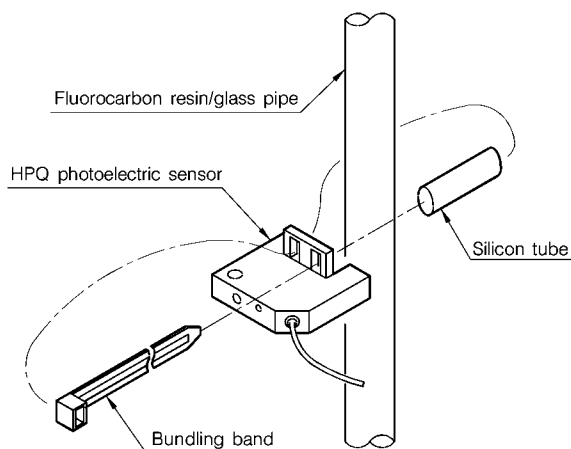

• What is the “transmission refraction system”?

As shown in the diagram below, light is detected using changes in the refractive index caused by the liquid. When there is no liquid, light is ON.

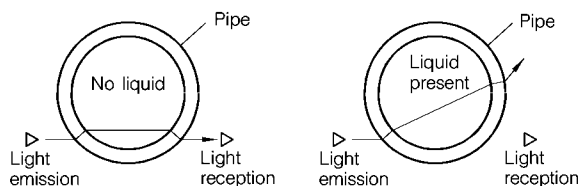

PRECAUTIONS UPON USE

• Handling

- Output is disabled upon power-up approx. 20ms so that stabilization occurs.
- In applications where untransparent pipes are used, the detection accuracy may fall.
- Water droplets or bubbles in the pipes may cause incorrect operation.
- In case of high-viscous or colored liquids, the detection may fall.
- In installing the sensor with loosen, the detection accuracy may fall. Install this sensor to the pipe tightly, using the attached cord ties and anti-slip tubes.
- When installing the sensor with screws, use M3 screws, plain washers, and spring washers. And applicable tightening torque is 0.6N-m.
- This sensor is not of water-proof structure.
- The polycarbonate used for the housing may be damaged when exposed to organic solvents, acids or alkalis. Keep chemicals like these away from the sensor.
- Cord-cut may occur when cord is pulled with over 30N.
- This sensor can not be used outdoors.

• Wiring

- If an extension of cord is necessary, use a 0.3mm² minimum cord of 100m maximum length.
- Route the wires of the sensor separately from power lines or through an exclusive conduit, otherwise the electrical surge may cause incorrect operation or damage.
- When using a commercially available switching regulator, ground the FG (frame ground) and G (ground) terminals, otherwise the switching noise may cause incorrect operation.
- When using a load which generates a transient current, connect a current limiting resistor between the load and the output terminal, otherwise the short circuit protection may function.

HPF Series Fiber Units for Wet Process



FEATURES

Entirely Protected with Chemical-proof Resin for Reliable Use in Chemicals or Oils.

Usable in Explosive Atmosphere.

(Install the Amplifier in Non-explosive Atmosphere.)

ORDER GUIDE

● Leak detection fiber: HPF-D040

Model	Shape	Scanning distance	Features	Catalog listing
Leak detection		Leak is detected by contact of the sensor tip with the liquid.	Refractive detection system ensures sufficient gain signal difference between light-ON and dark-ON light levels. The body can be mounted or dismounted by single touch. Bend-resistant and corrosion-resistant integral PFA molding fiber cable is adopted. Cable length: 5m, Min. bending radius: 20mm.	HPF-D040

● Pipe mounting type, liquid surface detection fiber: HPF-T032

Model	Shape	Scanning distance	Features	Catalog listing
Liquid surface detection (Pipe mounting type)		Used by mounting on a pipe (or tube)	For use with 3 to 13mm dia. pipes. Refractive detection system ensures sufficient gain signal difference between light-ON and dark-ON light levels. Array type of reducing influence of bubbles or water. Bend-resistant and corrosion-resistant integral PFA molding fiber cable is adopted. Cable length: 5m, Min. bending radius: 4mm.	HPF-T032

● Tank insertion type, liquid surface detection fiber

Model	Shape	Scanning distance	Features	Catalog listing
Liquid surface detection (Tank mounting type, 6dia. type)		Liquid surface is detected by contact of the sensor tip with the liquid surface.	Contact type (6mm dia.): Uses a proprietary tip structure that prevents liquid build-up to stably detect liquid surfaces. Heat-resistance temperature 105°C, Min. bending radius: 40mm.	HPF-D027
Liquid surface detection (Tank mounting type, 4dia. type)			Contact type (4mm dia.): Uses a proprietary tip structure that prevents liquid build-up to stably detect liquid surfaces. Heat-resistance temperature 105°C, Min. bending radius: 30mm.	HPF-D033

● Chemical-proof fiber

nL: Standard mode, HP: Long distance mode, HS: High speed mode

Model	Shape	Scanning distance (mm)		Features	Catalog listing
		Combination mode			
Thru scan type Chemical-proof Side view		HPX-NT	nL	Side view type chemical-proof and oil-proof. Fluorine coated fiber. Min. bending radius: 80mm.	HPF-T027
			HP		
Thru scan type Chemical-proof Small diameter		HPX-ET	HS	R 20mm bend type chemical-proof and oil-proof. Directly connectable to amplifier unit by cutting the fluorine resin tube and fiber cable at the same time. (at use of HPX-NT/ET)	HPF-T029
			nL		
Diffuse scan type Chemical-proof		HPX-NT	nL	Fluorine coated. Fiber type oil-proof and chemical-proof. Min. bending radius: 80mm.	HPF-D014
			HP		
		HPX-ET	HS		

Note: Capability value is shown. Actual scanning distance is limited by fiber length (standard 2m × 24m).

EXTERNAL DIMENSIONS

(unit: mm)

- Leak detection fiber
- **HPF-D040**

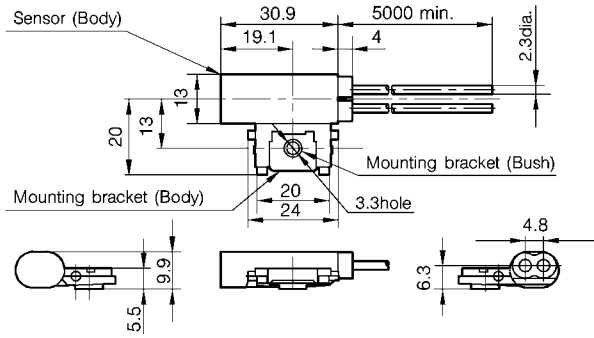

- Tube mounting type liquid surface detection fiber
- **HPF-T032**

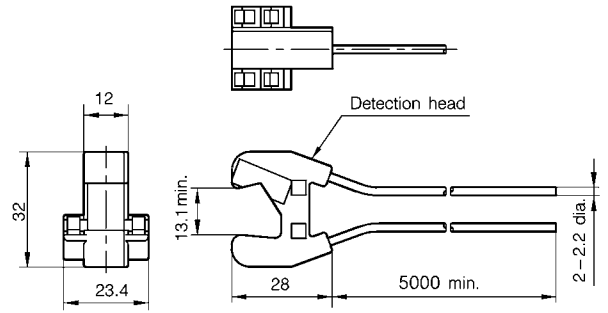

- Tank insertion type liquid surface detection fiber
- **HPF-D027**

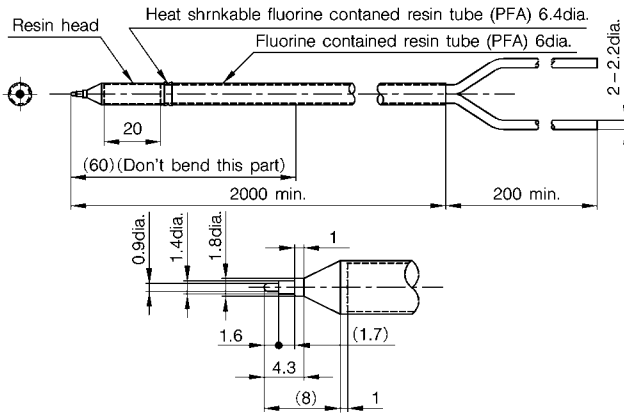

- **HPF-D033**

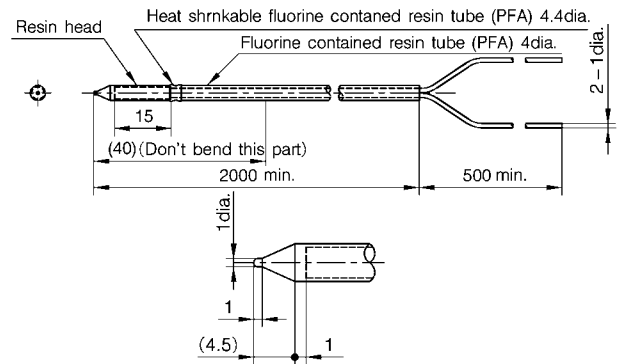

- Chemical-proof fiber
- **HPF-T027**

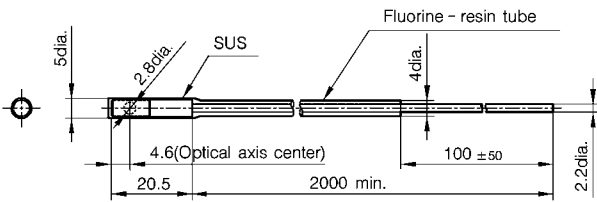

- **HPF-T029**

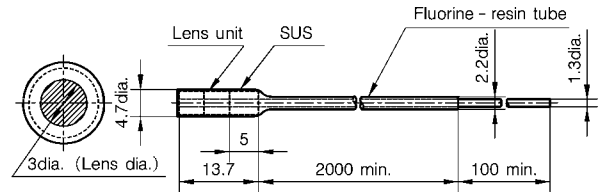

- **HPF-D014**

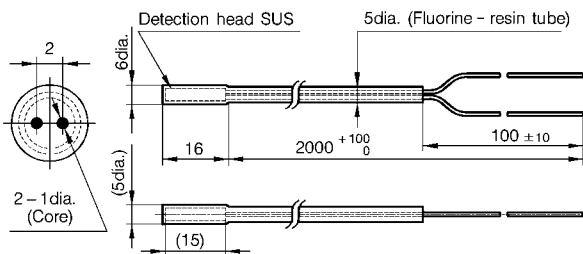

HANDLING PRECAUTIONS FOR FIBER UNITS

• General handling precautions

Fiber units are very sensitive to mishandling. Improper handling may lead to unexpected failure. Take the following precautions when handling fiber units:

- Do not impact or damage the sensing head.

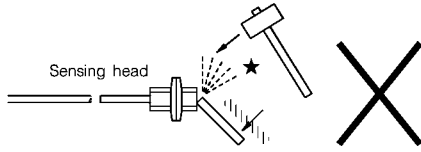

- Do not bend or apply excessive force to the fiber elements.

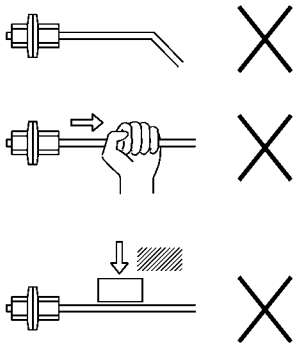

- Do not subject the sensing head to excessive torque.

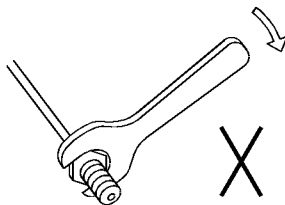

- When a fiber unit is used in a location subject to vibration, secure it tightly. Take special care to ensure that the coupling between the fiber unit and the amplifier unit.
- When bending a fiber unit, bend at a radius larger than the minimum bending radius.
- The scanning distance of fiber optic photoelectric sensors may be 20% shorter depending on their fiber cut-off state and the state of the connection with the amplifier unit. We recommend using fiber optic photoelectric sensors at 80% or less of their scanning distance.

• Handling precautions by type

HPF-T027/-T029/-D014 mounting method

- For mounting the fiber unit, use a commercially available fluorine-resin joint which matches with the outside diameter of PAF tube.

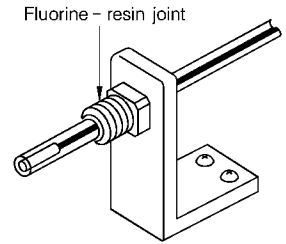

- The bending radius of a protective tube must be more than the minimum bending radius specified for each fiber unit.

Take precautions to ensure that the bending radius is larger than the minimum bending radius at anytime to avoid damages to the fiber unit

- Do not apply any excessive pulling force.

HPF-D027/-D033 mounting method

- For mounting the fiber unit, use a commercially available fluorine-resin joint which matches with the outside diameter of PAF tube.

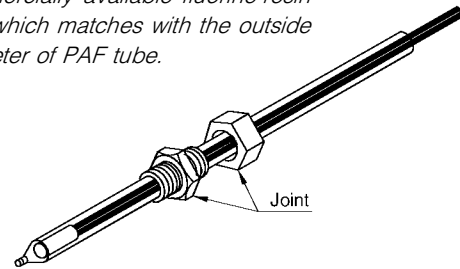

HPF-D040 mounting method

- When using a SUS mounting base, insert the welded M3 stud bolt into the hole of the mounting base, and then mount with the M3 nut (to be prepared separately).
- Set the convexes of the dedicated mounting base provided for the housing into the concaves of the fiber unit, and then slide it forward until it is fixed.

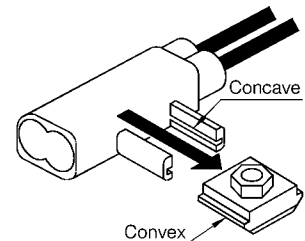
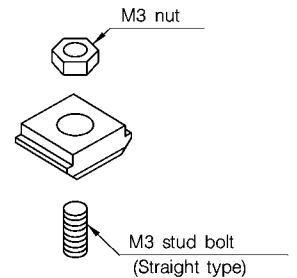

HPF-D040 mounting method

- As shown below, mount the fiber unit by using the attached bundling bands and anti-slip tubes. Firmly tighten the two upper and lower bundling bands, and then cut the excessive portions of the bundling bands.

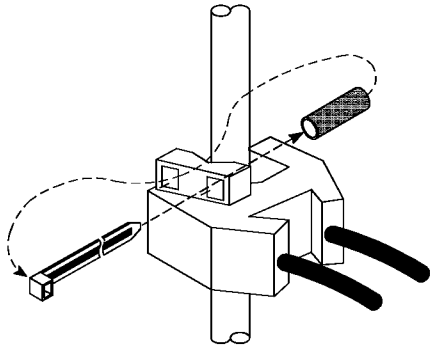

- If an additional bundling band is required, use the bundling band of which "A" dimension shown in the figure below is 2.5mm max.

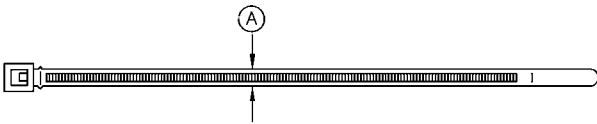

RESTRICIONS ON USE

This product has been designed, developed and manufactured for general-purpose application in machinery and equipment. Accordingly, when used in applications outlined below, special care should be taken to implement a fail-safe and/or redundant design concept as well as a periodic maintenance program.

- Safety devices for plant worker protection
- Start/stop control devices for transportation and material handling machines
- Aeronautical/aerospace machines
- Control devices for nuclear reactors

Never use this product in applications where human safety may be put at risk.

YAMATAKE

Specifications are subject to change without notice.

Yamatake Corporation
Advanced Automation Company

International Business Headquarters

Totate International Building

2-12-19 Shibuya Shibuya-ku

Tokyo 150-8316 Japan

URL:<http://www.yamatake.com>

This has been printed on 100% recycled paper.

(01)

Printed in Japan (SP)

1st Edition: Issued in Aug., 2003

2nd Edition: Issued in Oct., 2003