

# QRC Series Super Smooth Compliance Device

## Super Smooth, Light-Weight, and Compact Compliance Device

### Key Features

- Super smooth sliding via ball guide
- Center retention (air lock function to return precise returning to the datum position as well as retention of the center).
- Light-weight and compact (available from 0.5kg payload limit)



QRC-1.5A

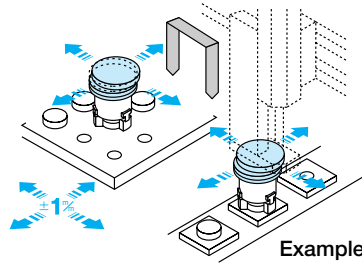

Example of Use

### How To Order

Standard ----- **QRC-0.5A**

Option ----- **QRC - 0.5A - Z**

Size		Option	
Symbol		Symbol	Name
0.5A		Z	Special Type (Custom)
1.5A			
6A			

For option detail ▶ 36▶

### Specification

Model		QRC-0.5A	QRC-1.5A	QRC-6A
Working Pressure		Pneumatic: 0.3 to 0.7MPa		
Lubrication		Not Required or Turbine Oil Class 1 (ISOVG32)		
Ambient Temperature (°C)		5 to 60		
Moving Range	X-Y Direction (mm)	±1	±1	±2
	Twisting Direction ( $\alpha$ )	±2.5°	±2°	±3.5°
Repeatability	X-Y Direction (mm)	±0.02		
	Twisting Direction ( $\alpha$ )	±0.1°		
Load Capacity	Tensile Direction (N)	39	68	266
	Compression Direction (N)	62	111	444
	Bending Moment (N·m)	0.5	1.3	7.6
Payload Limit (kg)		0.5	1.5	6
Weight (kg)		0.1	0.27	0.65

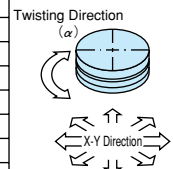

## Layout Drawing

For CAD data, please go to **▶518P**

### ■QRC-0.5A

#### QRC-0.5A Standard

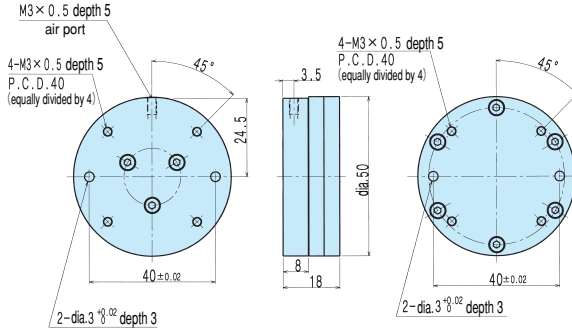

### ■QRC-1.5A

#### QRC-1.5A Standard

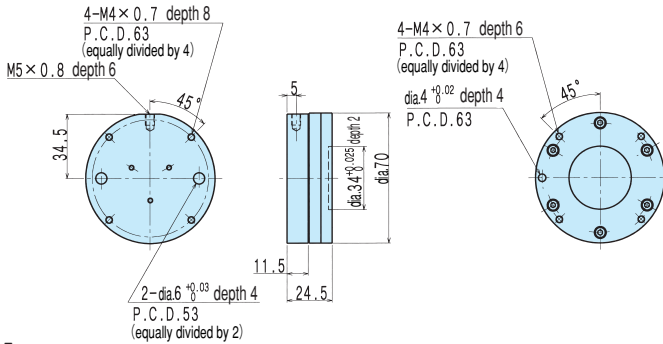

### ■QRC-6A

#### QRC-6A Standard

