

NBC Series 2-Row Conveyor

2-Row Non-Slip Conveyor Suitable for Transferring Pallets

Key Features

- 2-row Conveyor with 2 timing belts suitable for transferring pallets and wide workpieces
- 2 types of belt width: 25mm and 38mm
- One belt can be used as non-slip single belt conveyor
- Compatible with top roller chain type in addition to timing belt type
- Drive part can be mounted in arbitrary location

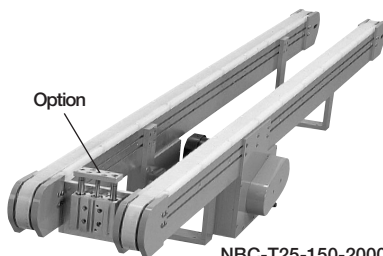

How To Order

Option ----- **NBC - T25 - 150 - 1000 - Z** -----

Belt Width & Chain
Pitch between Belts
Distance between Shafts
Option

2-row conveyor with the following belt specifications: belt width of 25, pitch between belts of 150, and unit length of 1000.

Belt Width & Chain	
Symbol	Specification
T25	Belt Width 25mm
T38	Belt Width 38mm
R	Chain

Pitch between Belts	
Symbol	Specification
150	150mm
200	200mm
300	300mm

Distance between Shafts
Specification
600~3000mm

Option	
Symbol	Name
Z	Special Type (Custom)

For option detail ▶ 36P

Specification

Model	NBC-T25·T38	NBC-R
Power Source	AC100V Single Phase	
Drive Motor	Compact Induction Motor 60W	
Belt Width (mm)	25·38	Chain
Pitch between Belts * (mm)	150·200·300	
Distance between Shafts (mm)	600 to 3,000	
Motor Speed (m/min)	2.4 to 20	
Maximum Transfer Mass (kg)	40	

*Please contact us for in-between width

Layout Drawing

■NBC-T

NBC-T25 Standard

*Values inside () are for T38.

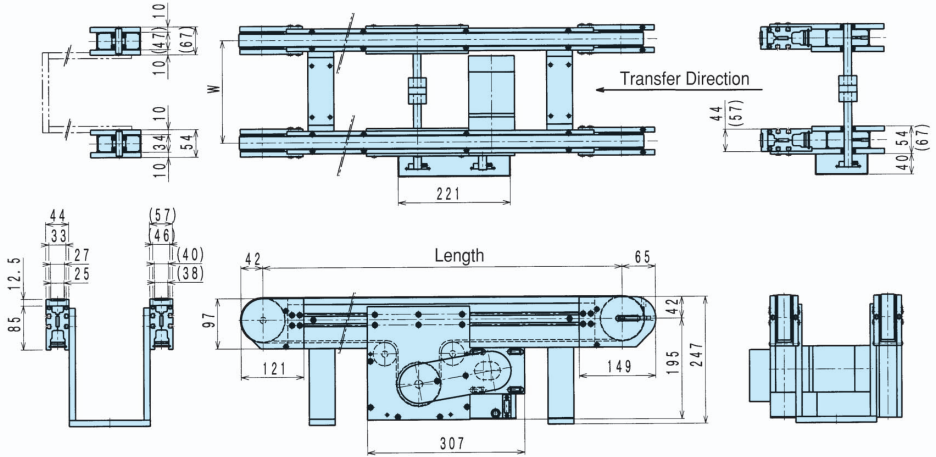

■NBC-R

NBC-R Standard

