

External Finger NA · NB

Please Contact Us for External Fingers

Key Features

External fingers (soft jaws) are available for various models. They can be machined according to the customer's workpieces.

■Machined spigot

Dowel (Spigot) area has been pre-machined. Available for various workpiece shapes and dimensions

■External fingers are available in 2 types of materials.

Iron (S50C) and engineering plastic (MC nylon) are available by environments

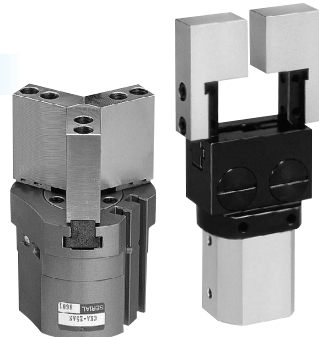

CKA-25AS

HA-3MS

Models Compatible with Standard External Fingers

Hand (2-Jaw Gripper)

- HA Type ●HE Type ●HB Type
- HMA Type ●BHA Type ●BHG Type
- HK Type ●HC Type ●HMB Type

Chuck

- CK Type ●CKA Type
- CKG Type ●CKL Type
- CKF Type ●CKS Type

How To Order

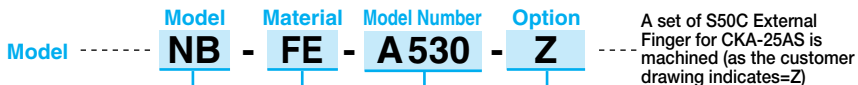

| Model | |
|--------|--------------|
| Symbol | Name |
| NA | Hand |
| NB | Chuck Series |
| | |
| | |
| | |

| Material | |
|----------|---------------------|
| Symbol | Name |
| FE | S50C |
| MC | Engineering Plastic |
| | |
| | |
| | |

| Model Number |
|---------------------|
| Specification |
| Refer to Each Chart |
| |
| |
| |

| Option | |
|--------|-----------------------|
| Symbol | Name |
| Z | Special Type (Custom) |
| | |
| | |
| | |

For option detail ▶ 36P

*Since this product is a soft jaw, we can machine its shape based on the drawing provided to us by customer's request.

Specification

■ Description of Hand (2-Jaw) Type

| External Finger Name | Type | Quantity / Set | Material | Dowel (Spigot) | Shape | Applicable Hand Model |
|----------------------|-----------------------|----------------|------------------------|----------------|-------------------------|--|
| NA (Soft Jaw) | 1 Type for Each Model | 2 pieces / Set | S50C or MC Nylon | Yes | Refer to Layout Drawing | HA Series HA-1M·2MS·3MS·4MS (The dimensions of HB are the same as those of HA) HC Series HC-2MS·3MS·4MS HE Series HE-2.5MS·3.5MS·4MS·5MS HMA Series HMA-01AS·02AS·03AS·04AS·05AS HMB Series HMB-01AS·02AS·03AS·04AS BHA Series BHA-01AS·03AS·04AS·05AS (The dimensions of BHG are the same as those of BHA) HK Series HK-32MS·40MS |

■ Description of Chuck (3-Jaw) Type

| External Finger Name | Type | Quantity / Set | Material | Dowel (Spigot) | Shape | Applicable Chuck Model |
|----------------------|-----------------------|----------------|------------------------|----------------|-------------------------|---|
| NB (Soft Jaw) | 1 Type for Each Model | 3 pieces / Set | S50C or MC Nylon | Yes | Refer to Layout Drawing | CKA Series CKA-15AS·20AS·25AS·30AS·40AS (The dimensions of CKF are the same as those of CKA) CK Series CK-1AS·1.5AS·2AS CKG Series CKG-16AS·25AS·32AS·40AS·50AS CKL Series CKL-20AS·25AS·32AS·40AS·50AS· 63AS·80AS·100AS CKS Series CKS-08AS·12AS·16AS·20AS·25AS· 32AS |

Example of External Fingers in Use

Example of Hand (2-Jaw) in Use

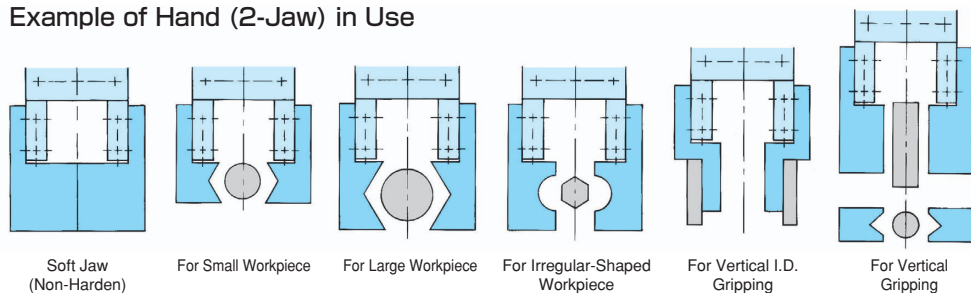

Example of Chuck (3-Jaw) in Use

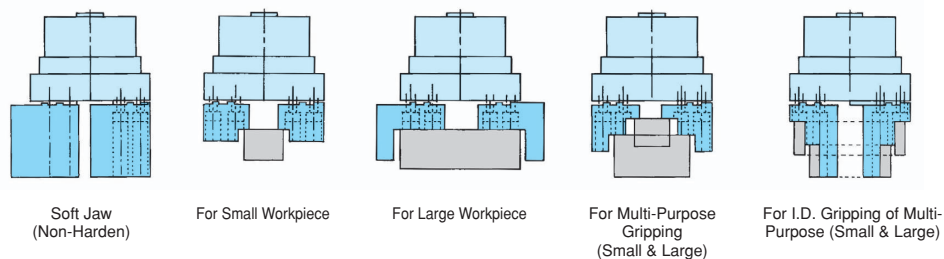

External Finger NA · NB

Layout Drawing

NA Series

External Fingers for Hand (2-Jaw)

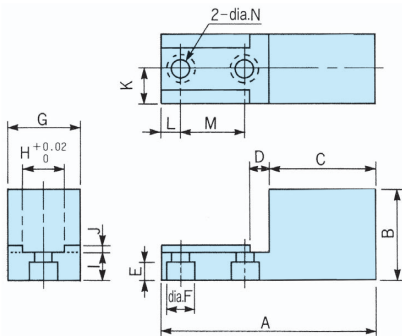

FE(S50C) & MC (Engineering Plastic)

| Supported Model | Dimensions (mm) | | | | | | | | | | | | | Weight (g) | Model Number | | |
|-----------------|-----------------|-----|------|------|------|-------|-----|---------------------------------|--------------------|----|-----|------|-----|------------|--------------|-------|-----|
| | A | B | C | D | E | dia.F | G | H ₀ ^{+0.02} | I | J | K | L | M | | | dia.N | |
| BHA-01AS | FE | 30 | 17.5 | 14.5 | 4.5 | 3 | 6 | 14 | 10 | 5 | 1.5 | 7 | 4 | 8 | 3.5 | 38 | 260 |
| BHG-01AS | MC | | | | | | | | | | | | | | | 6 | |
| BHA-03AS | FE | 40 | 21 | 21 | 5.5 | 4 | 8 | 14 | 10 | 6 | 1.5 | 7 | 4.5 | 10 | 4.5 | 61 | 270 |
| BHG-03AS | MC | | 23 | | | | | | | 8 | | | | | | 11 | |
| BHA-04AS | FE | 40 | 26.5 | 21 | 5.5 | 4 | 8 | 14 | 10 | 6 | 1.5 | 7 | 4.5 | 10 | 4.5 | 76 | 280 |
| BHG-04AS | MC | | 29.5 | | | | | | | 9 | | | | | | 12 | |
| BHA-05AS | FE | 50 | 33 | 28.5 | 6.5 | 5 | 9.5 | 14 | 10 | 8 | 2 | 7 | 6 | 10 | 5.5 | 123 | 290 |
| BHG-05AS | MC | | 39 | | | | | | | 14 | | | | | | 23 | |
| HA-1M | FE | 40 | 17 | 24.5 | 4.5 | 3 | 6 | 10 | 8 | 5 | 1.5 | 5 | 3.5 | 8 | 3.5 | 39 | 110 |
| | MC | | 21 | | | | | | | 9 | | | | | | 8 | |
| HA-2MS | FE | 50 | 26 | 28 | 5.5 | 4 | 8 | 20 | 10 | 6 | 2 | 10 | 5 | 12 | 4.5 | 135 | 120 |
| HB-2MS | MC | | 30 | | | | | | | 10 | | | | | | 25 | |
| HA-3MS | FE | 60 | 33 | 30.5 | 6.5 | 5 | 9.5 | 20 | 12 | 8 | 2 | 10 | 5.5 | 18 | 5.5 | 194 | 130 |
| HB-3MS | MC | | | | | | | | | | | | | | | 29 | |
| HA-4MS | FE | 80 | 43 | 44 | 7.5 | 6 | 11 | 20 | 14 | 10 | 2 | 10 | 8 | 20 | 6.5 | 352 | 140 |
| HB-4MS | MC | | 50 | | | | | | | 17 | | | | | | 53 | |
| HB-1M | FE | 40 | 19 | 19 | 4.5 | 3 | 6 | 12 | 8 | 5 | 1.5 | 6 | 4 | 10 | 3.5 | 44 | 150 |
| | MC | | | 21 | | | | | | 7 | | | | | | 7 | |
| HC-2MS | FE | 60 | 29 | 33 | 9.5 | 5 | 9.5 | 22 | 18 ^{+0.2} | 9 | 2 | 11 | 11 | 10 | 5.5 | 206 | 160 |
| | MC | | | | | | | | ±0.1 | | | | | | | 31 | |
| HC-3MS | FE | 70 | 35 | 34 | 11.5 | 6 | 11 | 25 | 20 ^{+0.2} | 10 | 2 | 12.5 | 8 | 20 | 6.5 | 303 | 170 |
| | MC | | | | | | | | ±0.1 | | | | | | | 45 | |
| HC-4MS | FE | 80 | 40 | 42 | 13 | 6 | 11 | 35 | 25 ^{+0.2} | 10 | 2 | 17.5 | 10 | 20 | 6.5 | 563 | 180 |
| | MC | 76 | 44 | | | | | | ±0.1 | 14 | | | 8 | | | 97 | |
| HE-2.5MS | FE | 50 | 26 | 28 | 5.5 | 4 | 8 | 20 | 10 | 6 | 2 | 10 | 5 | 12 | 4.5 | 135 | 120 |
| | MC | | 30 | | | | | | | 10 | | | | | | 25 | |
| HE-3.5MS | FE | 80 | 41 | 50 | 7.5 | 5 | 9.5 | 20 | 14 | 10 | 2 | 10 | 6 | 18 | 5.5 | 360 | 190 |
| | MC | | 49 | | | | | | | 18 | | | | | | 70 | |
| HE-4MS | FE | 120 | 60 | 81 | 11.5 | 6 | 11 | 30 | 22 | 13 | 2 | 15 | 8 | 20 | 6.5 | 1245 | 200 |
| | MC | | 77 | | | | | 32 | | 30 | | 16 | | | | 270 | |
| HE-5MS | FE | 135 | 60 | 91 | 14.5 | 8 | 14 | 30 | 28 | 16 | 2 | 15 | 10 | 25 | 8.5 | 1443 | 210 |
| | MC | | 79 | | | | | 38 | | 35 | | 19 | | | | 382 | |
| HMB-01AS | FE | 30 | 15 | 14 | 4.5 | 3 | 6 | 12 | 10 | 4 | 1.5 | 6 | 4 | 8 | 3.5 | 22 | 220 |
| | MC | | | | | | | | | | | | | | | 4 | |
| HMB-02AS | FE | 30 | 16.5 | 14 | 4.5 | 3 | 6 | 12 | 10 | 4 | 1.5 | 6 | 4 | 8 | 3.5 | 23 | 230 |
| | MC | | | | | | | | | | | | | | | 4 | |
| HK-32MS | FE | 81 | 33 | 49 | 8 | 5 | 9.5 | 22 | 16 | 13 | 2 | 11 | 6 | 18 | 5.5 | 352 | 360 |
| | MC | | 50 | | | | | 32 | | 30 | | 16 | | | | 129 | |
| HK-40MS | FE | 89 | 41 | 50 | 11 | 6 | 11 | 25 | 20 | 16 | 2 | 12.5 | 8 | 20 | 6.5 | 525 | 370 |
| | MC | | 60 | | | | | 38 | | 35 | | 19 | | | | 196 | |

External Fingers for Hand (2-Jaw)

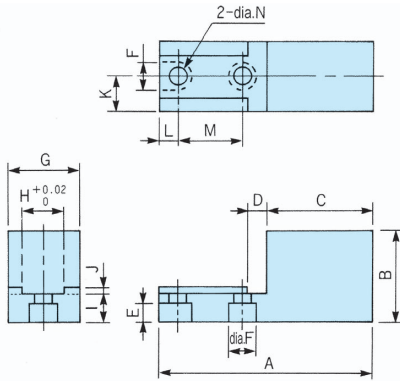

| Supported Model | Dimensions (mm) | | | | | | | | | | | | | | Weight (g) | Model Number | | |
|-----------------|-----------------|--------|------|--------------|------|-------|---|----------------------|----|----|---------|-----|---|-------|------------|--------------|-----------|-----|
| | A | B | C | D | E | dia.F | G | H ^{+0.02/0} | I | J | K | L | M | dia.N | | | | |
| HMA-01AS | F M | E C | 29.5 | 15 | 14 | 4.5 | 3 | 6 | 12 | 7 | 4 | 1.5 | 6 | 3.5 | 8 | 3.5 | 22 4 | 310 |
| HMA-02AS | F M | E C | 29.5 | 16.5 | 14 | 4.5 | 3 | 6 | 12 | 7 | 4 | 1.5 | 6 | 3.5 | 8 | 3.5 | 23 4 | 320 |
| HMA-03AS | F M | E C | 39 | 20 | 20.5 | 5.5 | 4 | 8 | 12 | 10 | 5 | 1.5 | 6 | 3.5 | 10 | 4.5 | 48 8 | 330 |
| HMA-04AS | F M | E C | 39 | 22.5 25.5 | 20.5 | 5.5 | 4 | 8 | 12 | 10 | 5 8 | 1.5 | 6 | 3.5 | 10 | 4.5 | 53 10 | 340 |
| HMA-05AS | F M | E C | 48.5 | 22.5 25.5 | 28.5 | 6.5 | 5 | 9.5 | 14 | 12 | 8 14 | 2 | 7 | 4.5 | 10 | 5.5 | 105 17 | 350 |

External Finger NA · NB

Layout Drawing

■NB Series

External Finger for Chuck (for O.D.)

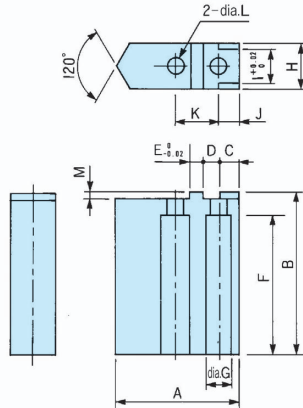

FE(S50C) & MC (Engineering Plastic)

| Supported Model | Dimensions (mm) | | | | | | | | | | | | | Weight (g) | Model Number |
|-----------------|-----------------|---|---|---|---------------------------------|---|-------|---|---------------------------------|---|---|-------|-----|------------|--------------|
| | A | B | C | D | E _{-0.02} ⁰ | F | dia.G | H | I ₀ ^{+0.02} | J | K | dia.L | M | | |
| CKA-15AS | F | E | | | | | | | | | | | | 17 | 510 |
| CKG-16AS | M | C | | | | | | | | | | | 5 | | |
| CKF-15AS | | | | | | | | | | | | | | | |
| CKA-20AS | F | E | | | | | | | | | | | 45 | 520 | |
| CKG-25AS | M | C | | | | | | | | | | | 11 | | |
| CKF-20AS | | | | | | | | | | | | | | | |
| CKA-25AS | F | E | | | | | | | | | | | 103 | 530 | |
| CKG-32AS | M | C | | | | | | | | | | | 21 | | |
| CKF-25AS | | | | | | | | | | | | | | | |
| CKA-30AS | F | E | | | | | | | | | | | 136 | 540 | |
| CKG-40AS | M | C | | | | | | | | | | | 30 | | |
| CKF-30AS | | | | | | | | | | | | | | | |

External Fingers for Chuck (for I.D.)

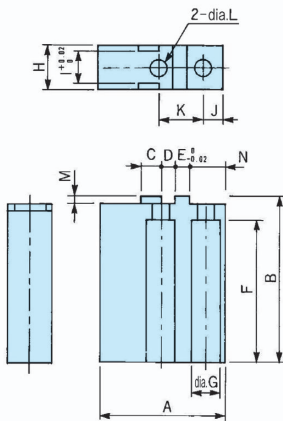

FE(S50C) & MC (Engineering Plastic)

| Supported Model | Dimensions (mm) | | | | | | | | | | | | | Weight (g) | Model Number |
|-----------------|-----------------|---|---|---|---------------------------------|---|-------|---|---------------------------------|---|---|-------|-----|------------|--------------|
| | A | B | C | D | E _{-0.02} ⁰ | F | dia.G | H | I ₀ ^{+0.02} | J | K | dia.L | M | | |
| CKA-20AS | F | E | | | | | | | | | | | | 65 | 610 |
| CKG-25AS | M | C | | | | | | | | | | | 10 | | |
| CKF-20AS | | | | | | | | | | | | | | | |
| CKA-25AS | F | E | | | | | | | | | | | 126 | 620 | |
| CKG-32AS | M | C | | | | | | | | | | | 19 | | |
| CKF-25AS | | | | | | | | | | | | | | | |
| CKA-30AS | F | E | | | | | | | | | | | 188 | 630 | |
| CKG-40AS | M | C | | | | | | | | | | | 28 | | |
| CKF-30AS | | | | | | | | | | | | | | | |

External Fingers for Chuck

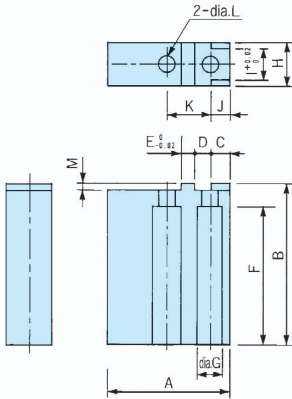

FE (S50C) & MC (Engineering Plastic)

| Supported Model | Dimensions (mm) | | | | | | | | | | | | | Weight (g) | Model Number | |
|-----------------|-----------------|------|-----|---|---------------------------------|---|-------|-----|---------------------------------|----|---|-------|-----|------------|--------------|-----|
| | A | B | C | D | E _{-0.02} ⁰ | F | dia.G | H | I ₀ ^{+0.02} | J | K | dia.L | M | | | |
| CKA-40AS | F | 44.5 | 60 | 6 | 5 | 4 | 52 | 11 | 18 | 14 | 6 | 14 | 6.5 | 2 | 285 | 710 |
| | MC | | | | | | | | | | | | | | 43 | |
| CK-1AS | F | 33.5 | 50 | 6 | 5 | 4 | 43 | 9.5 | 14 | 10 | 6 | 14 | 5.5 | 2 | 128 | 720 |
| | MC | | | | | | | | | | | | | | 19 | |
| CK-1.5AS | F | 43.5 | 65 | 7 | 6.5 | 5 | 56 | 11 | 18 | 14 | 7 | 18 | 6.5 | 2 | 302 | 730 |
| | MC | | | | | | | | | | | | | | 45 | |
| CK-2AS | F | 55.5 | 80 | 8 | 7 | 6 | 71 | 14 | 19 | 14 | 8 | 20 | 8.5 | 2 | 471 | 740 |
| | MC | | | | | | | | | | | | | | 70 | |
| CKA-50MS | F | 51.5 | 70 | 6 | 5 | 5 | 58 | 11 | 18 | 14 | 6 | 15 | 6.5 | 2 | 402 | 750 |
| | MC | | | | | | | | | | | | | | 62 | |
| CKA-60MS | F | 64 | 80 | 8 | 6 | 6 | 68 | 14 | 20 | 16 | 8 | 18 | 9 | 2 | 608 | 760 |
| | MC | | | | | | | | | | | | | | 94 | |
| CKA-70MS | F | 74 | 100 | 8 | 7 | 6 | 88 | 14 | 20 | 16 | 8 | 20 | 9 | 2 | 913 | 770 |
| | MC | | | | | | | | | | | | | | 140 | |

Accessories

External Fingers for Chuck

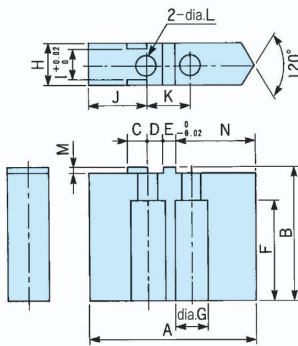

FE (S50C) & MC (Engineering Plastic)

| Supported Model | Dimensions (mm) | | | | | | | | | | | | | | Weight (g) | Model Number | |
|-----------------|-----------------|------|------|-----|---------------------------------|---|-------|-----|---------------------------------|----|------|-------|-----|-----|------------|--------------|-----|
| | A | B | C | D | E _{-0.02} ⁰ | F | dia.G | H | I ₀ ^{+0.02} | J | K | dia.L | M | N | | | |
| CKL-20AS | F | 29.5 | 29 | 3.5 | 2.5 | 2 | 23 | 6.5 | 10 | 6 | 12 | 7 | 3.5 | 1 | 13 | 64 | 810 |
| | MC | | | | | | | | | | | | | | | 10 | |
| CKL-25AS | F | 34.5 | 33.5 | 4.5 | 3.5 | 2 | 24 | 8 | 10 | 7 | 12.5 | 9 | 4.5 | 1.5 | 16.5 | 86 | 820 |
| | MC | | | | | | | | | | | | | | | 13 | |
| CKL-32AS | F | 39.5 | 33.5 | 4.5 | 3.5 | 3 | 24 | 8 | 12 | 8 | 14 | 10 | 4.5 | 1.5 | 19 | 118 | 830 |
| | MC | | | | | | | | | | | | | | | 18 | |
| CKL-40AS | F | 49.5 | 39 | 6 | 4.5 | 3 | 31 | 9 | 12 | 8 | 18.5 | 12 | 5.5 | 2 | 23.5 | 171 | 840 |
| | MC | | | | | | | | | | | | | | | 26 | |
| CKL-50AS | F | 54.5 | 44 | 6 | 5 | 4 | 33 | 11 | 14 | 10 | 18.5 | 14 | 6.5 | 2 | 27 | 250 | 850 |
| | MC | | | | | | | | | | | | | | | 37 | |
| CKL-63AS | F | 69.5 | 49 | 8 | 5.5 | 5 | 38 | 11 | 16 | 12 | 24.5 | 16 | 6.5 | 2 | 34.5 | 408 | 860 |
| | MC | | | | | | | | | | | | | | | 61 | |
| CKL-80AS | F | 84.5 | 59 | 10 | 6 | 6 | 47 | 14 | 18 | 14 | 28 | 18 | 9 | 2 | 44.5 | 676 | 870 |
| | MC | | | | | | | | | | | | | | | 101 | |
| CKL-100AS | F | 99.5 | 64 | 10 | 7 | 6 | 52 | 14 | 20 | 16 | 31.5 | 20 | 9 | 2 | 55 | 962 | 880 |
| | MC | | | | | | | | | | | | | | | 144 | |

External Finger NA · NB

Layout Drawing

■ NB Series

External Fingers for CKS series

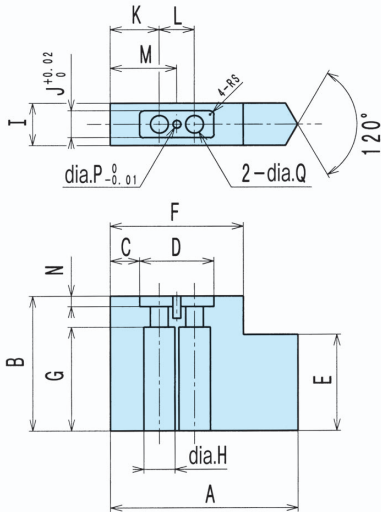

FE (S50C) & MC (Engineering Plastic)

| Supported Model | Dimensions (mm) | | | | | | | | | | | | | | Weight (g) | Model Number | | | | |
|-----------------|-----------------|------|----|-----|----|----|------|-------|-----|---------------------------------|----|------|----|------|------------|--------------------|------------------------|-------|-----------|-----|
| | A | B | C | D | E | F | G | dia.H | I | J ^{+0.02} ₀ | K | L | M | N | | | dia.P _{depth} | dia.Q | S | |
| CKS-08AS | F | 42.5 | 30 | 6.5 | 15 | 20 | 27.5 | 23 | 6.5 | 10 | 6 | 10.5 | 7 | 14 | 1.7 | dia.2 depth 4.5 | 3.5 | 1 | 74 12 | 910 |
| | MC | | | | | | | | | | | | | | | | | | 108 17 | |
| CKS-12AS | F | 48 | 35 | 7.5 | 19 | 25 | 34 | 27 | 8 | 11 | 7 | 12.5 | 9 | 17 | 2.7 | dia.2 depth 4.5 | 4.5 | 1 | 145 23 | 920 |
| | MC | | | | | | | | | | | | | | | | | | 175 17 | |
| CKS-16AS | F | 56.5 | 35 | 9.5 | 21 | 25 | 40.5 | 27 | 8 | 12 | 8 | 15 | 10 | 20 | 2.7 | dia.3 depth 4.5 | 4.5 | 1 | 145 23 | 930 |
| CKSF-16AS | MC | | | | | | | | | | | | | | | | | | 145 23 | |
| CKS-20AS | F | 66.5 | 40 | 11 | 25 | 30 | 48 | 32 | 9.5 | 12 | 8 | 17.5 | 12 | 23.5 | 2.7 | dia.3 depth 4.5 | 5.5 | 1.5 | 192 31 | 940 |
| CKSF-20AS | MC | | | | | | | | | | | | | | | | | | 192 31 | |
| CKS-25AS | F | 85.5 | 45 | 16 | 28 | 35 | 60 | 33 | 11 | 14 | 10 | 23 | 14 | 30 | 2.7 | dia.4 depth 8 | 6.5 | 1.5 | 335 53 | 950 |
| CKSF-25AS | MC | | | | | | | | | | | | | | | | | | 335 53 | |
| CKS-32AS | F | 97 | 50 | 18 | 31 | 40 | 67 | 38 | 11 | 16 | 12 | 25.5 | 16 | 33.5 | 2.7 | dia.5 depth 8 | 6.5 | 1.5 | 500 79 | 960 |
| CKSF-32AS | MC | | | | | | | | | | | | | | | | | | 500 79 | |

