

High precision type LTU-S□□CE

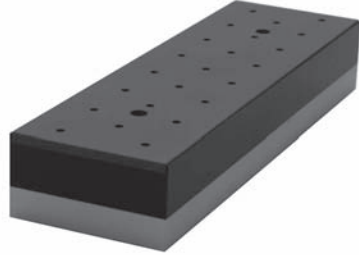

● Original design

Myotoku's air technology actualizes high precision levitating

● High precision

High process actualizes high precision (flatness · parallelism)

How to order

LTU - S 25 CE

Length

18	186mm
20	200mm
25	250mm

Specifications

Reference	Unit	LTU-S □□ CE
Size(W × L × H)	mm <inch>	76 × 186 × 40 <2.99 × 7.32 × 1.57>
		76 × 200 × 40 <2.99 × 7.87 × 1.57>
		76 × 250 × 40 <2.99 × 9.84 × 1.57>
Fluid		Non-corrosive / Non-inflammable gas *1
Ambient temperature	°C	23 ± 10
Lubrication		unavailable
Operating pressure range		Positive pressure : 30 ~ 400kPa
		Negative pressure : -5 ~ 0kPa
Flatness	μ m	10 (23°C)
Parallelism	μ m	12 (23°C)

*1 Supply compressed air using air filter with filtration rate lower than 5 μ m and oil mist separator with 0.01 μ m filtration rate.

Dimensions

Unit : mm <inch>

LTU-S□□CE

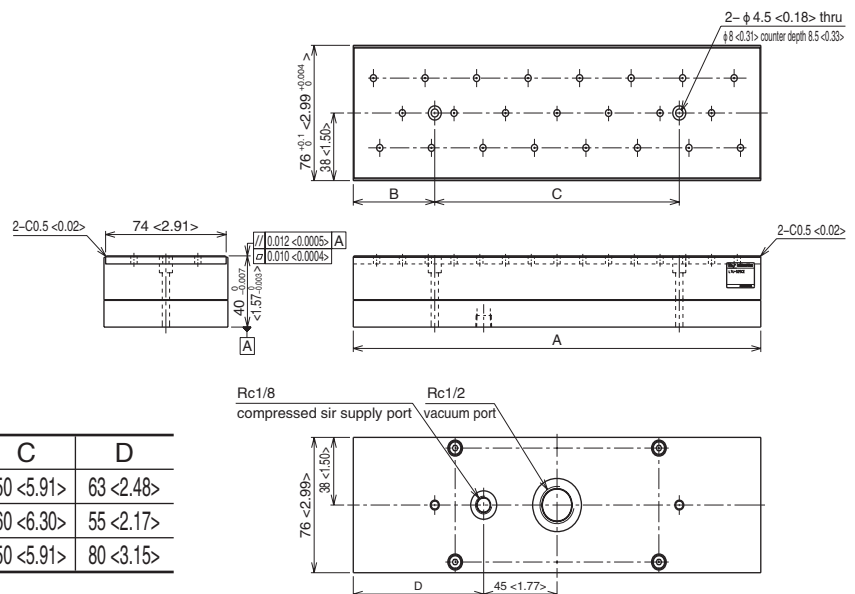

	A	B	C	D
LTU-S18CE	186 <7.32>	23 <0.91>	150 <5.91>	63 <2.48>
LTU-S20CE	200 <7.87>	20 <0.79>	160 <6.30>	55 <2.17>
LTU-S25CE	250 <9.84>	50 <1.97>	150 <5.91>	80 <3.15>