

# VCE / VCS

## EM Clutch

Types: 0.6, 1.2, 2.5, 5, 10, 20

[ EM: Electromagnet ]

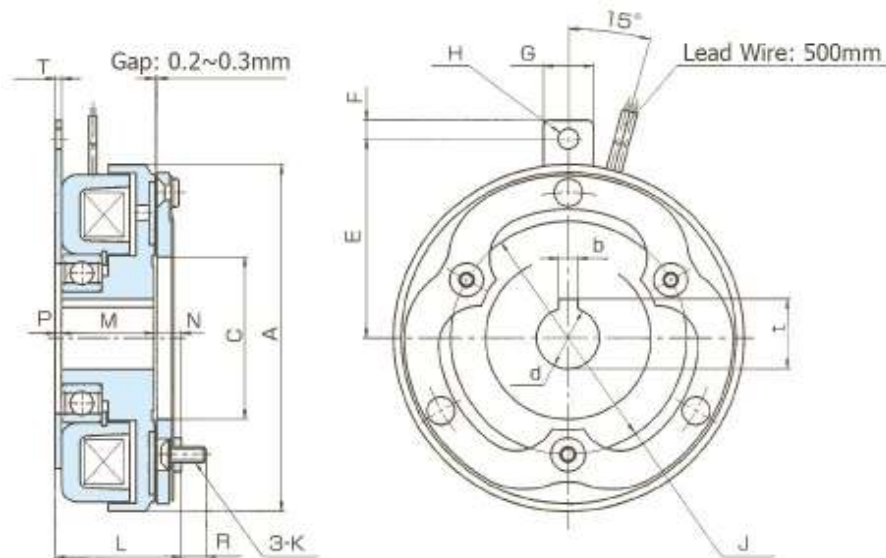

VCE / VCS Type		[ Special ] 0.6		[ Special ] 1.2		[ Special ] 2.5		[ Special ] 5		[ Special ] 10		[ Special ] 20	
		VCE	VCS <sup>1</sup>	VCE	VCS <sup>1</sup>	VCE	VCS <sup>1</sup>	VCE	VCS <sup>1</sup>	VCE	VCS <sup>1</sup>	VCE	VCS <sup>1</sup>
Static Torque [ft-lbs / N-m]		4.4 / 6		8.9 / 12		18 / 25		37 / 50		74 / 100		148 / 200	
Coil (20°C)	Voltage [DC-V]	24											
	Current [A]	0.5		0.65		0.92		1.41		1.6		2.2	
	Resistance [Ω]	48		37		26		17		15		10.9	
	Wattage [W]	12		15		22		33		38		53	
Armature	Pull-In Time [ms]	20		20		30		45		90		110	
	Release Time [ms]	20		30		50		70		85		95	
Torque Build-Up Time [ms]		50		50		70		85		130		155	
Max Allowable Speed [rpm]		7000		6000		5500		4500		3600		3000	
Moment of Inertia (J) [kg-cm <sup>2</sup> ]	Rotor	0.9	1	2.6	2.9	8.1	9.1	24.1	27	58	182		
	Armature	0.5	0.5	1.5	1.6	4.8	5.1	14.3	15.1	45	136		
Max Air Gap Until Adjustment [mm]		0.5		0.6		0.7		0.8		1.2		1.5	
Total Energy Until Adjustment [J]		2.9 x 10 <sup>7</sup>		6.6 x 10 <sup>7</sup>		13 x 10 <sup>7</sup>		26 x 10 <sup>7</sup>		62 x 10 <sup>7</sup>		120 x 10 <sup>7</sup>	
Total Energy Until Life [J]		13 x 10 <sup>7</sup>		25 x 10 <sup>7</sup>		49 x 10 <sup>7</sup>		88 x 10 <sup>7</sup>		170 x 10 <sup>7</sup>		320 x 10 <sup>7</sup>	
Bore [mm]		dh7 12		15		20		25		30		40	
Key Way [mm]	bJs9	4		5		6		8		8		12	
	t	13.8+0.15/-0		17.3+0.15/-0		22.8+0.15/-0		28.3+0.2/-0		33.3 +0.2/0		43.3 +0.2/0	
Dimensions [mm]	A	70		90		113		142		178		225	
	C	35		45		53		66		83		107	
	E	41		56		65		78		100		125	
	F	5		6		6		6		10		10	
	G	14		16		16		16		24		24	
	H	4.5		5.5		6.5		6.5		8.5		8.5	
	J	46		60		76		95		120		158	
	K	M3		M4		M5		M6		M8		M10	
	L	30	30.5	35.1	35.6	40.5	41.4	45.5	46.5	50.6	60.5		
	M	24		26.5		30		33.5		37.5		44	
	N	5.5	6	6.6	7.1	8.5	9.4	10	11	13.1	16.5		
	P	0.5		2		2		2		0		0	
	R	5.8	5.4	7	6.6	8.2	7.6	10.4	9.6	14	17.5		
	T	1.6		2		2		2		2.9		2.9	
Weight [lbs / kg]		1.2 / 0.5		2.2 / 0.1		4.2 / 1.9		7.1 / 3.2		12.8 / 5.8		23.8 / 10.8	

[ Included parts & accessories : bolts, washers, spacers, shims, surge protector ]

[ 1 inch = 25.4 mm ]

[ Note 1 : Silent type ]

# VCEH / VCSH

## EM Clutch (high torque design)

Types: 0.6, 1.2, 2.5, 5

[ EM: Electromagnet ]

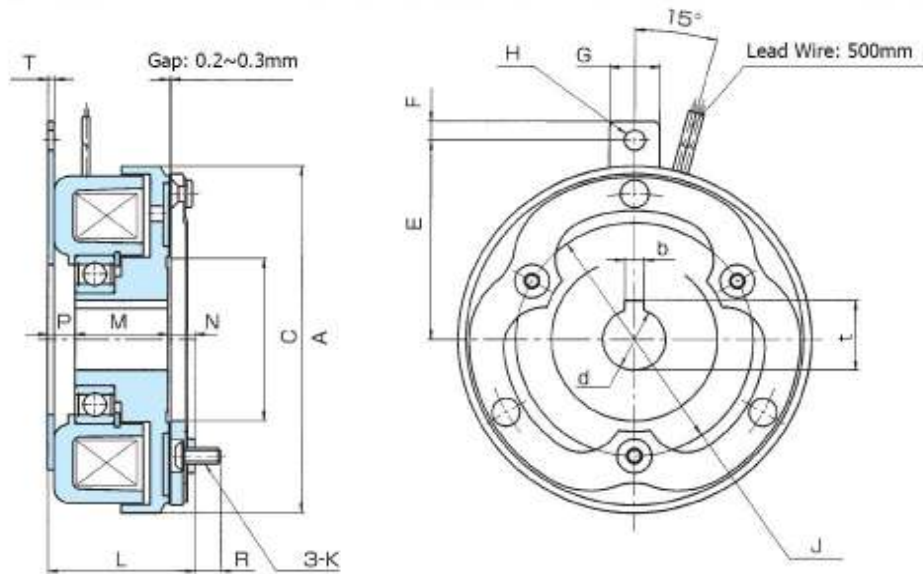

[ Special Order ]

VCEH / VCSH		0.6		1.2		2.5		5	
Type		VCEH	VCSH <sup>1</sup>	VCEH	VCSH <sup>1</sup>	VCEH	VCSH <sup>1</sup>	VCEH	VCSH <sup>1</sup>
Static Torque [ft-lbs / N-m]		5.2 / 7		11 / 15		22 / 30		44 / 60	
Coil (20°C)	Voltage [DC-V]	24							
	Current [A]	0.59		0.69		1.04		1.41	
	Resistance [Ω]	41		35		23		17	
	Wattage [W]	14		17		25		33	
Armature	Pull-In Time [ms]	15		15		25		40	
	Release Time [ms]	25		35		55		75	
Torque Build-Up Time [ms]		45		45		65		80	
Max Allowable Speed [rpm]		7000		6000		5500		4500	
Moment of Inertia (J) [kg-cm <sup>2</sup> ]	Rotor	0.9	1	2.6	2.9	8.1	9.1	24.1	27
	Armature	0.5	0.5	1.5	1.6	4.8	5.1	14.3	15.1
Max Air Gap Until Adjustment [mm]		0.5		0.6		0.7		0.8	
Total Energy Until Adjustment [J]		2.9 × 10 <sup>7</sup>		6.6 × 10 <sup>7</sup>		13 × 10 <sup>7</sup>		26 × 10 <sup>7</sup>	
Total Energy Until Life [J]		13 × 10 <sup>7</sup>		25 × 10 <sup>7</sup>		49 × 10 <sup>7</sup>		88 × 10 <sup>7</sup>	
Bore [mm]	dH7	12		15		20		25	
Key Way [mm]	bJs9	4		5		6		8	
	t	13.8+0.15/-0		17.3+0.15/-0		22.8+0.15/-0		28.3+0.2/-0	
Dimensions [mm]	A	70		90		113		142	
	C	35		45		53		66	
	E	41		56		65		78	
	F	5		6		6		6	
	G	14		16		16		16	
	H	4.5		5.5		6.5		6.5	
	J	46		60		76		95	
	K	M3		M4		M5		M6	
	L	37	37.5	41.1	41.6	47	47.9	50	51
	M	24		26.5		30		33.5	
	N	5.5	6	6.6	7.1	8.5	9.4	10	11
	P	7.5		8		8.5		6.5	
R	5.8	5.4	7	6.6	8.2	7.6	10.4	9.6	
T	1.6		2		2		2		
Weight [lbs / kg]		1.3 / 0.6		2.4 / 1.1		4.9 / 2.2		7.9 / 3.6	

[ Included parts & accessories : bolts, washers, spacers, shims, surge protector ]

[ 1 inch = 25.4 mm ]

[ Note 1 : Silent type ]

# VCEHA / VCSHA

## Self-Adjusting EM Clutch

Types: 1.2, 2.5, 5

[ EM: Electromagnet ]

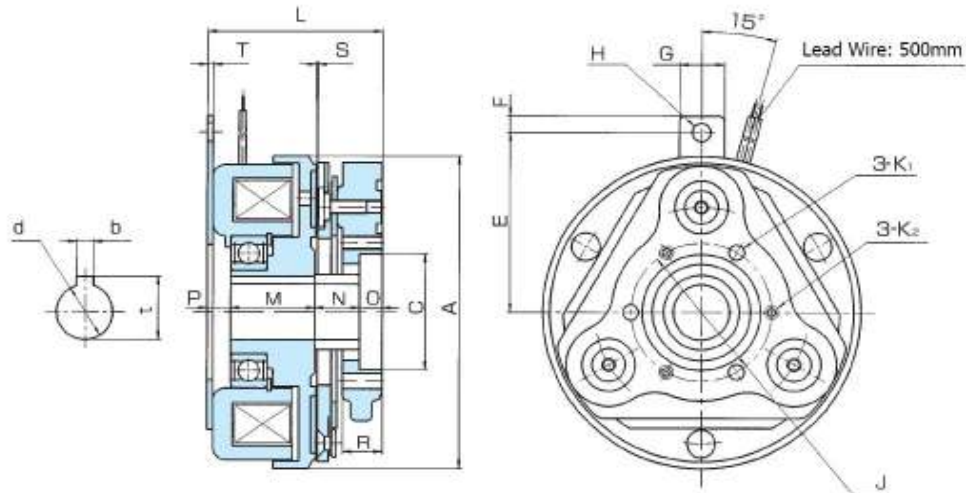

VCEHA / VCSHA		[ Special ] 1.2		[ Special ] 2.5		[ Special ] 5	
		VCEHA	VCSHA <sup>1</sup>	VCEHA	VCSHA <sup>1</sup>	VCEHA	VCSHA <sup>1</sup>
Type							
Static Torque [ft-lbs / N-m]		8.9 / 12		18 / 25		37 / 50	
Coil (20°C)	Voltage [DC-V]			24			
	Current [A]	0.69		1.04		1.41	
	Resistance [Ω]	35		23		17	
	Wattage [W]	17		25		33	
Armature	Pull-In Time [ms]	30		40		70	
	Release Time [ms]	40		60		70	
Torque Build-Up Time [ms]		60		80		120	
Max Allowable Speed [rpm]		5500		5000		4000	
Moment of Inertia (J) [kg-cm <sup>2</sup> ]	Rotor	2.6	2.9	8.1	9.1	24.1	27
	Armature	4.5	4.5	11.5	11.5	34.7	34.7
Total Energy Until Life [J]		13 x 10 <sup>7</sup>		25 x 10 <sup>7</sup>		49 x 10 <sup>7</sup>	
Bore [mm]	dH7	15		20		25	
Key Way [mm]	bJ9	5		6		8	
	t	17.3+0.15/-0		22.8+0.15/-0		28.3+0.2/-0	
	A	90		113		142	
Dimensions [mm]	CH7	32		42		52	
	E	56		65		78	
	F	6		6		6	
	G	16		16		16	
	H	5.5		6.5		6.5	
	J	40		50		62	
	K1	4.5		5.5		6.6	
	K2	M4		M5		M6	
	L	57	58	62.5	63.5	72	73
	M	26.5		30		33.5	
	N	16.5	17.5	16	17	22	23
	O	6		8		10	
	P	8		8.5		6.5	
	R	13.5		14		20	
	S	0.4		0.4		0.5	
	T	2		2		2	
Recommended Hub Bearing		6002ZZ		6004ZZ		6205ZZ	
Weight [lbs / kg]		3.1 / 1.4		5.7 / 2.6		10 / 4.5	

[ Included parts & accessories : surge protector ]

[ 1 inch = 25.4 mm ]

[ Note 1 : Silent type ]

# VCEH-P / VCSH-P

# EM Clutch (one piece high torque design)

Types: 1.2, 2.5, 5

[ EM: Electromagnet ]

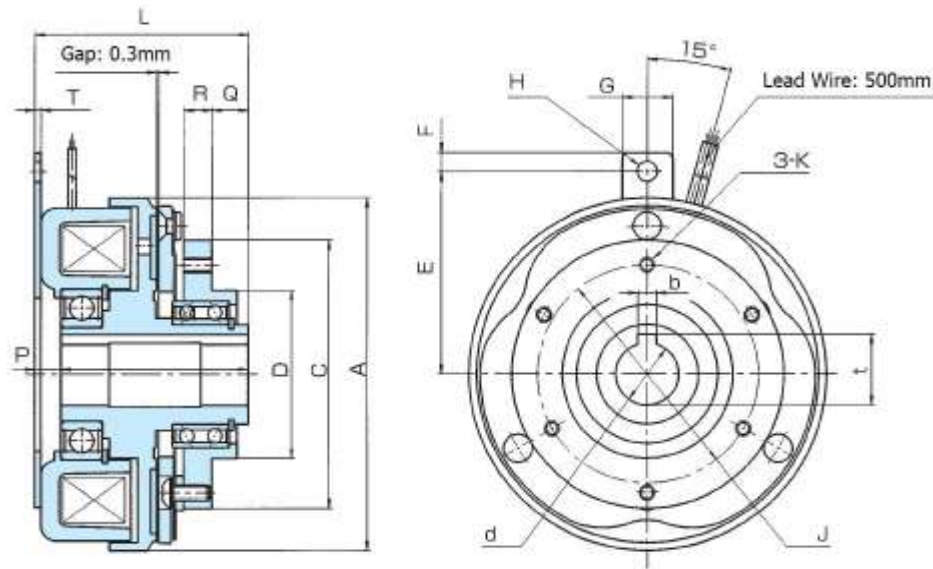

[ Special Order ]

VCEH-P / VCSH-P		1.2P		2.5P		5P	
Type		VCEH	VCSH <sup>1</sup>	VCEH	VCSH <sup>1</sup>	VCEH	VCSH <sup>1</sup>
Static Torque [ft-lbs / N-m]		11 / 15		22 / 30		44 / 60	
Coil (20°C)	Voltage [DC-V]	24					
	Current [A]	0.69		1.04		1.41	
	Resistance [Ω]	35		23		17	
	Wattage [W]	17		25		33	
Armature	Pull-In Time [ms]	15		25		40	
	Release Time [ms]	35		55		75	
Torque Build-Up Time [ms]		45		65		80	
Max Allowable Speed [rpm]		6000		5500		4500	
Moment of Inertia (J) [kg-cm <sup>2</sup> ]	Rotor	3	3.3	8.4	9.4	25.4	28.2
	Armature	3.8	3.9	8.6	9	26	26.8
Total Energy Until Life [J]		13 x 10 <sup>7</sup>		25 x 10 <sup>7</sup>		49 x 10 <sup>7</sup>	
Bore [mm]	dH7	15		20		25	
Key Way [mm]	bJs9	5		6		8	
	t	17.3+0.15/-0		22.8+0.15/-0		28.3+0.2/-0	
Dimensions [mm]	A	90		113		142	
	Ch8	76		86		106	
	Dh8	54		54		72	
	E	56		65		78	
	F	6		6		6	
	G	16		16		16	
	H	5.5		6.5		6.5	
	J	66		70		90	
	K	M4		M5		M6	
	L	64		67.5		76.5	
	M	56		59		70	
	P	8		8.5		6.5	
	Q	15	14.5	11.5	10.6	15.5	14.5
R	7.9		9		11		
T	2		2		2		
Weight [lbs / kg]		3.7 / 1.7		6.2 / 2.8		11 / 5	

[ Included parts & accessories : surge protector ]

[ 1 inch = 25.4 mm ]

[ Note 1 : Silent type ]

# VC: TYPICAL INSTALLATION

## Standard Type

Armature mounting  
Use included bolts and spacers  
Prevent loosening of bolts

Mounting surface perpendicularity  
MAX 0.1mm TIR

Pulley  
Customer Supplied

Shaft  
Eliminate axial play

Use 2 ball bearings  
Avoid impact/shock  
Customer Supplied

Gap:  $0.2 \sim 0.3 \text{mm} \pm 20\%$

Antirotation  
Allow axial movement

Ball bearing  
Avoid impact/shock

Shaft tolerance  
h6 or js6 (JIS B0401)

Gap adjustment  
Use collar and shims

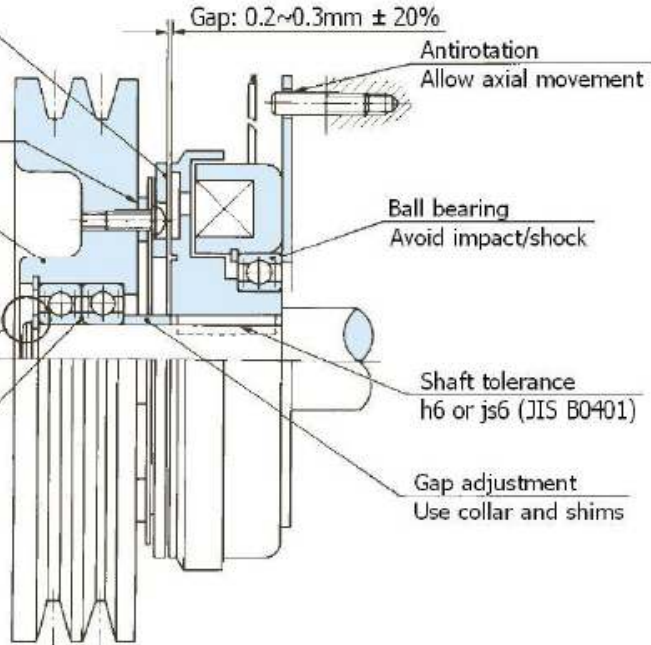

## Auto Adjust Type (output bearings and pulley or sprocket supplied by customer)

Bolts  
Prevent loosening

Mounting surface perpendicularity  
MAX 0.1mm TIR

Bearing fit  
Depth tolerance:  $+0.05 \text{mm}$   
 $0$

Use 2 ball bearings  
Avoid impact/shock  
Customer supplied

Gap adjustment  
Use collar and shims

Gap: S

Antirotation  
Allow movement

Ball bearing  
Avoid impact/shock

Shaft  
Eliminate axial play

Shaft tolerance  
h5 or js6 (JIS B0401)

Armature/hub assembly  
Avoid impact/shock

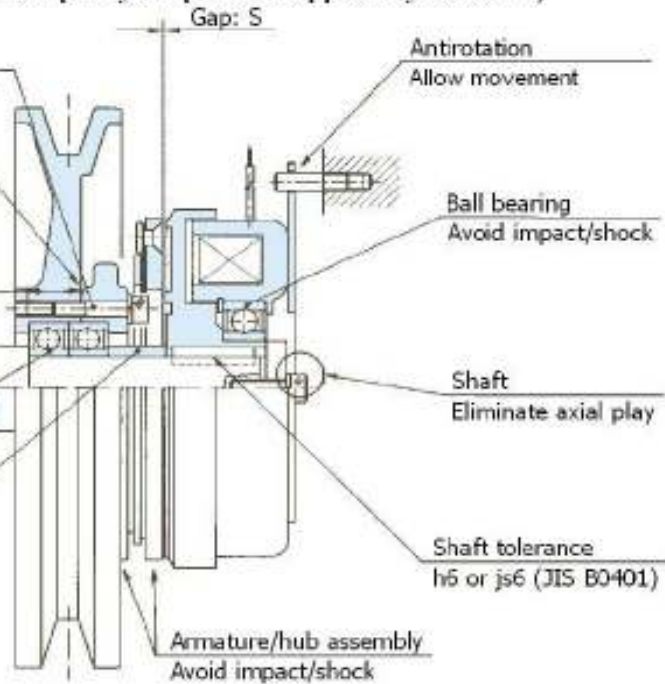

# VC: TYPICAL INSTALLATION

## One Piece Type

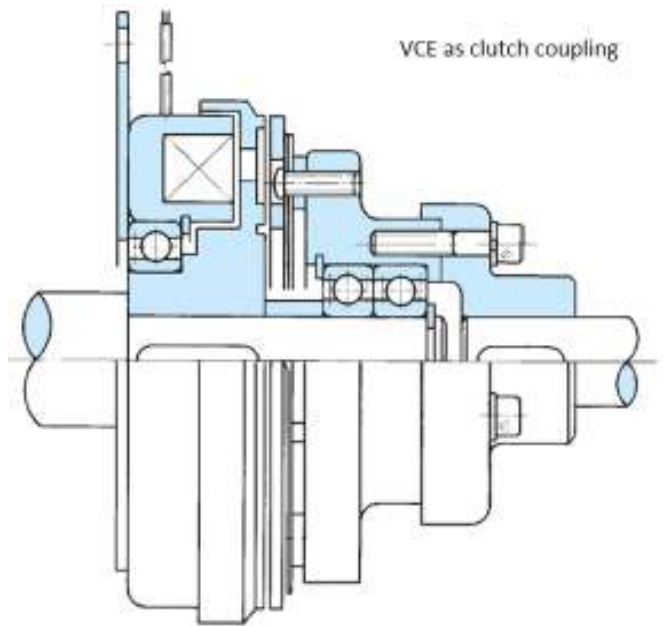
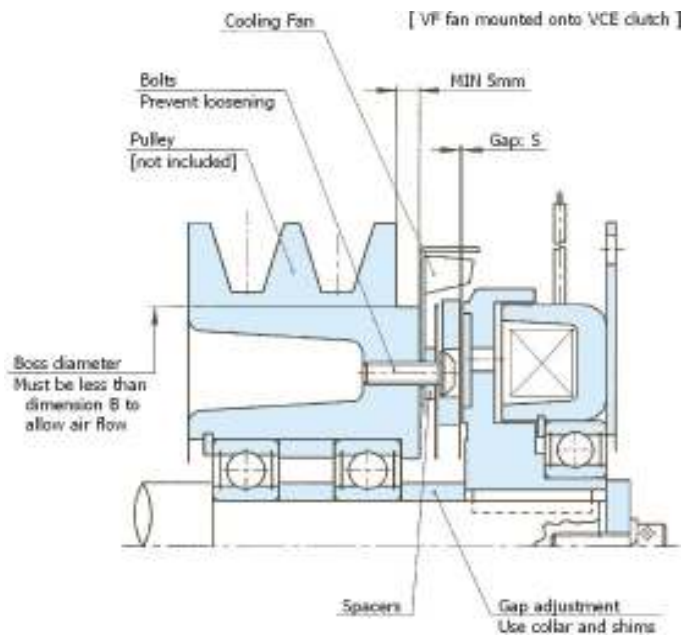
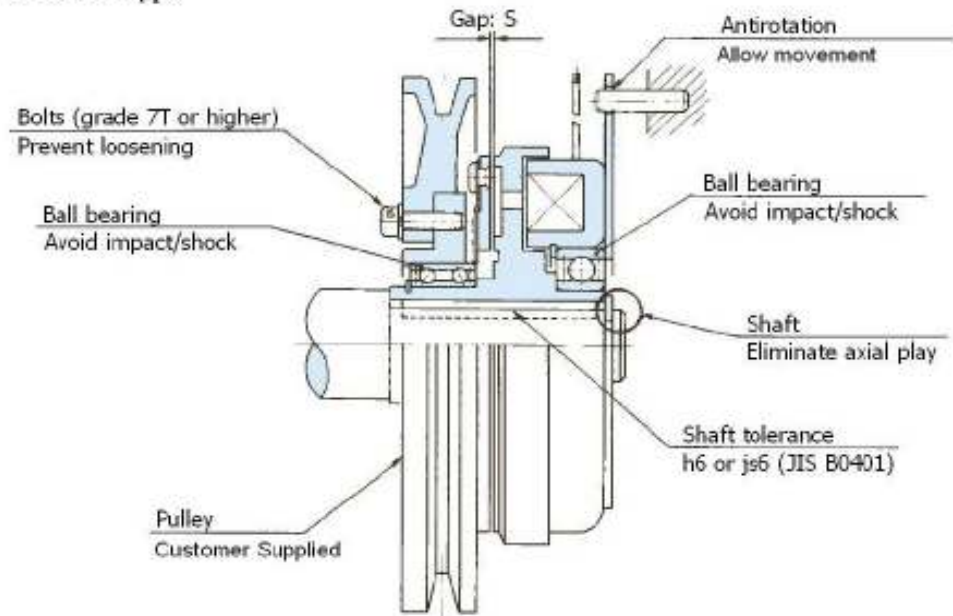



# VC: TORQUE CHARACTERISTIC & MAX WORK RATE

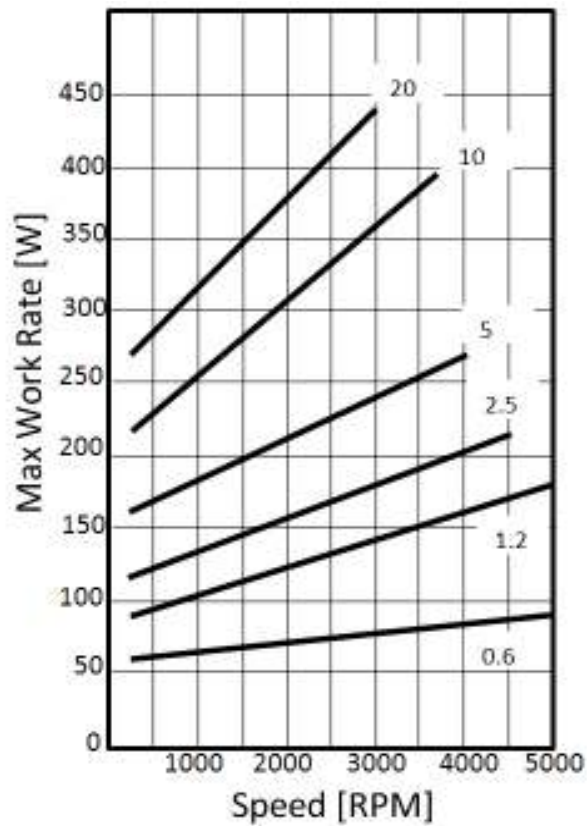
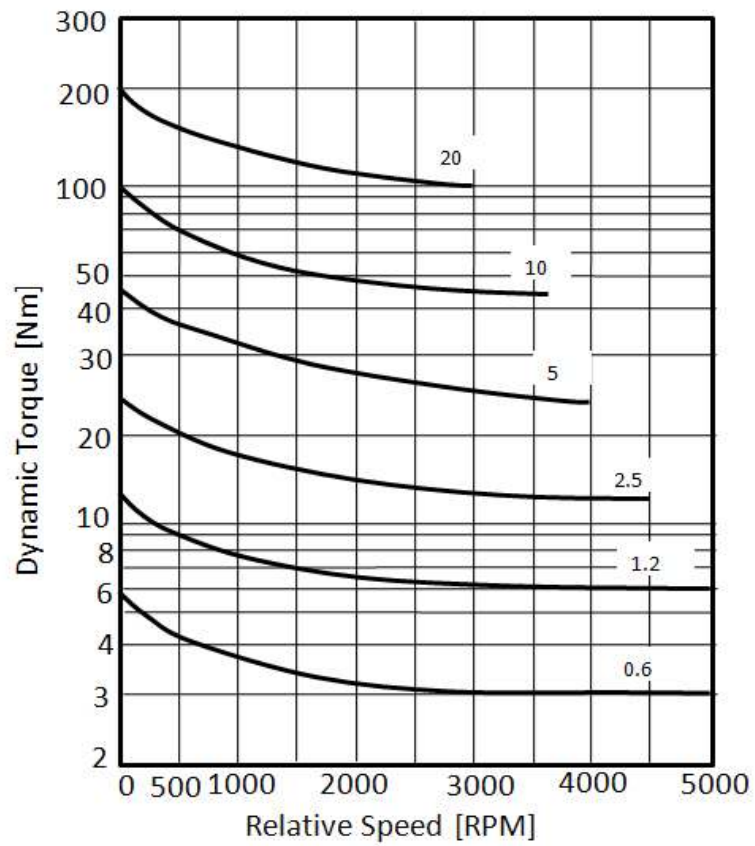

# VF

## Cooling Fan for V-Series Units

Types: 1.2, 2.5, 5

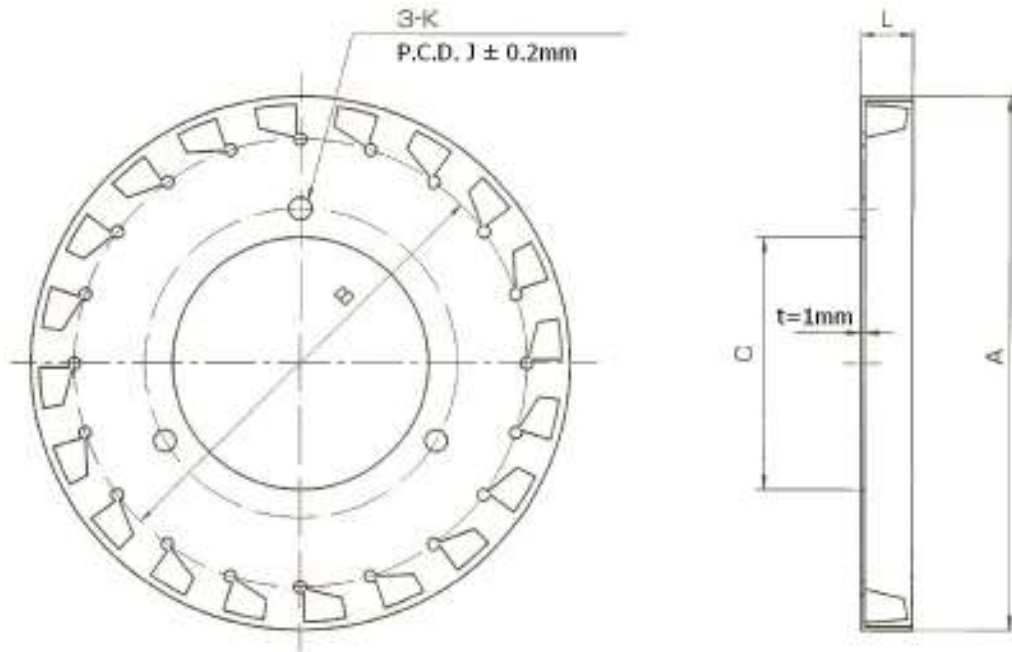

VF		1.2	2.5	5	
Max Allowable Speed [rpm]		2000	2000	2000	
Dimensions [mm]	A	108	131	164	
	B	88	110	138	
	C	50	62	76	
	K	4.5	5.5	6.5	
	J	60	76	95	
	L	11	13	16	
Applicable Units		VCE(H)	VCS(H)	VBE(H)	VBS(H)
Optional Units <sup>1</sup>		VCE(H)-P	VCS(H)-P	VCEHA	VCSHA
		VBE(H)-P	VBS(H)-P	VBEHA	VBSHA

[ Note 1 : Available as factory-mounted only ]

[ 1 inch = 25.4 mm ]