

# Merkur<sup>®</sup> ES Spray Packages

3A0732N  
EN

For low-volume fine finish spray applications. For professional use only.



## Important Safety Instructions

Read all warnings and instructions in this manual. Save these instructions.

### 15:1 Spray Packages

### 30:1 Spray Packages

*100 psi (0.7 MPa, 7.0 bar) Maximum Air Inlet Pressure*

See page 3 for model information, including maximum fluid working pressure.

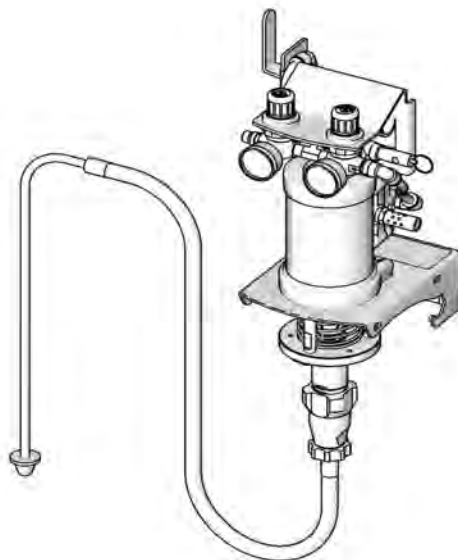

ti15589a

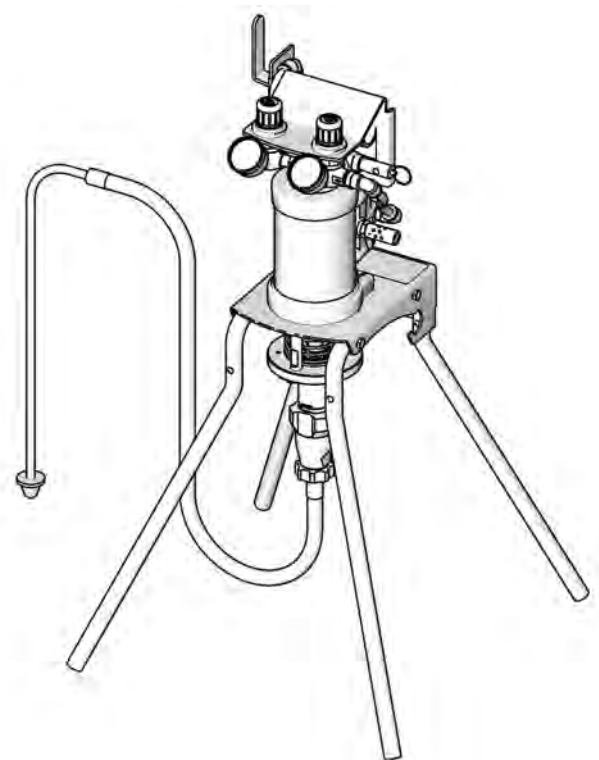

ti15590a



II 2 G c T5 X

# Contents

<b>Models</b> .....	<b>3</b>	<b>Package Weights</b> .....	<b>39</b>
<b>Warnings</b> .....	<b>4</b>	<b>Wall Bracket Mounting Hole Diagram</b> .....	<b>40</b>
<b>Installation</b> .....	<b>7</b>	<b>Technical Data</b> .....	<b>41</b>
Prepare the Operator .....	7	<b>Performance Charts</b> .....	<b>42</b>
Prepare the Site .....	7	15:1 Ratio Pumps .....	42
Supplied Components .....	7	30:1 Ratio Pumps .....	43
Inline Fluid Filter Kits .....	7	<b>Graco Standard Warranty</b> .....	<b>44</b>
Air Line Accessories .....	7	<b>Graco Information</b> .....	<b>44</b>
Wall Mount Packages .....	8		
Grounding .....	8		
Flush Before Using Equipment .....	8		
Setup .....	9		
<b>Operation</b> .....	<b>10</b>		
Pressure Relief Procedure .....	10		
Trigger Lock .....	10		
Prime the Pump .....	10		
Install the Spray Tip .....	11		
Adjust the Atomization .....	11		
Adjust the Spray Pattern .....	12		
Shutdown .....	12		
<b>Maintenance</b> .....	<b>13</b>		
Tighten Threaded Connections .....	13		
Flush the Pump .....	13		
<b>Troubleshooting</b> .....	<b>14</b>		
<b>Repair</b> .....	<b>15</b>		
General Information .....	15		
To Remove Intake Valve Only .....	15		
Disconnect the Displacement Pump .....	15		
Disassemble the Pump .....	16		
Reassemble the Pump .....	16		
Reconnect the Displacement Pump .....	16		
Repair Air Valve .....	18		
Replace Pilot Valves .....	20		
Disconnect the Air Motor .....	21		
Reconnect the Air Motor .....	21		
Repair Air Motor .....	22		
<b>Parts</b> .....	<b>25</b>		
Package Parts .....	25		
Hose and Gun .....	29		
Displacement Pump Parts .....	30		
Air Motor Parts .....	32		
Air Valve Parts .....	34		
Air Control Parts .....	36		
<b>Kits and Accessories</b> .....	<b>38</b>		
<b>Package Dimensions</b> .....	<b>39</b>		





# Models

Package	Series	Ratio	Maximum Fluid Working Pressure psi (MPa, bar)	Package Type	Gun	Mounting	Material
24F150	A	15:1	1500 (10.3, 103)	Air-assisted	G15 Carbide	Wall	Plated Steel
24F151	A	15:1	1500 (10.3, 103)	Air-assisted	G15 Carbide	Stand	Plated Steel
24F152	A	30:1	3000 (20.7, 207)	Air-assisted	G40	Wall	Stainless Steel
24F153	A	30:1	3000 (20.7, 207)	Air-assisted	G40	Stand	Stainless Steel
24F154	A	30:1	3000 (20.7, 207)	Airless	Silver Plus	Wall	Plated Steel
24F155	A	30:1	3000 (20.7, 207)	Airless	Silver Plus	Stand	Plated Steel
24F156	A	30:1	3000 (20.7, 207)	Air-assisted	G40	Wall	Plated Steel
24F157	A	30:1	3000 (20.7, 207)	Air-assisted	G40	Stand	Plated Steel
24F158	A	15:1	1500 (10.3, 103)	Air-assisted	G15 Carbide	Wall	Stainless Steel
24F159	A	15:1	1500 (10.3, 103)	Air-assisted	G15 Carbide	Stand	Stainless Steel
24N548*	A	30:1	3000 (20.7, 207)	WB3000	-----	-----	Stainless Steel
24W281	A	15:1	1500 (10.3, 103)	Air-assisted	G15 Carbide	Stand	Plated Steel
24W283	A	15:1	1500 (10.3, 103)	Air-assisted	G15 Carbide	Stand	Stainless Steel
24W285	A	30:1	3000 (20.7, 207)	Air-assisted	G40	Stand	Plated Steel
24W287	A	30:1	3000 (20.7, 207)	Air-assisted	G40	Stand	Stainless Steel
24X311*	A	15:1	1500 (10.3, 103)	Air-assisted	-----	Wall	Plated Steel







- \* Part No. 24N548 is used as a supply pump in the WB3000 Waterborne Isolation System. It includes a pump bracket and items 7-19, 21, 23, and 28-42 on page 25. See manual 3A2497 for warnings and instructions for a waterborne system.
- \* Part No. 24X311 is used as a solvent flush pump in the M2K system. See manual 333309 for warnings and instructions for a solvent flush pump.

# Warnings

The following warnings are for the setup, use, grounding, maintenance, and repair of this equipment. The exclamation point symbol alerts you to a general warning and the hazard symbols refer to procedure-specific risks. When these symbols appear in the body of this manual, refer back to these Warnings. Product-specific hazard symbols and warnings not covered in this section may appear throughout the body of this manual where applicable.

 <b>WARNING</b>	
	<p><b>FIRE AND EXPLOSION HAZARD</b></p> <p>Flammable fumes, such as solvent and paint fumes, in <b>work area</b> can ignite or explode. To help prevent fire and explosion:</p> <ul style="list-style-type: none"> <li>• Use equipment only in well ventilated area.</li> <li>• Eliminate all ignition sources; such as pilot lights, cigarettes, portable electric lamps, and plastic drop cloths (potential static arc).</li> <li>• Keep work area free of debris, including solvent, rags and gasoline.</li> <li>• Do not plug or unplug power cords, or turn power or light switches on or off when flammable fumes are present.</li> <li>• Ground all equipment in the work area. See <b>Grounding</b> instructions.</li> <li>• Use only grounded hoses.</li> <li>• Hold gun firmly to side of grounded pail when triggering into pail.</li> <li>• If there is static sparking or you feel a shock, <b>stop operation immediately</b>. Do not use equipment until you identify and correct the problem.</li> <li>• Keep a working fire extinguisher in the work area.</li> </ul>
	<p><b>SPECIAL CONDITIONS FOR SAFE USE</b></p> <p>Static charge may build up on plastic parts during cleaning and could discharge and ignite flammable vapors. To help prevent fire and explosion:</p> <ul style="list-style-type: none"> <li>• Clean plastic parts only in well ventilated area.</li> <li>• Do not clean with a dry cloth.</li> <li>• Do not operate electrostatic guns in equipment work area.</li> </ul>
	<p><b>SKIN INJECTION HAZARD</b></p> <p>High-pressure fluid from gun, hose leaks, or ruptured components will pierce skin. This may look like just a cut, but it is a serious injury that can result in amputation. <b>Get immediate surgical treatment.</b></p> <ul style="list-style-type: none"> <li>• Do not spray without tip guard and trigger guard installed.</li> <li>• Engage trigger lock when not spraying.</li> <li>• Do not point gun at anyone or at any part of the body.</li> <li>• Do not put your hand over the spray tip.</li> <li>• Do not stop or deflect leaks with your hand, body, glove, or rag.</li> <li>• Follow the <b>Pressure Relief Procedure</b> when you stop spraying and before cleaning, checking, or servicing equipment.</li> <li>• Tighten all fluid connections before operating the equipment.</li> <li>• Check hoses and couplings daily. Replace worn or damaged parts immediately.</li> </ul>

# ! WARNING

 	<p><b>EQUIPMENT MISUSE HAZARD</b></p> <p>Misuse can cause death or serious injury.</p> <ul style="list-style-type: none"> <li>• Do not operate the unit when fatigued or under the influence of drugs or alcohol.</li> <li>• Do not exceed the maximum working pressure or temperature rating of the lowest rated system component. See <b>Technical Data</b> in all equipment manuals.</li> <li>• Use fluids and solvents that are compatible with equipment wetted parts. See <b>Technical Data</b> in all equipment manuals. Read fluid and solvent manufacturer's warnings. For complete information about your material, request MSDS from distributor or retailer.</li> <li>• Do not leave the work area while equipment is energized or under pressure. Turn off all equipment and follow the <b>Pressure Relief Procedure</b> when equipment is not in use.</li> <li>• Check equipment daily. Repair or replace worn or damaged parts immediately with genuine manufacturer's replacement parts only.</li> <li>• Do not alter or modify equipment.</li> <li>• Use equipment only for its intended purpose. Call your distributor for information.</li> <li>• Route hoses and cables away from traffic areas, sharp edges, moving parts, and hot surfaces.</li> <li>• Do not kink or over bend hoses or use hoses to pull equipment.</li> <li>• Keep children and animals away from work area.</li> <li>• Comply with all applicable safety regulations.</li> </ul>
 	<p><b>MOVING PARTS HAZARD</b></p> <p>Moving parts can pinch, cut or amputate fingers and other body parts.</p> <ul style="list-style-type: none"> <li>• Keep clear of moving parts.</li> <li>• Do not operate equipment with protective guards or covers removed.</li> <li>• Pressurized equipment can start without warning. Before checking, moving, or servicing equipment, follow the <b>Pressure Relief Procedure</b> and disconnect all power sources.</li> </ul>
 	<p><b>TOXIC FLUID OR FUMES HAZARD</b></p> <p>Toxic fluids or fumes can cause serious injury or death if splashed in the eyes or on skin, inhaled, or swallowed.</p> <ul style="list-style-type: none"> <li>• Read MSDSs to know the specific hazards of the fluids you are using.</li> <li>• Store hazardous fluid in approved containers, and dispose of it according to applicable guidelines.</li> </ul>
	<p><b>PERSONAL PROTECTIVE EQUIPMENT</b></p> <p>You must wear appropriate protective equipment when operating, servicing, or when in the operating area of the equipment to help protect you from serious injury, including eye injury, hearing loss, inhalation of toxic fumes, and burns. This equipment includes but is not limited to:</p> <ul style="list-style-type: none"> <li>• Protective eyewear, and hearing protection.</li> <li>• Respirators, protective clothing, and gloves as recommended by the fluid and solvent manufacturer.</li> </ul>



# Installation

## Prepare the Operator

All persons who operate the equipment must be trained in the safe, efficient operation of all system components as well as the proper handling of all fluids. All operators must thoroughly read all instruction manuals, tags, and labels before operating the equipment.

## Prepare the Site

Ensure that you have an adequate compressed air supply.

Bring a compressed air supply line from the air compressor to the pump location. Be sure all air hoses are properly sized and pressure-rated for your system. Use only electrically conductive hoses. The air hose should have a 3/8 npt(m) thread. A quick disconnect coupling is recommended.

Keep the site clear of any obstacles or debris that could interfere with the operator's movement.

Have a grounded, metal pail available for use when flushing the system.

## Supplied Components

See FIG. 2 on page 9.

- The **red-handled bleed-type master air valve (D)** is required in your system to relieve air trapped between it and the air motor and gun when the valve is closed. Do not block access to the valve.
- The **pump air regulator (F)** controls pump speed and outlet pressure by adjusting the air pressure to the pump.
- The **air pressure relief valve (P)** opens automatically to prevent overpressurization of the pump.
- The **gun air regulator (E)** adjusts the air pressure to the air-assisted spray gun.
- The **spray gun (H)** dispenses the fluid. The gun houses the spray tip (not shown), which is available in a wide range of sizes for different spray patterns and rates of flow. Refer to gun manual for tip installation.
- The **red hose (G)** provides the gun air supply.
- The **blue hose (K)** provides the gun fluid supply.
- The **suction kit with strainer (J)** allows the pump to draw fluid from a 5 gallon (19 liter) pail.

## Inline Fluid Filter Kits

Inline fluid filter kits are available as an accessory in stainless steel (24F271) or aluminum (24F272), to filter particles from fluid as it leaves the pump. Kits include a 60 mesh (250 micron) stainless steel element.

## Air Line Accessories

Install the following accessories in the order shown in FIG. 2, using adapters as necessary.



- An **air-line filter (C)** removes harmful dirt and moisture from the compressed air supply.
- A second **bleed-type air shutoff valve (B)** isolates the air line accessories for servicing. Locate upstream from all other air line accessories.

## Wall Mount Packages

1. Be sure the wall can support the weight of the pump, bracket, hoses and accessories, as well as the stress caused during operation.
2. Position the wall bracket at a convenient height. Do not stretch the suction hose tight; let it hang to assist fluid flow into the pump. For ease of operation and service, make sure the pump air inlet, fluid inlet, and fluid outlet ports are easily accessible.
3. Using the wall bracket as a template, drill mounting holes in the wall. Hole diameters and wall mounting dimensions are shown on page 40.
4. Attach the bracket to the wall. Use screws that are long enough to keep the pump from vibrating during operation.

**NOTE:** Be sure the bracket is level.

## Grounding

						
<p>The equipment must be grounded. Grounding reduces the risk of static and electric shock by providing an escape wire for the electrical current due to static build up or in the event of a short circuit.</p>						

1. **Pump:** See FIG. 1. Verify that the ground wire (26) is attached to the ground screw (23), and the screw is tightened securely to the adapter plate (10). Use any of the three threaded holes in the adapter plate. Connect the other end of the ground wire to a true earth ground.

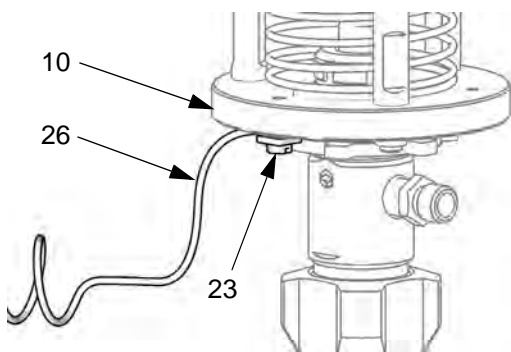

ti16282a

**FIG. 1. Ground Wire**

2. **Air and fluid hoses:** Static electricity may build up when fluids flow through pumps, hoses, and sprayers. At least one hose must be electrically conductive, with a maximum of 500 ft. (150 m) combined hose length to ensure grounding continuity. Check electrical resistance of hoses. If total resistance to ground exceeds 25 megohms, replace hose immediately.
3. **Air compressor:** follow manufacturer's recommendations.
4. **Spray gun:** ground through connection to a properly grounded fluid hose and pump.
5. **Fluid supply container:** follow your local code.
6. **Object being sprayed:** follow your local code.
7. **Solvent pails used when flushing:** follow your local code. Use only metal pails, which are conductive, placed on a grounded surface. Do not place the pail on a nonconductive surface, such as paper or cardboard, which interrupts the grounding continuity.
8. To maintain grounding continuity when flushing or relieving pressure, hold a metal part of the spray gun firmly to the side of a grounded metal pail, then trigger the gun.

## Flush Before Using Equipment

The equipment was tested with lightweight oil, which is left in the fluid passages to protect parts. To avoid contaminating your fluid with oil, flush the equipment with a compatible solvent before using the equipment. See **Prime the Pump**, page 10.



## Setup

1. See FIG. 2. Attach one end of fluid hose (K) to pump outlet (or optional inline fluid filter outlet).
2. Attach other end of fluid hose to gun fluid inlet at base of gun (H).
3. Attach one end of the air hose (G) to gun air regulator (E).
4. Attach remaining end of the air hose to air inlet at base of gun (H).
5. Clip fluid and air hoses together with the supplied hose clips (qty. of 7). Space clips as needed.
6. Attach the fluid suction kit (J) to the pump inlet.

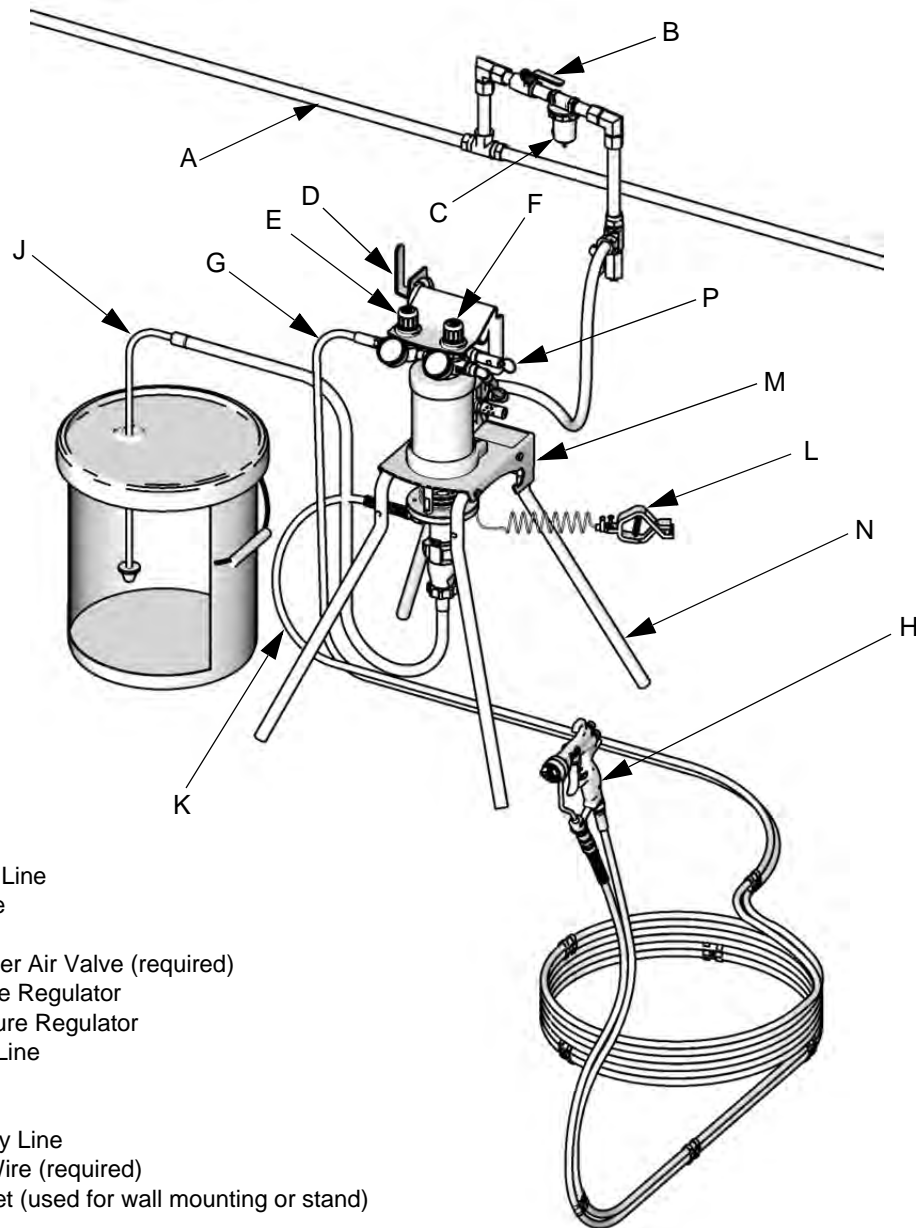

### Key:

- A Main Air Supply Line
- B Air Shutoff Valve
- C Air Filter
- D Bleed-type Master Air Valve (required)
- E Gun Air Pressure Regulator
- F Pump Air Pressure Regulator
- G Gun Air Supply Line
- H Spray Gun
- J Fluid Suction Kit
- K Gun Fluid Supply Line
- L Pump Ground Wire (required)
- M Mounting Bracket (used for wall mounting or stand)
- N Pump Stand
- P Air Pressure Relief Valve

ti15591a

**FIG. 2. Typical Installation (Air-Assisted Stand Mount Package Shown)**

# Operation

## Pressure Relief Procedure



Trapped air can cause the pump to cycle unexpectedly, which could result in serious injury from skin injection, splashing or moving parts.

1. Lock the gun trigger.
2. See FIG. 2. Turn off the bleed-type master air valve (D).
3. Unlock the gun trigger.
4. Hold a metal part of the gun firmly to a grounded metal waste container. Trigger the gun to relieve fluid pressure.
5. Lock the gun trigger.
6. If you suspect that pressure has not been fully relieved after following the steps above, check the following:
  - a. The spray tip may be completely clogged. Very slowly loosen the air cap retaining ring to relieve pressure in the cavity between the ball/seat shutoff and the plugged tip. Clear the tip orifice.
  - b. The gun fluid filter or the fluid hose may be completely clogged. Very slowly loosen the hose end coupling at the gun and relieve pressure gradually. Then loosen completely to clear the obstruction.
  - c. After following the steps above, if the spray tip or hose still seems completely clogged, very slowly loosen the tip guard retaining nut or hose end coupling and relieve pressure gradually, then loosen completely. With tip removed, trigger gun into waste container.

## Trigger Lock



See FIG. 3. Always engage gun trigger lock when you stop spraying to prevent gun from being triggered accidentally by hand or if dropped or bumped.

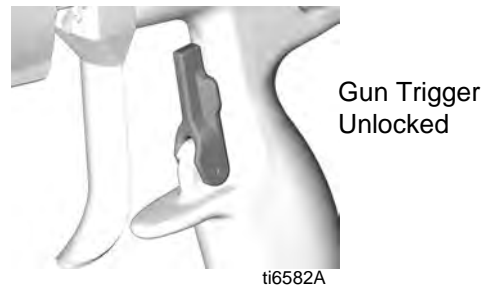
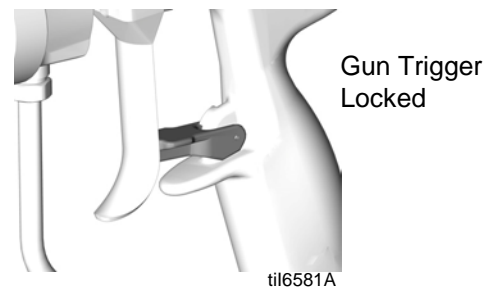
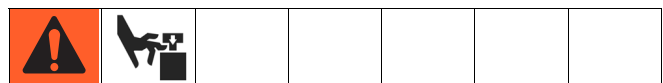

FIG. 3. Trigger Lock

## Prime the Pump



Have safety spring (9) in place during operation to reduce risk of pinching or loss of fingers.

1. See FIG. 3. Lock gun trigger. Remove tip guard and spray tip from gun. Refer to gun manual.

2. See FIG. 2. Close gun air regulator (E) and pump air regulator (F) by turning knobs counterclockwise reducing pressure to zero. Close bleed-type air valve (D).
3. Connect air line to bleed type air valve.
4. Check that all fittings throughout system are tightened securely.
5. Position pail close to pump. Suction hose is 3 ft (0.9 m) long. Do not stretch hose tight; let it hang to assist fluid flow into pump.
6. Hold metal part of gun firmly to side of grounded metal pail, unlock trigger, and hold trigger open.
7. Open bleed-type air valve. Slowly turn pump air regulator clockwise, increasing pressure until pump starts.
8. Cycle pump slowly until all air is pushed out and pump and hoses are fully primed.
9. Release gun trigger and lock trigger safety. Pump should stall against pressure.

## Install the Spray Tip



Follow **Pressure Relief Procedure**, page 10. Install the spray tip and tip guard as explained in your separate gun manual, supplied.

The fluid output and pattern width depend on the size of the spray tip, the fluid viscosity, and the fluid pressure. Use the Spray Tip Selection Chart in your gun instruction manual as a guide for selecting an appropriate spray tip for your application.

**NOTE:** The maximum recommended spray tip size is .019 in. (0.483 mm).

## Adjust the Atomization



**NOTE:** Use this procedure with airless and air-assisted spray guns.

1. Do not turn on atomizing air supply. Fluid pressure is controlled by the air pressure supplied to the pump (pump air regulator). Set fluid pressure at low starting pressure. For low viscosity fluids (less than 25 sec, #2 Zahn cup) with lower percent solids (typically less than 40%), start at 300 psi (2.1 MPa, 21 bar) at pump outlet. For fluids with higher viscosity or higher solids content, start at 600 psi (4.2 MPa, 42 bar). Refer to the following example.

**Example:**

Pump Ratio		Pump Air Regulator Setting psi (MPa, bar)	=	Approximate Fluid Pressure psig (MPa, bar)
15:1	x	20 (0.14, 1.4)	=	300 (2.1, 21)
30:1	x	20 (0.14, 1.4)	=	600 (4.2, 42)

2. Hold gun perpendicular and approximately 12 inches (304 mm) from surface.
3. Move gun first, then pull gun trigger to spray onto test paper.
4. Increase fluid pressure in 100 psi (0.7 MPa, 7 bar) increments, just to the point where a further increase in fluid pressure does not significantly improve fluid atomization. Refer to the following example.

**Example:**

Pump Ratio		Pump Air Regulator Increment psi (MPa, bar)	=	Incremental Fluid Pressure psi (MPa, bar)
15:1	x	7 (.05, 0.5)	=	100 (0.7, 7.0)
30:1	x	3.3 (0.02, 0.2)	=	100 (0.7, 7.0)

5. If you are using an air-assisted spray gun, see **Adjust the Spray Pattern** on page 12.

## Adjust the Spray Pattern

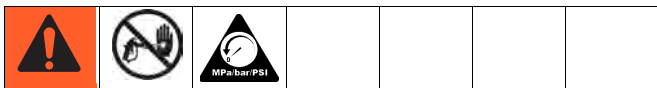

**NOTE:** Use this procedure with air-assisted spray guns only.

1. See FIG. 4. Close off pattern adjustment air by turning knob (AA) clockwise (in) all the way. This sets gun for its widest pattern.

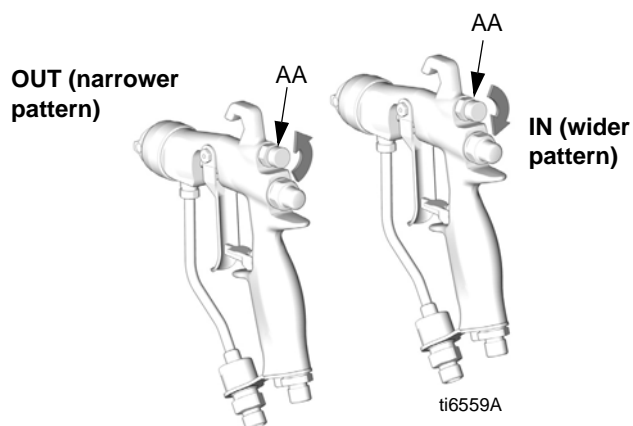

**FIG. 4. Pattern Air Knob**

2. See FIG. 5. Set atomizing air pressure at about 5 psi (0.35 bar, 35 kPa) when triggered. Check spray pattern, then slowly increase air pressure until tails are completely atomized and pulled into spray pattern. Do not exceed 100 psi (0.7 MPa, 7 bar) air pressure to gun.

3. See FIG. 4. For narrower pattern, turn pattern adjustment valve knob (AA) counterclockwise (out). If pattern is still not narrow enough, increase air pressure to gun slightly or use different size tip.

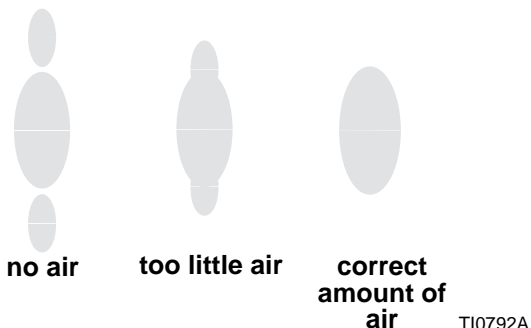

**FIG. 5. Spray Pattern Problems**

## Shutdown



Follow **Pressure Relief Procedure**, page 10.

Always flush the pump before the fluid dries on the displacement rod. See **Flush the Pump** on page 13.

# Maintenance

## Tighten Threaded Connections

Before each use, check all hoses for wear or damage. Replace as necessary. Check that all threaded connections are tight and leak-free.

## Flush the Pump



Flush the pump:

- Before first use
- When changing colors or fluids
- Before repairing equipment
- Before fluid dries or settles out in a dormant pump (check the pot life of catalyzed fluids)
- At the end of the day
- Before storing the pump.

Flush at the lowest pressure possible. Flush with a fluid that is compatible with the fluid you are pumping and with the wetted parts in your system. Check with your fluid manufacturer or supplier for recommended flushing fluids and flushing frequency.

1. Follow **Pressure Relief Procedure**, page 10.
2. Remove tip guard and spray tip from gun. Refer to separate gun manual.
3. Place suction tube in grounded metal pail containing cleaning fluid.
4. Set pump to lowest possible fluid pressure, and start pump.
5. Hold a metal part of the gun firmly to a grounded metal pail.
6. Trigger gun. Flush system until clear solvent flows from gun.
7. Follow **Pressure Relief Procedure**, page 10.
8. Clean the tip guard, spray tip, and fluid filter element separately, then reinstall them.
9. Clean inside and outside of suction tube and suction hose.

# Troubleshooting

					
<p><b>Relieve the pressure</b> before checking or servicing the equipment.</p>					

**NOTE:** Check all possible problems and causes before disassembling the pump.

Problem	Cause	Solution
Air motor will not run.	Damaged air valve (214).	Replace or service air valve (214). See page 18.
	Damaged pilot valve (213).	Replace pilot valves (213). See page 20.
Air continuously exhausting around air motor piston rod.	Damaged u-cups (207).	Replace piston rod u-cups (207). See page 22.
Air continuously exhausting from muffler.	Damaged air valve plate (305) or cup (312).	Replace or service air valve (214). See page 18.
Air motor “bounces” at top of stroke.	Damaged bottom pilot valve (213).	Replace bottom pilot valve (213). See page 20.
Air motor “bounces” at bottom of stroke.	Damaged top pilot valve (213).	Replace top pilot valve (213). See page 20.
Icing inside motor.	Air motor operating at high pressure or high cycle rate.	Reduce pressure, cycle rate, or duty cycle of motor.
		Reduce dew point of compressed air in moisture coalescing filter.
Pump fails to operate.	Restricted line or inadequate air supply; closed or clogged valves.	Clear line or increase air supply. Check that the valves are open.
	Obstructed fluid hose or gun; fluid hose ID is too small.	Open, clear*; use hose with larger ID.
	Fluid dried on the displacement rod (119).	Clean; keep the packing nut wet-cup filled with Graco throat seal liquid (TSL).
Pump operates but does not prime.	Held open or worn ball check valves or piston packings.	Clear valve; replace packings. See page 16.
	Worn suction hose o-ring (38).	Replace suction hose o-ring (38).
Pump operates, but output is low on both strokes.	Restricted line or inadequate air supply; closed or clogged valves.	Clear line or increase air supply. Check that the valves are open.
	Obstructed fluid hose or gun; fluid hose ID is too small.	Open, clear*; use hose with larger ID.
	Worn packings in displacement pump.	Replace packings. See page 16.
Pump operates, but output is low on downstroke.	Held open or worn ball check valves or piston packings.	Clear valve; replace packings. See page 16.
Erratic or accelerated pump speed.	Exhausted fluid supply.	Refill and prime.
	Held open or worn ball check valves or packings.	Clear valve, replace packings. See page 16.
Fluid being pumped is visible in the packing nut wet-cup.	Worn throat packings.	Tighten packing nut.
		Replace throat packings. See page 16.
Bad spray pattern.	Clean or repair spray gun or tip.	See G15/G40 air-assisted gun manual or Silver Plus airless gun manual.

# Repair

## General Information

- Reference numbers and letters in parentheses in the text refer to the callouts in the figures and the parts drawing.
- Always use Genuine Graco Parts and Accessories, available from your Graco distributor. If you supply your own accessories, be sure they are adequately sized and pressure rated for your system.

## To Remove Intake Valve Only

The intake ball and seat may be cleaned or serviced without disconnecting the displacement pump.



1. Stop the pump.
2. Flush the pump, if possible (see page 13). Follow **Pressure Relief Procedure**, page 10.
3. Disconnect the suction hose.
4. Remove the intake housing (110). See FIG. 7.
5. Clean or replace the ball guide (109), ball (116), seat (117), and o-ring (111).
6. Install the o-ring (111‡), seat (117), intake ball (116‡), and ball guide (109) in the intake housing (110).
7. Screw the intake housing (110) onto the cylinder (105). Torque to 70-80 ft-lb (95-108 N•m).

## Disconnect the Displacement Pump



1. Stop the pump.
2. Flush the pump, if possible (see page 13). Follow **Pressure Relief Procedure**, page 10.
3. Disconnect the air hose, fluid hose, and suction hose.
4. See FIG. 6. Push the safety spring (9) down and hold to access the coupling pin (18). Push the retaining spring (19) up and push out the pin, using a screwdriver or punch.
5. Loosen the jam nut (13).
6. Unscrew the displacement pump by hand and place on work bench.

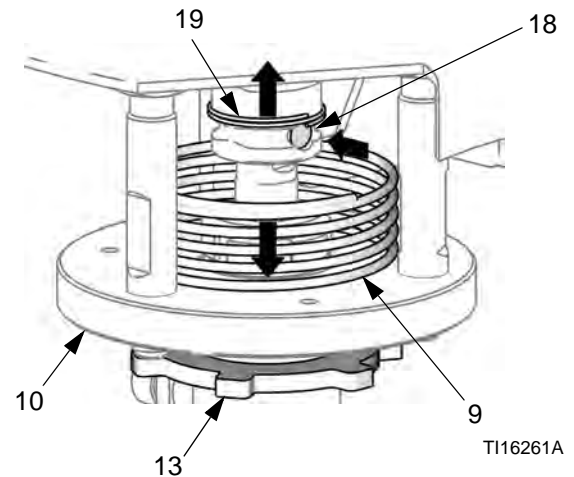

**FIG. 6. Safety Spring and Connecting Pin**

## Disassemble the Pump

**NOTE:** Pump Repair Kits are available. See page 31 to order the correct kit for your pump. Parts are marked with an ‡.

1. Follow the instructions under **Disconnect the Displacement Pump**, page 15.
1. See FIG. 7. Loosen the packing nut (103), using a screwdriver and hammer. Remove the o-ring (104).
2. Unscrew the cylinder (105) from the intake housing (110). The rod and piston assembly will come with the cylinder.
3. Remove the ball guide (109), intake ball (116), seat (117), and o-ring (111) from the intake housing (110).
4. Drive the rod and piston assembly out the bottom of the cylinder. Remove the o-ring (107) from the cylinder.
5. Insert a plastic rod in the bottom of the cylinder and drive the throat packings and glands out the top.
6. Put the rod (119) in a vise and unscrew the piston (124). Be careful not to drop the piston ball (120). Disassemble the piston packings from the piston.
7. Clean and inspect all parts. Replace any damaged parts.

## Reassemble the Pump

**NOTE:** Soak the leather packings (113‡, 125‡) in hydraulic oil for one hour before installing them in the pump.

1. Install the piston wiper (123‡) on the piston (124), with the lips facing down. Install the female gland (122‡). Install the piston packings in the following order with the lips facing up: blue UHMWPE (126‡), leather (125‡), UHMWPE, leather, UHMWPE. Install the male gland (121‡).
2. Put the displacement rod (119) in a vise. Place the piston ball (120‡) in the cavity of the rod. Screw the piston assembly into the rod. Torque to 24-30 ft-lb (33-40 N•m).

3. Install the male gland (114‡) in the cylinder (105). Install the throat packings in the following order with the lips facing down: blue UHMWPE (106‡), leather (113‡), UHMWPE, leather, UHMWPE. Install the female gland (112‡).
4. Install the o-ring (104‡) on the packing nut (103). Loosely install the packing nut in the cylinder.
5. Liberally lubricate the piston packings and the top 2 in. (51 mm) of the displacement rod (119).
6. Push the displacement rod (119) into the cylinder (105) from the bottom until the piston is completely in the cylinder and the rod protrudes from the packing nut (103).
7. Grease the o-ring (107‡) and install it on the cylinder (105).
8. Install the o-ring (111‡), seat (117), intake ball (116‡), and ball guide (109) in the intake housing (110).
9. Place the intake housing (110) in a vise. Screw the cylinder (105) into the intake housing. Torque to 70-80 ft-lb (95-108 N•m).
10. Tighten the packing nut (103) 1/2 turn past hand-tight, or torque to 60-80 in-lb (6.7-9.0 N•m).
11. Ensure that the button plug (102‡) is in place on the packing nut (103).
12. Follow the instructions under **Reconnect the Displacement Pump**, page 16.

## Reconnect the Displacement Pump

### NOTICE

The displacement pump can be damaged if the stroke is not centered when the pump is reconnected. Be sure to fully screw the displacement pump into the adapter plate (10).

1. Screw the displacement pump into the adapter plate (10) until it stops. Back off pump less than 1 turn, to align pump outlet as desired.



2. Tighten the jam nut (13). Torque to 65-75 ft-lb (88-102 N•m).
3. Align the hole in the displacement rod with the hole in the air motor rod. Use a screwdriver to push in the pin (18).
4. Push the retaining spring (19) into place to cover the pin.
5. Fill throat packing nut wet-cup with TSL to prevent premature packing wear.

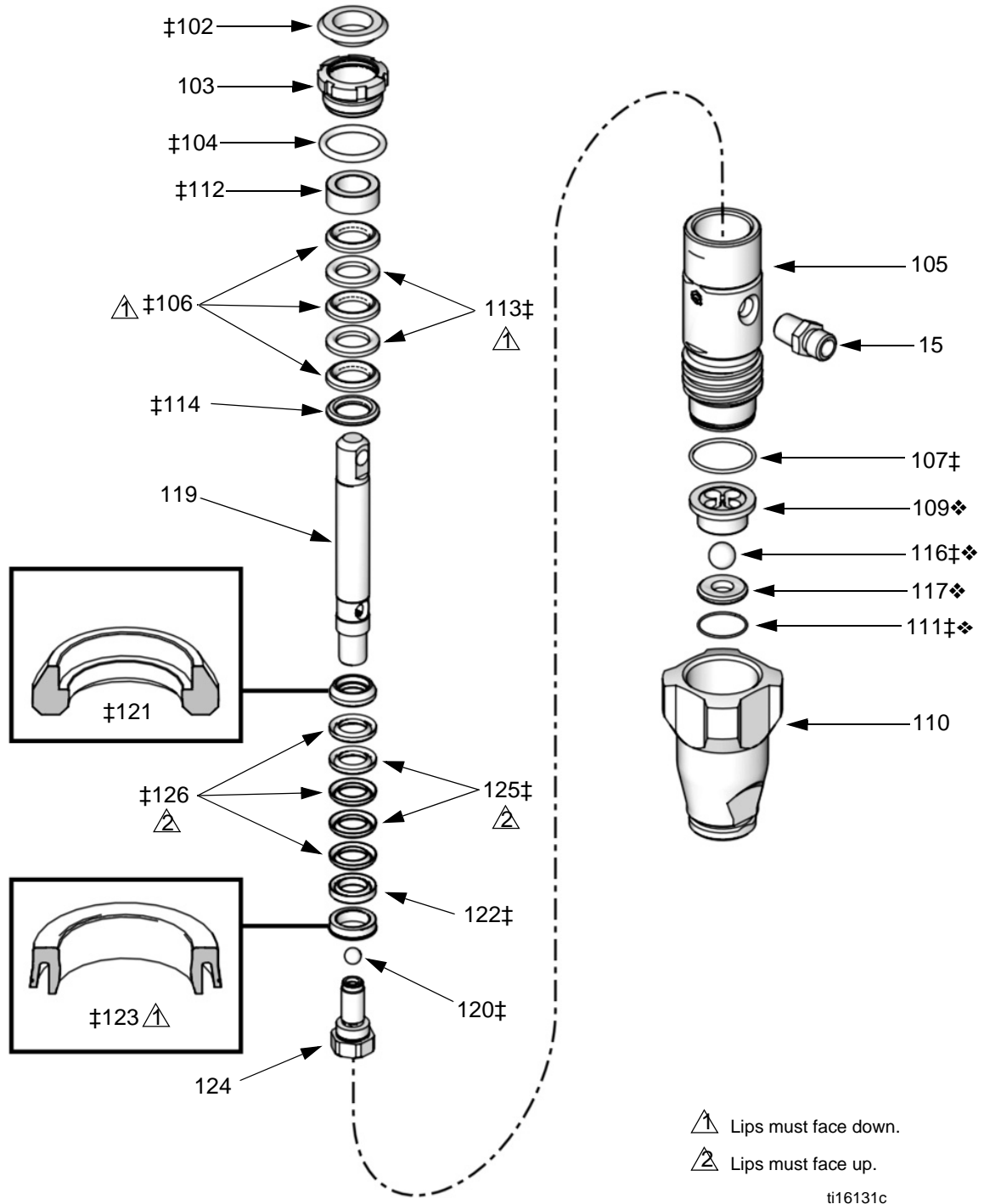

FIG. 7. Displacement Pump

## Repair Air Valve



### Replace Complete Air Valve

1. Stop the pump. Follow **Pressure Relief Procedure**, page 10.
2. Disconnect the air line to the motor.
3. See FIG. 14 on page 23. Remove four screws (211). Remove the air valve (214) and gasket (209\*♦).
4. To repair the air valve, go to **Disassemble the Air Valve**, page 18. To install a replacement air valve, continue with step 5.
5. Align the new air valve gasket (209\*♦) on the manifold, then attach the air valve (214). Torque screws (211) to 95-105 in-lb (11-12 N•m).
6. Reconnect the air line to the motor.

### Replace Seals or Rebuild Air Valve

**NOTE:** Air Valve Seal Kits are available. See page 35. Parts are marked with an †.

Air Valve Repair Kits are available. See page 35. Parts are marked with an ♦.

Air Valve End Cap Kits are available. See page 35. Parts are marked with an ⌘.

### Disassemble the Air Valve

1. Perform steps 1-3 under **Replace Complete Air Valve**, page 18.
2. See FIG. 8. Use a 2 mm or 5/64 hex key to remove two screws (309†♦). Remove the valve plate (305♦), cup (312♦), and spring (311♦).

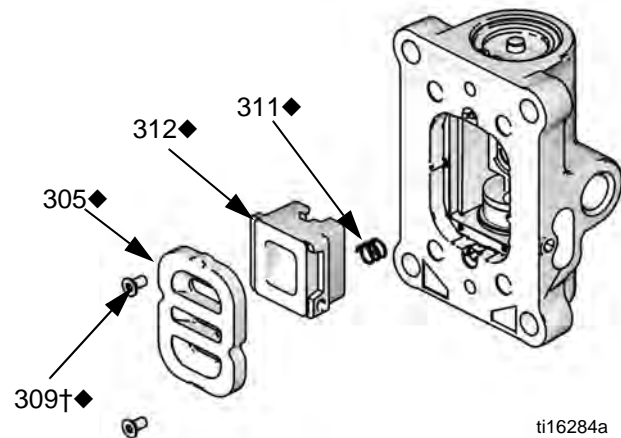

**FIG. 8. Air Plate Removal**

3. See FIG. 9. Remove the snap ring (310⌘) from each end. Use the piston to push the end caps (307⌘) out of the ends. Remove end cap o-rings (306†⌘♦).
4. Remove the piston (302♦). Remove the u-cup seals (308†♦) from each end and the detent assembly (303♦) and detent cam (304♦) from the center.

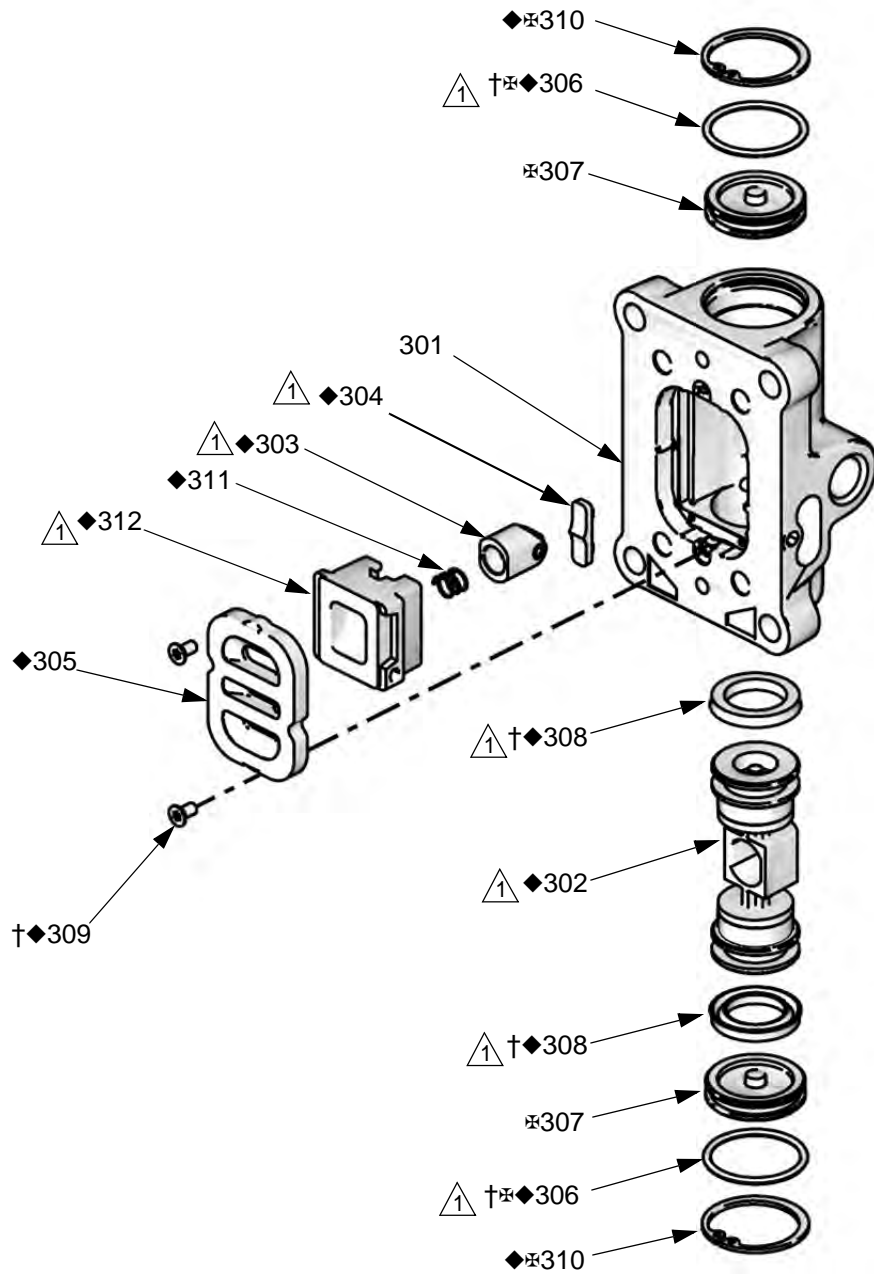

ti16213a

 Apply lubricant.

**FIG. 9. Air Valve Assembly**

### Reassemble the Air Valve

1. See FIG. 9. Lubricate detent cam (304♦) and install into housing.
2. See FIG. 10. Lubricate the u-cups (308†♦) and install on the piston (302♦) with lips facing toward the center of the piston.

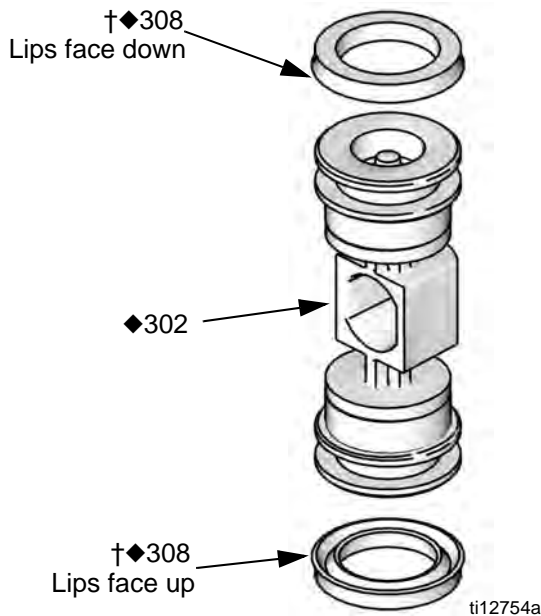

**FIG. 10. Air Valve U-cup Installation**

3. See FIG. 9. Lubricate both ends of the piston (302♦) and install it in the housing.
4. Lubricate and install the detent assembly (303♦) into the piston.
5. Lubricate new o-rings (306†⊗♦) and install on the end caps (307⊗). Install the end caps into the housing.
6. Install a snap ring (310♦⊗) on each end to hold end caps in place.

7. Install the spring (311♦). Lubricate and install the air valve cup (312♦), see FIG. 11. Align the small round magnet with the air inlet.
8. Install the valve plate (305♦). Tighten the screws (309†♦) to hold it in place.

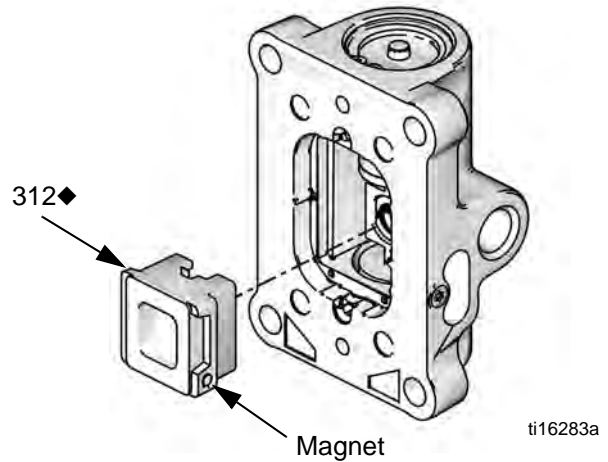

**FIG. 11. Air Valve Cup Installation**

### Replace Pilot Valves

1. Stop the pump. Follow **Pressure Relief Procedure**, page 10.
2. Disconnect the air line to the motor.
3. See FIG. 12. Push the safety spring (9) down and hold to access the pilot valve on the bottom cover.
4. See FIG. 14 on page 23. Use a 10 mm wrench to remove the old pilot valves (213) from the top and bottom covers.
5. Lubricate and install the new pilot valves (213). Torque to 95-105 in-lb (11-12 N•m).

## Disconnect the Air Motor



1. Stop the pump.
2. Flush the pump, if possible (see page 13). Follow **Pressure Relief Procedure**, page 10.
3. Disconnect the air hose, fluid hose, and suction hose.
4. See FIG. 12. Push the safety spring (9) down and hold to access the coupling pin (18). Push the retaining spring (19) up and push out the pin, using a screwdriver or punch.
5. Remove the nuts (11) from the bottom of the tie rods (8).
6. Remove the pump lower (12). The adapter plate (10) will remain attached to the lower.
7. Remove the safety spring (9).
8. Loosen the nuts (17) at the top of the tie rods, then remove the tie rods. The mounting bracket (1) is loosened from the motor as the tie rods are removed.
9. Take the motor to a work bench. See **Repair Air Motor** on page 22.

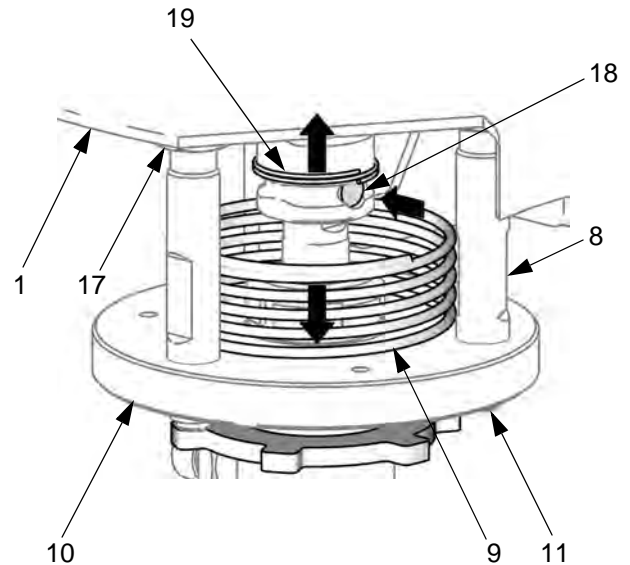

TI16261A

**FIG. 12. Disconnect the Air Motor**

## Reconnect the Air Motor

1. Replace the motor on the mounting bracket (1).
  2. Screw the tie rods into the motor, with the top hex nuts (17) attached. Torque the tie rods to 5-10 ft-lb (7-13 N•m).
- NOTE:** Always tighten the tie rods before tightening the top hex nuts (17).
3. Tighten the top hex nuts (17) to secure the mounting bracket (1).
  4. Slide the pump with the adapter plate (10) attached onto the tie rods (8). Ensure that the safety spring (9) is in place and the pump outlet is oriented as desired.
  5. Install the tie rod nuts (11). Torque to 100 in-lb (11 N•m).
  6. Align the hole in the displacement rod with the hole in the air motor rod. Use a screwdriver to push in the pin (18).
  7. Push the retaining spring (19) into place to cover the pin.

## Repair Air Motor



**NOTE:** Complete Air Motor Replacement Kits are available. Order 24G693 (2.5 in. motor) or 24G694 (3.5 in. motor).

**NOTE:** Air Motor Seal Kits are available. See page 33 for the correct kit for your motor. Parts included in the kit are marked with an asterisk (\*). For best results, use all the parts in the kit.

### Disassemble the Air Motor

1. See FIG. 14. Use a 10 mm socket wrench to remove four screws (211). Remove the air valve (214) and gasket (209\*♦†).
2. Remove four screws (211) and remove the manifold (220) and two gaskets (208\*).
3. Use a 10 mm socket wrench to remove the pilot valves (213) from the top and bottom cover.
4. Use a 13 mm socket wrench to remove the tie bolts (212).
5. Remove the top cover (210). Remove the o-ring (202\*). *On 3.5 in. motors only*, remove the plug (231) and o-ring (230\*).
6. Remove the shield (206) and cylinder (205).
7. Remove the o-ring (204\*) from the piston.
8. Secure the piston (219) in a vise with soft jaws. Use a wrench on the flats of the rod (218) to remove the rod and bottom cover assembly (201) from the piston.
9. Remove the rod from the bottom cover assembly.
10. Remove retaining ring (217), u-cup seals (207\*), and o-ring (202\*) from the bottom cover.

### Reassemble the Air Motor

**NOTE:** For easier reassembly, start with the top cover (210) turned over on the workbench and assemble the air motor upside-down.

1. Lubricate and install the o-ring (202\*) on the top cover (210).
2. Lubricate the inside of the cylinder (205). Lower the cylinder onto the top cover (210).
3. Install the shield (206) around the cylinder (205) and in the groove on the top cover (210).
4. See FIG. 13. Lubricate and install new u-cup seal (207\*) in the bottom of the bearing in the bottom cover (201). The lips must face down. Lubricate and install new u-cup seal (207\*) in the top of the bearing. Lips must face up. Install retaining ring (217).

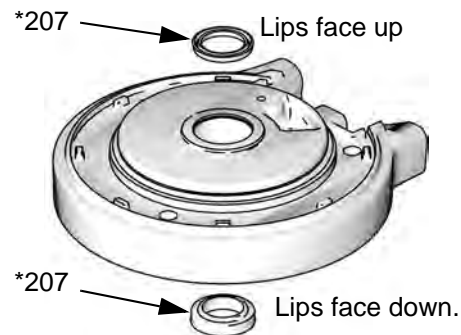

ti16285a

**FIG. 13. Air Motor U-cup Installation**

⚠ Apply lubricant.

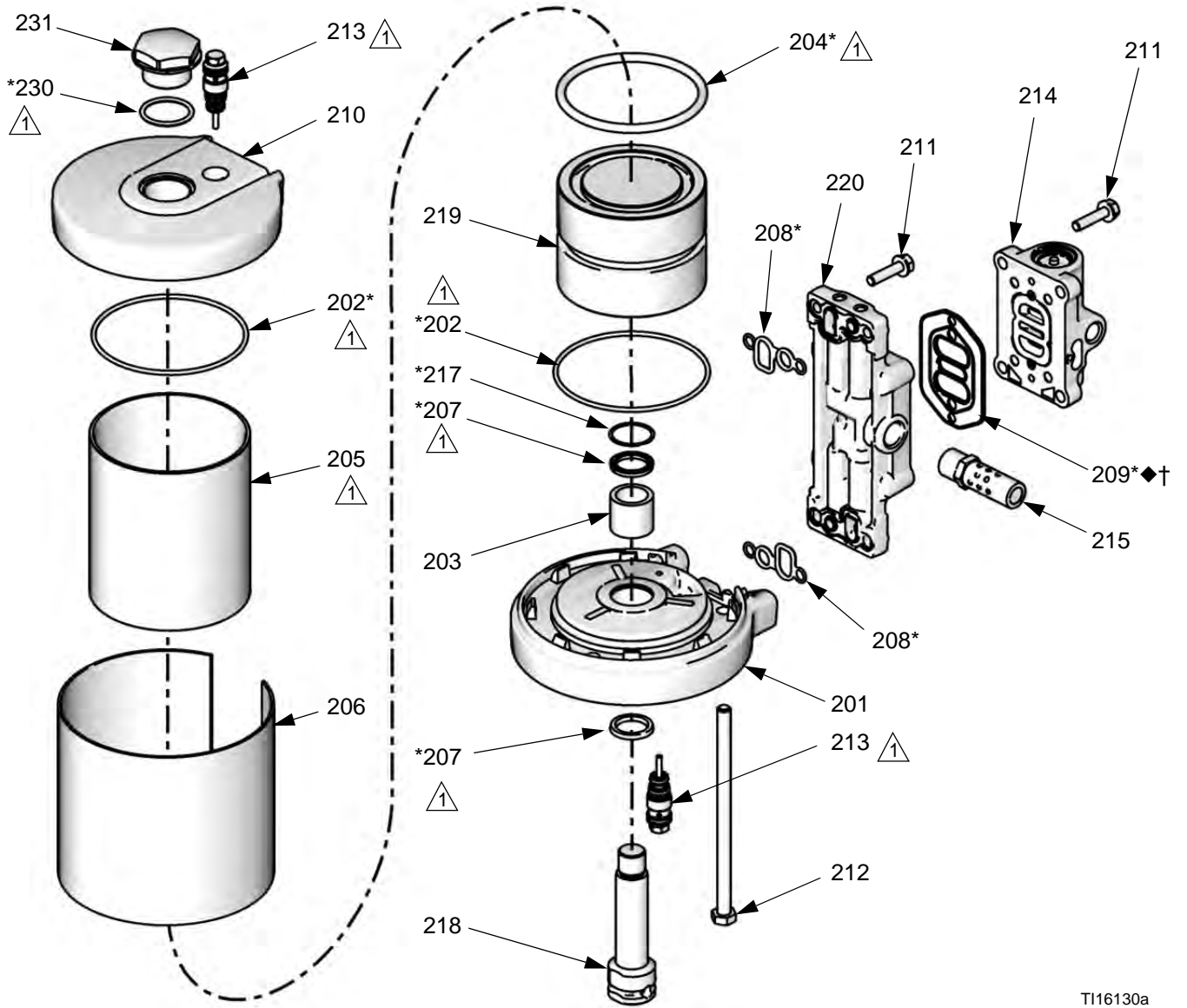

T116130a

FIG. 14. Air Motor Assembly

5. Lubricate and install the o-ring (202\*) on the bottom cover (201).
6. Carefully push the threaded end of the rod (218) up through the bottom cover (201).
7. Apply 16G561 adhesive to the threads of the rod (218). Screw the piston (219) onto the rod. Place the piston in a vise with soft jaws and torque to 35-40 ft-lb (47-54 N•m).
8. Lubricate and install the o-ring (204\*) on the piston (219).
9. See FIG. 15. Carefully place the bottom cover/piston assembly on the cylinder (205), sliding the piston (219) into the cylinder. The manifold surfaces of the top and bottom covers must align. Be sure the shield (206) is in the groove on both the top and bottom covers.

10. Install the tie bolts (212) hand tight.
11. Install two gaskets (208\*) on the manifold (220). Install the manifold (220). Torque screws (211) to 95-105 in-lb (10.7-11.9 N•m).

**NOTE:** The manifold is reversible for ease of placement of muffler or remote exhaust.

12. Align the air valve gasket (209\*♦†) on the manifold, then attach the air valve (214). Torque screws (211) to 95-105 in-lb (11-12 N•m).
13. Tighten the tie bolts (212) halfway. Work in a criss-cross pattern. Check that the shield (206) remains in the grooves on both covers. Continue tightening the bolts in pattern to 11-13 ft-lb (15-18 N•m).
14. *On 3.5 in. motors only*, lubricate the o-ring (230\*). Install it and the plug (231) in the top cover (210).
15. Lubricate and install pilot valves (213) in top and bottom cover. Torque to 95-105 in-lb (11-12 N•m).
16. See **Reconnect the Air Motor** on page 21.

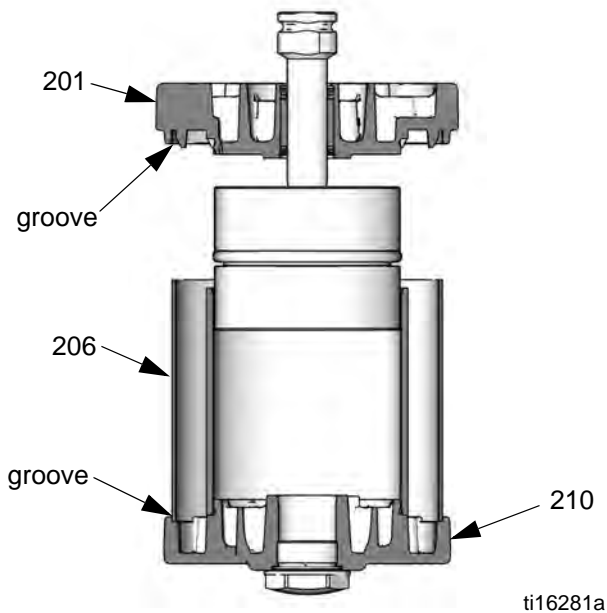

**FIG. 15. Align Shield in Grooves on Covers**



# Parts

## Package Parts

**NOTE:** For hose and gun, see page 29.

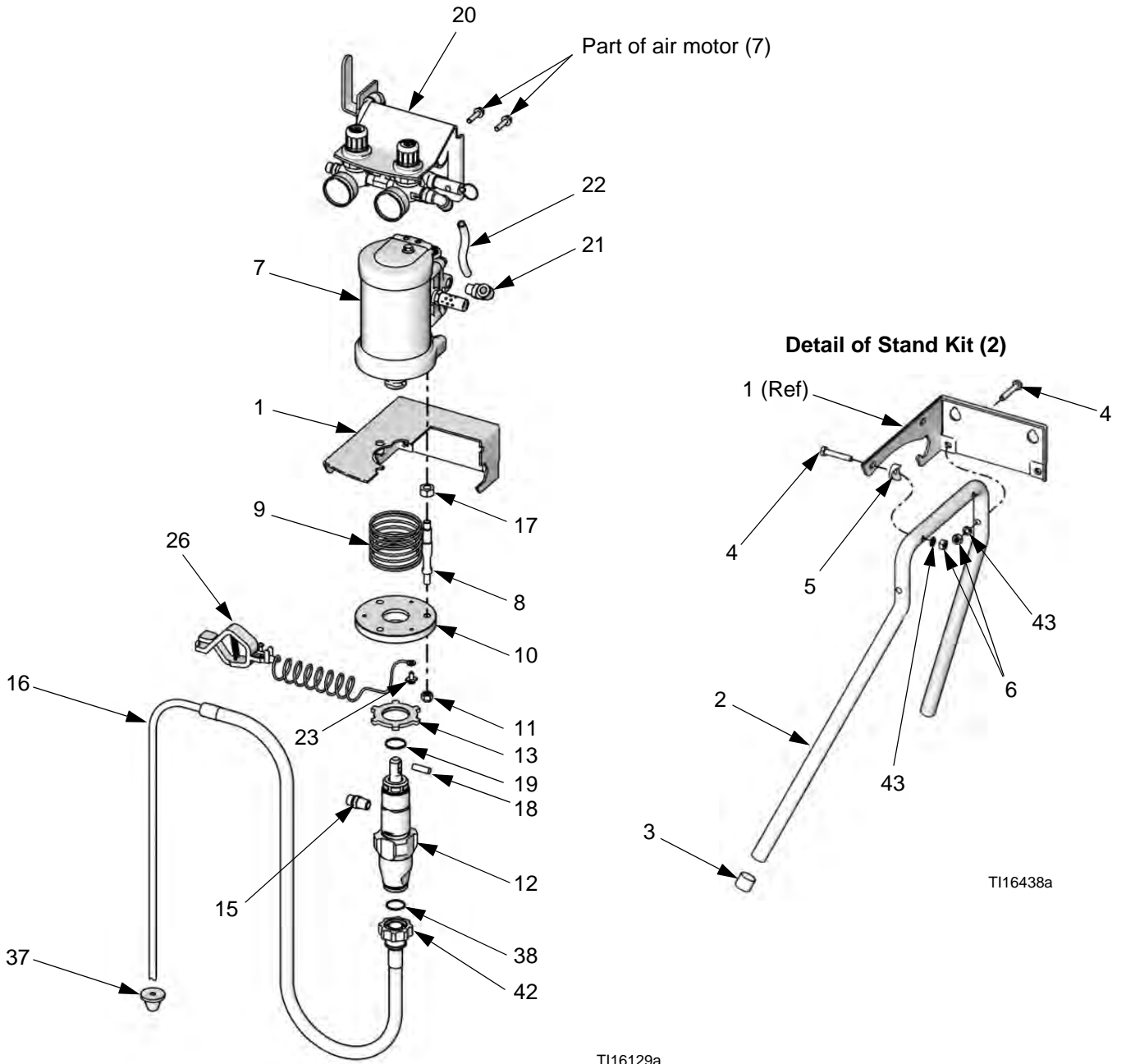

## Package Parts 15:1 Ratio Pumps

Ref. No.	Description	Package							Qty
		24F150	24F151	24W281	24F158	24F159	24W283	24X311	
1	BRACKET, wall	24H102	24H102	24H102	24H102	24H102	24H102	24H102	1
2	KIT, stand; includes items 3, 4, 5, 6, and 43 below, and 418 on page 36		24F164	24F164		24F164	24F164		1
3	PLUG		108175	108175		108175	108175		4
4	SCREW, cap, hex hd; 1/4-20 x 1.5 in. (38 mm)		100058	100058		100058	100058		6
5	SPACER, tube		---	---		---	---		4
6	NUT, hex; 1/4-20		100015	100015		100015	100015		6
7	MOTOR, air; see page 32	24G693	24G693	24G693	24G693	24G693	24G693	24G693	1
8	KIT, rod, tie; includes rods and items 11 and 17 (3 of each)	24G707	24G707	24G707	24G707	24G707	24G707	24G707	1
9	SPRING, safety	24H103	24H103	24H103	24H103	24H103	24H103	24H103	1
10	ADAPTER, pump lower	24H104	24H104	24H104	24H104	24H104	24H104	24H104	1
11	NUT, lock	104541	104541	104541	104541	104541	104541	104541	3
12	LOWER, pump; see page 30; also includes items 15, 18, and 19	24G701	24G701	24G701	24G702	24G702	24G702	24G701	1
13	NUT, jam	195150	195150	195150	195150	195150	195150	195150	1
15‡	NIPPLE; 1/4 npsm x 1/4 npt; plated steel	162453	162453	162453				162453	1
	NIPPLE; 1/4 npsm x 1/4 npt; sst				166846	166846	166846		1
16	KIT, suction hose, 5 gal. (19 l); 3/8 in. (10 mm) OD; includes items 37 (qty 1), 38, and 42	24F148	24F148		24F148	24F148		24F148	1
17	NUT, hex; 7/16-20	Not sold separately. Order Tie Rod Kit, item 8.							3
18‡	PIN, straight	196762	196762	196762	196762	196762	196762	196762	1
19‡	SPRING, retaining	196750	196750	196750	196750	196750	196750	196750	1
20	AIR CONTROL ASSEMBLY; see page 36	24H162	24H163	24H163	24H162	24H163	24H163	24H162	1
21	ELBOW, swivel; 1/4 npt(m) x 3/8 in. (10 mm) OD tube	121141	121141	121141	121141	121141	121141	121141	1
22	TUBE, polyurethane; 3/8 in. (10 mm) OD; 2 ft (0.61 m)	24H008	24H008	24H008	24H008	24H008	24H008	24H008	1
23	SCREW, ground	116343	116343	116343	116343	116343	116343	116343	1
26	WIRE, grounding	238909	238909	238909	238909	238909	238909	238909	1
28	THROAT SEAL LIQUID; 4 oz (not shown)	238049	238049	238049	238049	238049	238049	238049	1
37	STRAINER, suction; 3/8 in. (10 mm) OD tube; pack of 3	24F160	24F160		24F160	24F160		24F160	1
38	O-RING; fluoroelastomer	117559	117559		117559	117559		117559	1
42	NUT, jam, suction	15E813	15E813		15E813	15E813		15E813	1
43	WASHER, lock; 1/4; part of stand kit (2)		---	---		---	---		6
44*	HOPPER, kit			17A493			17A493		1

‡ Included in Pump Lower Rebuild Kit. See page 31.

\* Not shown. See Merkur ES Hopper Kit manual 334011 for more information.

## Package Parts 30:1 Ratio Pumps

Ref. No.	Description	Package								Qty
		24F152	24F153	24W287	24F154	24F155	24F156	24F157	24W285	
1	BRACKET, wall	24H102	24H102	24H102	24H102	24H102	24H102	24H102	24H102	1
2	KIT, stand; includes items 3, 4, 5, 6, and 43 below, and 418 on page 36		24F164	24F164		24F164		24F164	24F164	1
3	PLUG		108175	108175		108175		108175	108175	4
4	SCREW, cap, hex hd; 1/4-20 x 1.5 in. (38 mm)		100058	100058		100058		100058	100058	6
5	SPACER, tube		---	---		---		---	---	4
6	NUT, hex; 1/4-20		100015	100015		100015		100015	100015	6
7	MOTOR, air; see page 32	24G694	24G694	24G694	24G694	24G694	24G694	24G694	24G694	1
8	KIT, rod, tie; includes rods and items 11 and 17 (3 of each)	24G707	24G707	24G707	24G707	24G707	24G707	24G707	24G707	1
9	SPRING, safety	24H103	24H103	24H103	24H103	24H103	24H103	24H103	24H103	1
10	ADAPTER, pump lower	24H104	24H104	24H104	24H104	24H104	24H104	24H104	24H104	1
11	NUT, lock	104541	104541	104541	104541	104541	104541	104541	104541	3
12	LOWER, pump; see page 30; also includes items 15, 18, and 19	24G702	24G702	24G702	24G701	24G701	24G701	24G701	24G701	1
13	NUT, jam	195150	195150	195150	195150	195150	195150	195150	195150	1
15‡	NIPPLE; 1/4 npsm x 1/4 npt; plated steel				162453	162453	162453	162453	162453	1
	NIPPLE; 1/4 npsm x 1/4 npt; sst	166846	166846	166846						1
16	KIT, suction hose, 5 gal. (19 l); 3/8 in. (10 mm) OD; includes items 37 (qty 1), 38, and 42	24F148	24F148		24F148	24F148	24F148	24F148		1
17	NUT, hex; 7/16-20	Not sold separately. Order Tie Rod Kit, item 8.								3
18‡	PIN, straight	196762	196762	196762	196762	196762	196762	196762	196762	1
19‡	SPRING, retaining	196750	196750	196750	196750	196750	196750	196750	196750	1
20	AIR CONTROL ASSEMBLY; see page 36	24H162	24H163	24H163	24H164	24H165	24H162	24H163	24H163	1
21	ELBOW, swivel; 1/4 npt(m) x 3/8 in. (10 mm) OD tube	121141	121141	121141	121141	121141	121141	121141	121141	1
22	TUBE, polyurethane; 3/8 in. (10 mm) OD; 2 ft (0.61 m)	24H008	24H008	24H008	24H008	24H008	24H008	24H008	24H008	1
23	SCREW, ground	116343	116343	116343	116343	116343	116343	116343	116343	1
26	WIRE, grounding	238909	238909	238909	238909	238909	238909	238909	238909	1
28	THROAT SEAL LIQUID; 4 oz (not shown)	238049	238049	238049	238049	238049	238049	238049	238049	1
37	STRAINER, suction; 3/8 in. (10 mm) OD tube; pack of 3	24F160	24F160		24F160	24F160	24F160	24F160		1
38	O-RING; fluoroelastomer	117559	117559		117559	117559	117559	117559		1
42	NUT, jam, suction	15E813	15E813		15E813	15E813	15E813	15E813		1
43	WASHER, lock; 1/4; part of stand kit (2)		---	---		---		---	---	6
44*	HOPPER, kit			17A493					17A493	1

‡ Included in Pump Lower Rebuild Kit. See page 31.

\* Not shown. See Merkur ES Hopper Kit manual 334011 for more information.



# Hose and Gun

**Air-Assisted Packages**

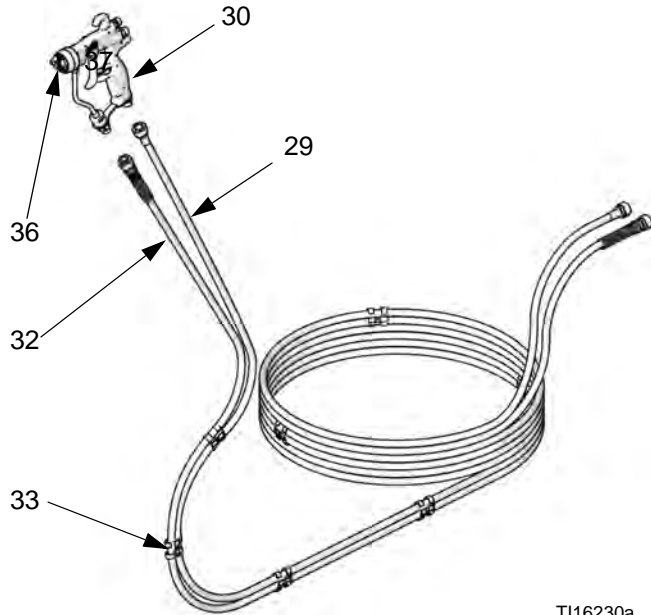

**Airless Packages**

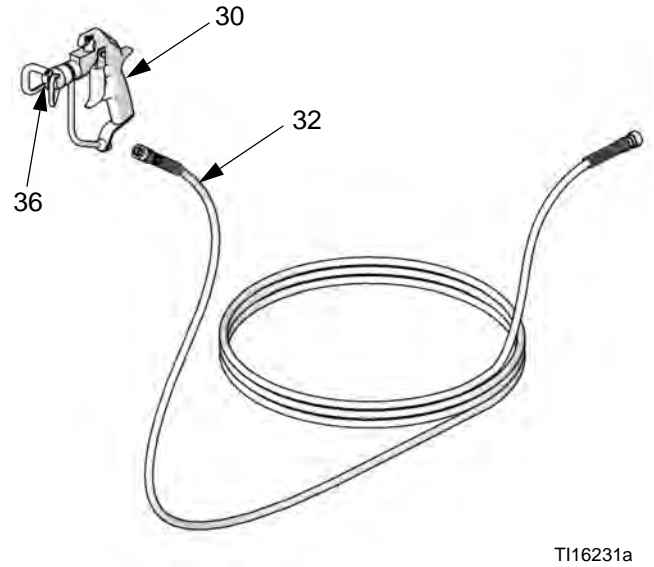

Ref. No.	Description	Package							Qty
		24F150 24F151 24W281	24F152 24F153 24W287	24F154 24F155	24F156 24F157 24W285	24F158 24F159 24W283	24X311*		
29	HOSE, air, gun	241811	241811		241811	241811		1	
30	GUN, air-assisted, G15; see 3A0149	24C853				24C853		1	
	GUN, air-assisted, G40; see 3A0149		24C855		24C855			1	
	GUN, airless; see 311254			235460				1	
32	HOSE, fluid; 1/8 in. (3 mm) ID nylon; 1/4 npsm(f) plated steel couplings; 25 ft (7.6 m) long	24F165		24F165	24F165			1	
	HOSE, fluid; 1/8 in. (3 mm) ID nylon; 1/4 npsm(f) sst couplings; 25 ft (7.6 m) long		24F166			24F166		1	
33	CLIP, hose; pack of 7	24H005	24H005		24H005	24H005		7	
36★	TIP; G15, G40	AAF412	AAF412		AAF412	AAF412		1	
	TIP; airless			163515				1	

★ Additional tip sizes are available. See manual 3A0149 for G15 and G40 AA Guns. See tip manual 306686 for Silver Plus Airless Guns.

\* 24X311 includes an outlet fluid hose (3/16 in x4.5', P/N 238959) for connection to the mix manifold.

# Displacement Pump Parts

Part No. 24G701, Plated Steel

Part No. 24G702, Stainless Steel

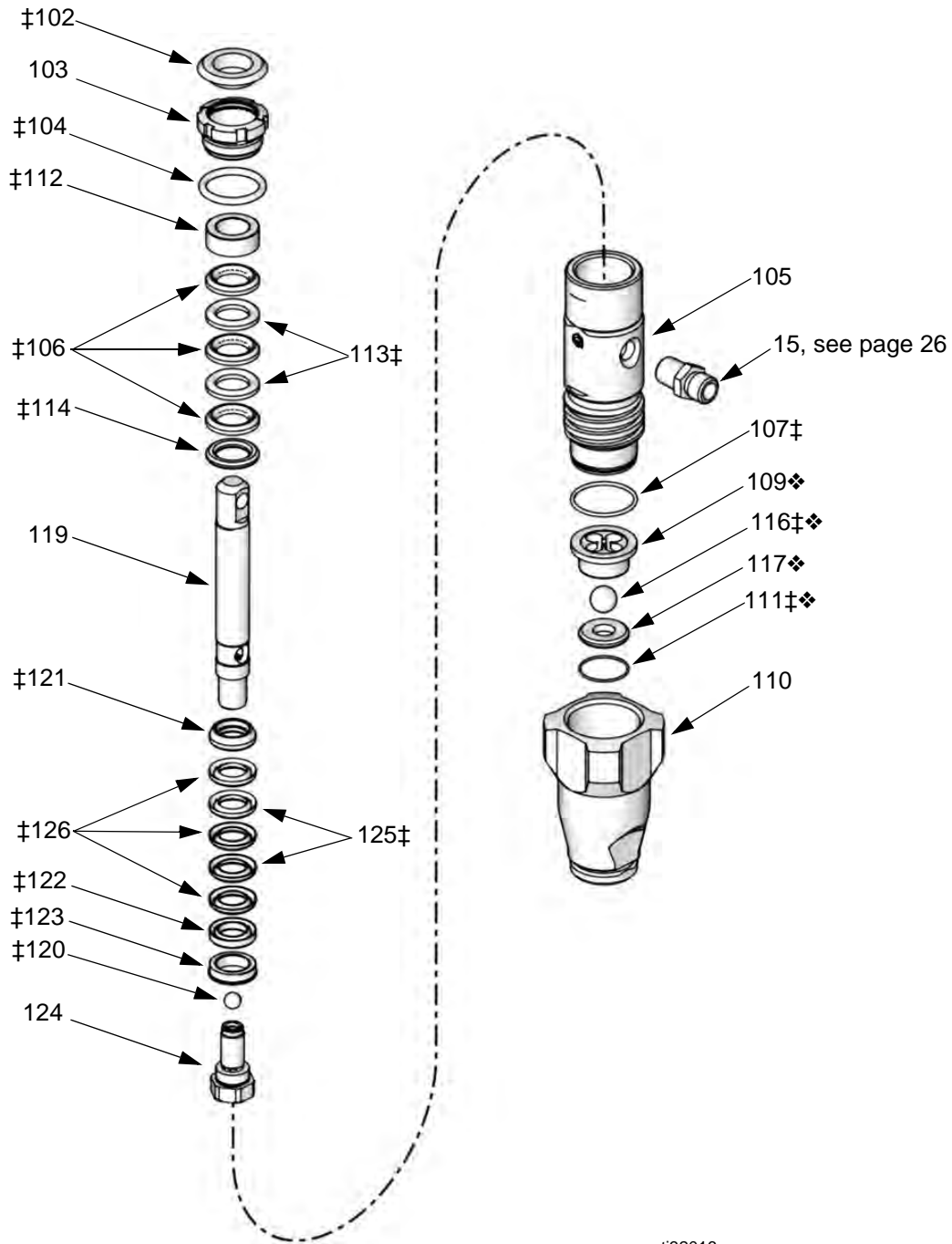

ti32016a

## Displacement Pump Parts

### Part No. 24G701, Plated Steel

### Part No. 24G702, Stainless Steel

Ref.	Description	24G701	24G702	Qty
102‡	BUTTON, plug	---	---	1
103	NUT, packing; plated steel	193047		1
	NUT, packing; sst		24H161	1
104‡	O-RING; buna-N; 1.262 in. (32.05 mm) OD	---	---	1
105	CYLINDER, pump	17D481	24G706	1
106‡	V-PACKING, throat; V-Max™ UHMWPE	---	---	3
107‡	O-RING; PTFE; 1.254 in. (31.85 mm) OD	---	---	1
109❖	GUIDE, ball	15C011	15C011	1
110	VALVE, intake housing; plated steel	15B611		1
	VALVE, intake housing; sst		24H007	1
111‡ ❖	O-RING; PTFE; 0.941 in. (23.90 mm) OD	---	---	1
112‡	GLAND, female, throat; acetal	---	---	1
113‡	V-PACKING, throat; leather	---	---	2
114‡	GLAND, male, throat; acetal	---	---	1
116‡ ❖	BALL, intake; sst; 0.500 in. (13 mm) dia.	105445	105445	1
117❖	SEAT, carbide	15A968	15A968	1
119	KIT, rod, displacement; Chromex™; includes item 124, and items 18 and 19 on page 25	24G703	24G704	1
120‡	BALL, piston; sst; 0.3125 in. (7.94 mm) dia.	105444	105444	1
121‡	GLAND, male, piston; plated steel	---		1
	GLAND, male, piston; sst		---	1
122‡	GLAND, female, piston; plated steel	---		1
	GLAND, female, piston; sst		---	1
123‡	WIPER, piston	---	---	1
124	VALVE, piston; plated steel	Order item 119		1
	VALVE, piston; sst		Order item 119	1
125‡	V-PACKING, piston; leather	---	---	2
126‡	V-PACKING, piston; V-Max™ UHMWPE	---	---	3

‡ Included in Pump Lower Rebuild Kit. Order Kit 24H006 for Pump 24G701, or Kit 24G705 for Pump 24G702.

❖ Included in Intake Check Valve Kit 246429.

# Air Motor Parts

Part No. 24G693, 2.5 in. (63.5 mm)

Part No. 24G694, 3.5 in. (88.9 mm), shown

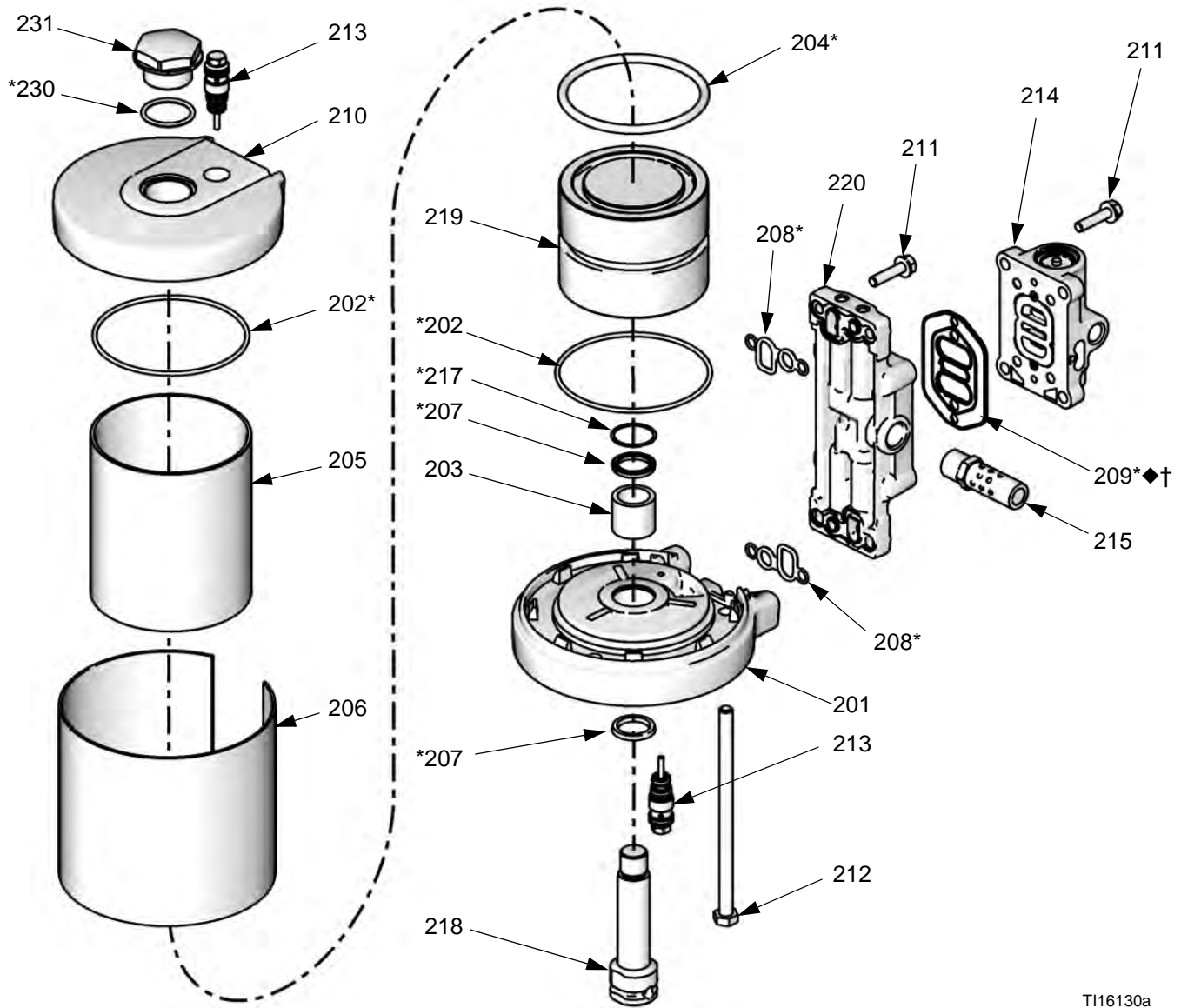

T116130a



## Air Motor Parts

### Part No. 24G693, 2.5 in. (63.5 mm)

### Part No. 24G694, 3.5 in. (88.9 mm), shown

Ref.	Description	24G693	24G694	Qty
201	KIT, cover, bottom; includes 202 (qty 1), 203, 207, 213 (qty 1), and 217	24G695	24G696	1
202*	O-RING, cover	Not sold separately. See Air Motor Seal Kit (below), Bottom Cover Kit (201, this table), or Top Cover Kit (210, this table)		2
203	BEARING	Not sold separately. See Bottom Cover Kit (201, this table)		1
204*	O-RING, piston	Not sold separately. See Air Motor Seal Kit (below) or Piston Kit (219, this table)		1
205	CYLINDER, motor	15M289	15M211	1
206▲	COVER, cylinder (includes English warning label)	15M302	15M212	1
207*	SEAL, u-cup	Not sold separately. See Air Motor Seal Kit (below) or Bottom Cover Kit (201, this table)		2
208*	GASKET, manifold	Not sold separately. See Air Motor Seal Kit (below) or Manifold Assembly (220, this table)		2
209*♦†	GASKET, air valve	Not sold separately. See Air Motor Seal Kit, Valve Repair Kit 24A537, Valve Seal Kit 24A535 (below), or Manifold Assembly (220, this table)		1
210	KIT, cover, top; includes 202 and 213 (qty 1 of each). 15X353 also includes 230 and 231.	24H004	15X353	1
211	SCREW, M6 x 25	Not sold separately. See Manifold Assembly (220, this table) or Air Valve Replacement Kit (page 35)		8
212	BOLT, tie, hex head	15M314		2
	BOLT, tie, hex head		15M314	3
213	VALVE, pilot (pack of 2)	24A366	24A366	1
214	VALVE, air; includes items 209 and 211 (qty 4)	24A351	24A351	1
215	MUFFLER	15M213	15M213	1
217*	RING, retaining	Not sold separately. See Air Motor Seal Kit (below) or Bottom Cover Kit (201, this table)		1
218	ROD, air motor	Not sold separately. See Motor Piston Kit (219, this table)		1
219	KIT, piston, motor; includes 204 and 218, and 16G561 adhesive.	24G697	24G698	1
220	MANIFOLD, assembly, includes 208, 209, and 211 (qty. 4)	24A579	24A579	1
229▲	LABEL, warning (French and Spanish)	15W719	15W719	1
230*	O-RING, top plug (24G694 only)		Not sold separately. See Air Motor Seal Kit (below)	1
231	PLUG, top cover (24G694 only)		Not sold separately. See Top Cover Kit (210, this table)	1

▲ Replacement Danger and Warning labels, tags, and cards are available at no cost.

† Included in Air Valve Seal Kit 24A535. See page 35.

♦ Included in Air Valve Repair Kit 24A537. See page 35.

\* Included in Air Motor Seal Kit:

24G693 (2.5 in. Motor)	24G694 (3.5 in. Motor)
24G699	24G700

# Air Valve Parts

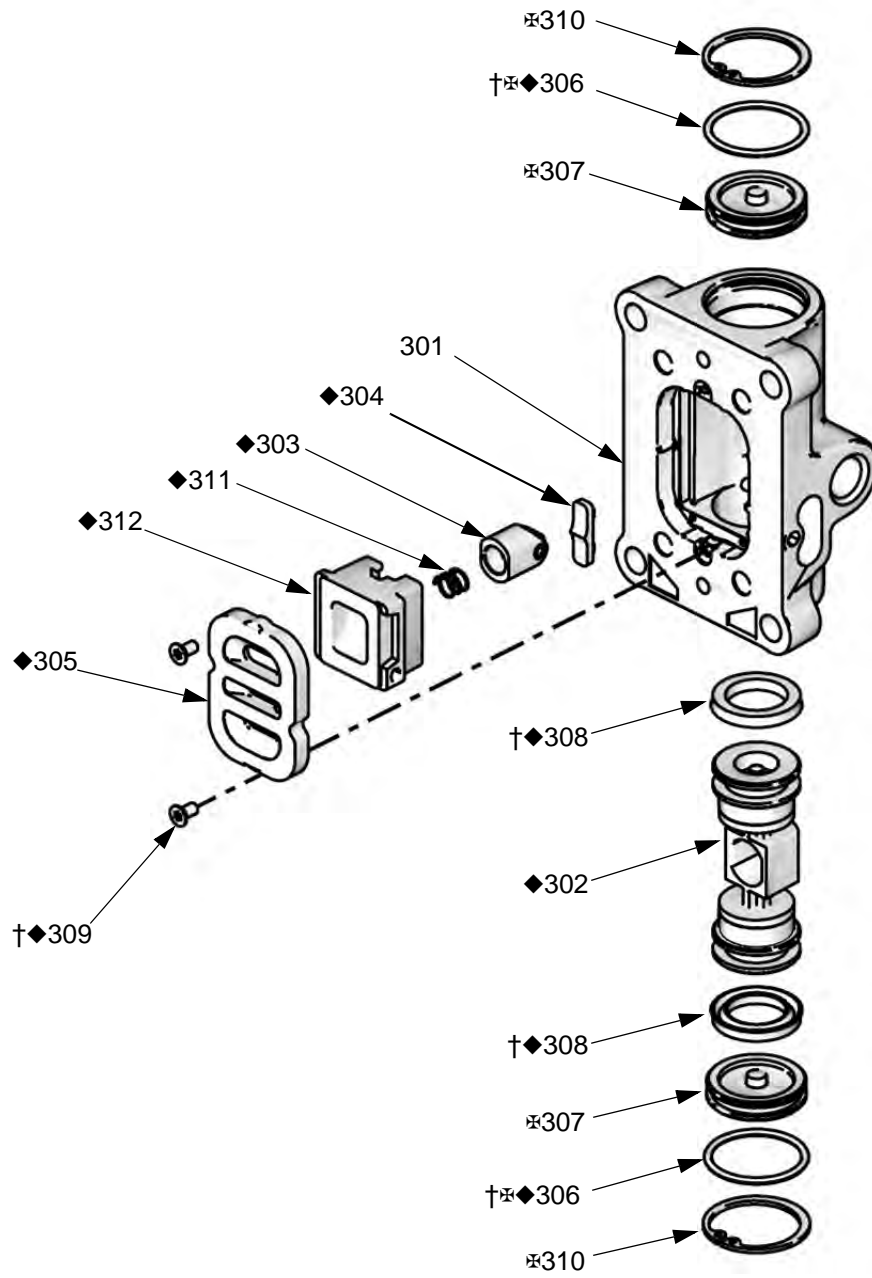

ti16213a

## Air Valve Parts

### Complete Air Valve Replacement Kit 24A351

To replace the complete air valve, order Air Valve Replacement Kit 24A351. The kit includes items 301-312 below, and items 209 and 211 on page 33.

### Air Valve Repair Kits

Air valve parts are not sold individually. The table below shows possible kit options for each part.

Ref.	Description	Qty	Air Valve Repair Kit 24A537	Air Valve Seal Kit 24A535	Air Valve End Cap Kit 24A360
301	HOUSING	1			
302◆	AIR VALVE PISTON	1	✓		
303◆	DETENT PISTON ASSEMBLY	1	✓		
304◆	DETENT CAM	1	✓		
305◆	PLATE, air valve	1	✓		
306†‡◆	O-RING	2	✓	✓	✓
307‡	CAP	2			✓
308†◆	U-CUP	2	✓	✓	
309†◆	SCREW	2	✓	✓	
310‡	SNAP RING	2	✓		✓
311◆	DETENT SPRING	1	✓		
312◆	CUP	1	✓		

† Included in Air Valve Seal Kit 24A535.

◆ Included in Air Valve Repair Kit 24A537.

‡ Included in Air Valve End Cap Kit 24A360.

Replacement screws (309) are available in a pack of 10. Order Kit 24A359.

## Air Control Parts

**Part No. 24H162, Air-Assisted, Wall Mount**

**Part No. 24H163, Air-Assisted, Stand Mount**

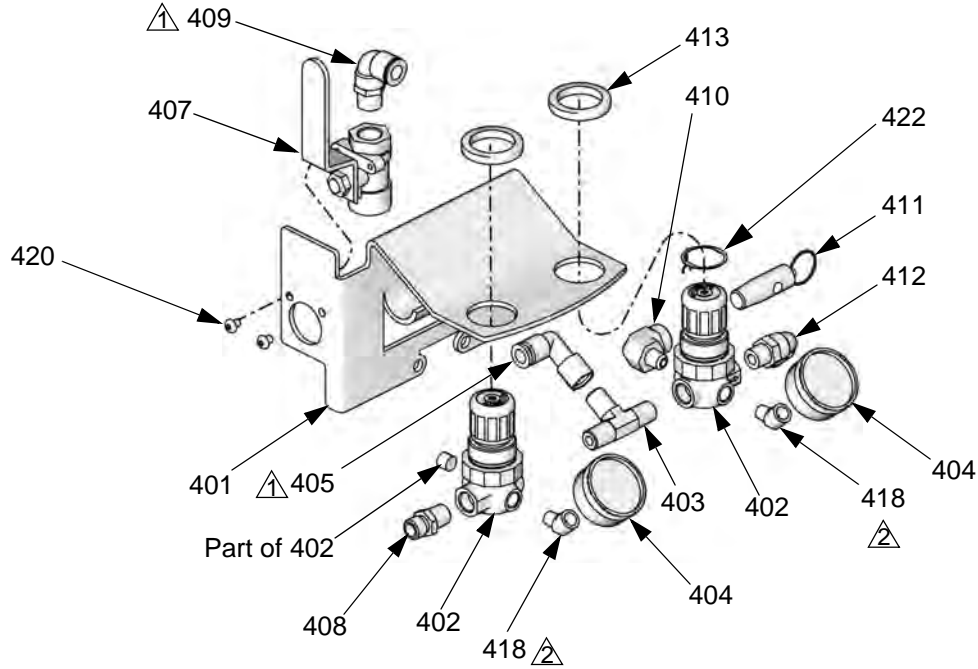

TI16132a

 Connect tubing (406) between these two fittings.

 Used on stand mount units only.

**Part No. 24H164, Airless, Wall Mount**

**Part No. 24H165, Airless, Stand Mount**

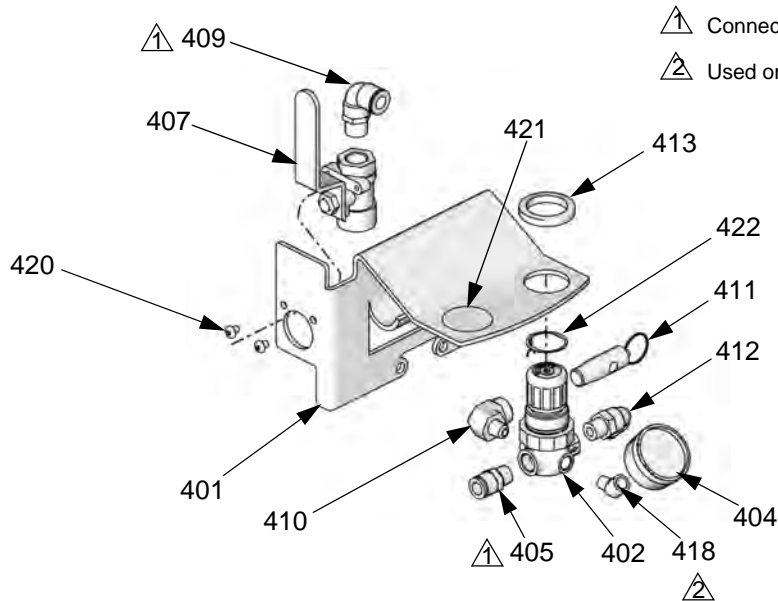

 Connect tubing (406) between these two fittings.

 Used on stand mount units only.

TI16229a

## Air Control Parts

**Part No. 24H162, Air-Assisted, Wall Mount**

**Part No. 24H163, Air-Assisted, Stand Mount**

**Part No. 24H164, Airless, Wall Mount**

**Part No. 24H165, Airless, Stand Mount**

Ref.	Description	24H162	24H163	24H164	24H165	Qty
401	BRACKET, handle	24H105	24H105	24H105	24H105	1
402	REGULATOR, air	15T499	15T499			2
	REGULATOR, air			15T499	15T499	1
403	TEE; 1/4 npt(m)	115219	115219			1
404	GAUGE, air pressure	108190	108190			2
	GAUGE, air pressure			108190	108190	1
405	ELBOW, tube; 1/4 npt(f) x 3/8 in. (10 mm) OD tube	C38161	C38161			1
	FITTING, tube; 1/4 npt(m) x 3/8 in. (10 mm) OD tube			120389	120389	1
406	TUBE, polyurethane; 3/8 in. (10 mm) OD tube; 2 ft (0.61 m)	24H008	24H008	24H008	24H008	1
407	VALVE, ball, air; 3/8 npt(fbe)	114362	114362	114362	114362	1
408	NIPPLE; 1/4 npsm x 1/4 npt	162453	162453			1
409	ELBOW, swivel; 3/8 npt(m) x 3/8 in. (10 mm) OD tube	16F151	16F151	16F151	16F151	1
410	ELBOW; 1/4 npt(f) x 1/8 npt(m)	121150	121150	121150	121150	1
411	VALVE, safety relief; 110 psi	113498	113498	113498	113498	1
412	ELBOW, swivel; 1/4 npt(m) x 3/8 in. (10 mm) OD tube	121141	121141	121141	121141	1
413	NUT, regulator	115244	115244			2
	NUT, regulator			115244	115244	1
418	ELBOW, street, 45°; 1/8 npt (mxf)		113630			2
	ELBOW, street, 45°; 1/8 npt (mxf)				113630	1
420	SCREW, cap, button-hd; 10-24 x 3/8 in. (10 mm)	114381	114381	114381	114381	2
421	PLUG, panel			16F547	16F547	1
422	RING, grounding	24P812	24P812	24P812	24P812	1

## Kits and Accessories

<b>Kit Description</b>	<b>Part No.</b>
<b>Airless to Air-Assisted Conversion Kit</b>	24F161
<b>Inline Fluid Filter, stainless steel</b>	24F271
<b>Inline Fluid Filter, aluminum</b>	24F272
<b>Standard Suction Hose, 5 gal. (19 l), 3/8 in. (10 mm) OD</b>	24F148
<b>Suction Hose, 5 gal. (19 l), 5/8 in. (16 mm) OD</b>	24F149
<b>Suction Tube, 1 gal. (3.8 l), 11/32 in. (9 mm) OD</b>	24F147
<b>Standard Push-on Strainer Kit</b>	24F160
<b>Screw-on Strainer Kit (for 24F149 5/8 in. Suction Hose Kit)</b>	256426
<b>Air Gauge Lens Cover Kit (sheet of 12 covers)</b>	193199
<b>Throat Seal Liquid (TSL); 4 oz (118 ml)</b>	238049
<b>Throat Seal Liquid (TSL); 8 oz (236 ml)</b>	206994
<b>Alternate U-Cup Pump Packing Kit (UHMWPE)</b>	24H665
<b>Hopper Kit</b>	17A493
<b>Hopper Screens (Pack of 5)</b>	17B207
<b>Hopper O-Ring Kit</b>	17B208
<b>Hopper Bungee Cord Kit</b>	17C166

# Package Dimensions

Package	A, inch (mm)	B, inch (mm)	C inch (mm)	D inch (mm)
Wall Mount		20.2 (513)		
Stand Mount	29.0 (737)		17.4 (442)	18.4 (467)
Stand Mount with Hopper	29.0 (737)		17.4 (442)	26.5 (673)

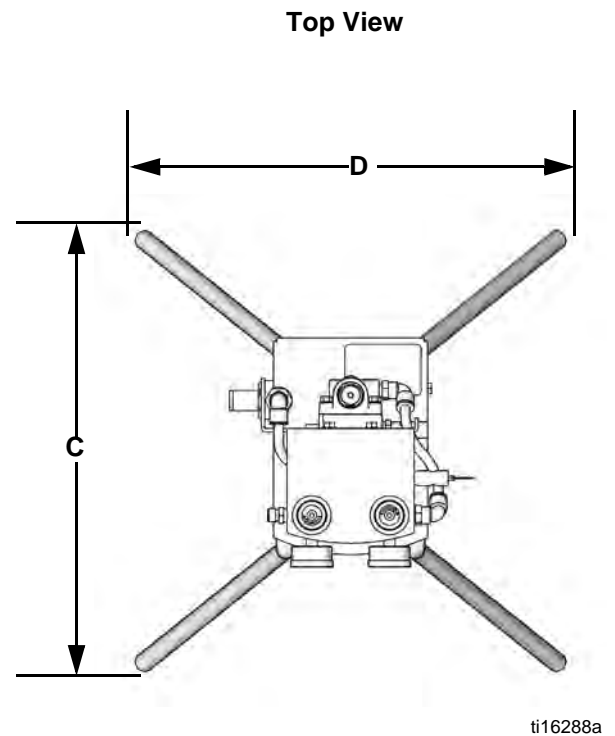
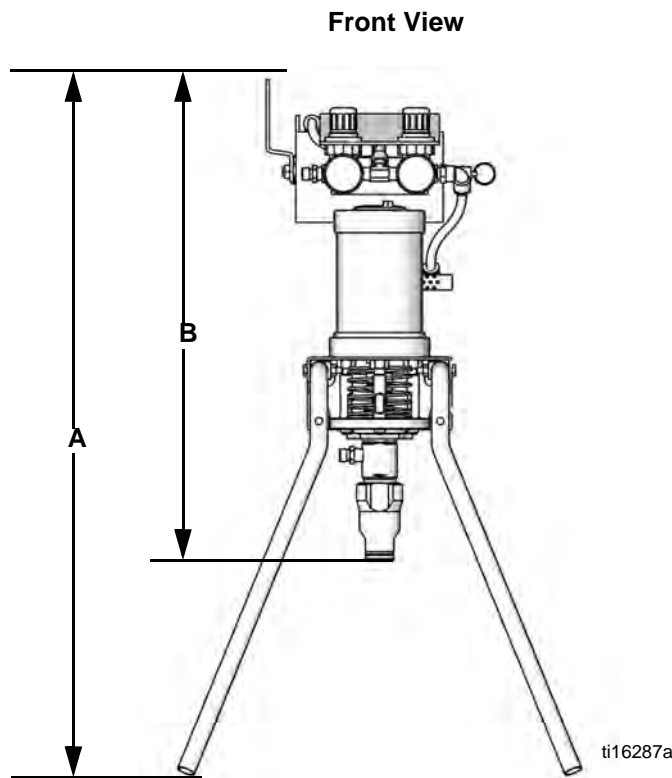

# Package Weights

Package	Description	lb	kg
24F150	15:1 plated steel, AA, wall	20	9
24F151	15:1 plated steel, AA, stand	23	10
24F152	30:1 stainless steel, AA, wall	23	10
24F153	30:1 stainless steel, AA, stand	26	12
24F154	30:1 plated steel, airless, wall	22	10
24F155	30:1 plated steel, airless, stand	25	11
24F156	30:1 plated steel, AA, wall	23	10
24F157	30:1 plated steel, AA, stand	26	12
24F158	15:1 stainless steel, AA, wall	20	9

Package	Description	lb	kg
24F159	15:1 stainless steel, AA, stand	23	10
24W281	15:1 plated steel, AA, stand, hopper	32	15
24W283	15:1 stainless steel, AA, stand, hopper	32	15
24W285	30:1 plated steel, AA, stand, hopper	35	16
24W287	30:1 stainless steel, AA, stand, hopper	35	16
24X311	15:1 plated steel, AA, all, bare	15	7

# Wall Bracket Mounting Hole Diagram

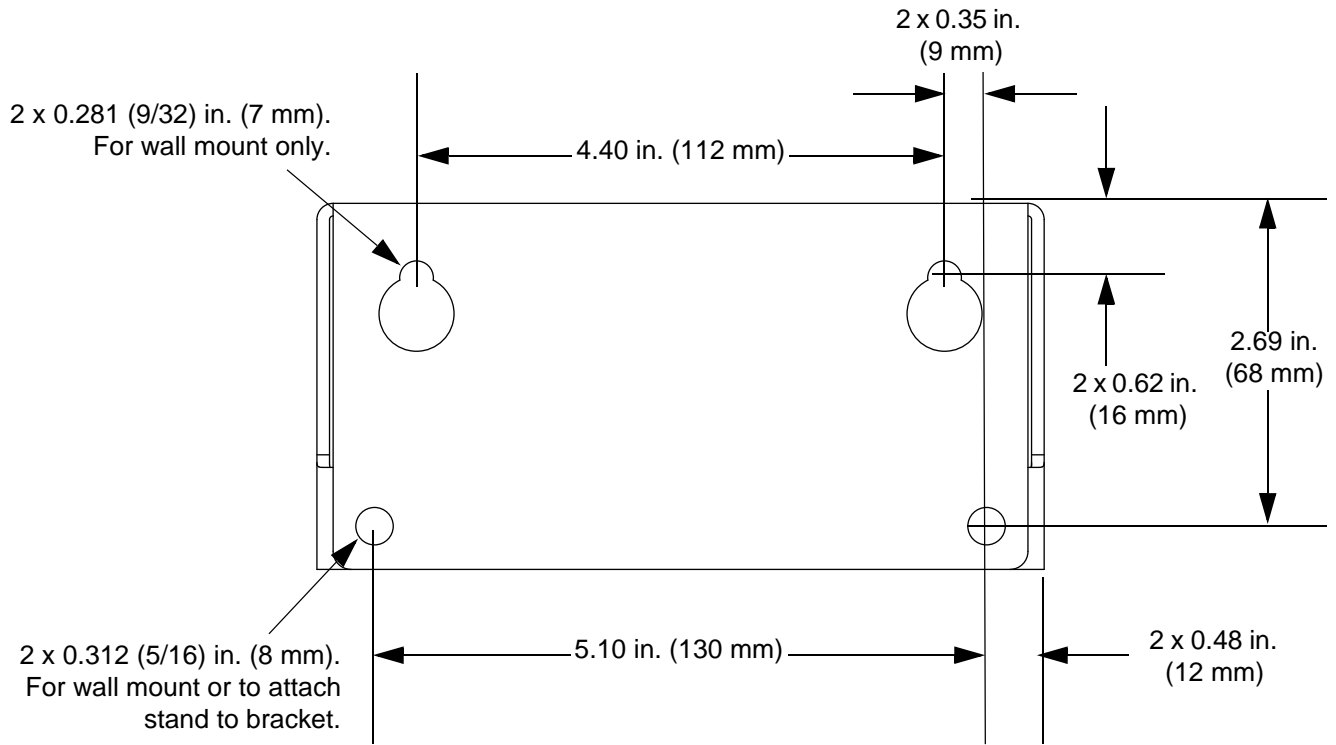

T116289a



# Technical Data

Maximum fluid working pressure	
15:1 Pumps . . . . .	1500 psi (10.3 MPa, 103 bar)
30:1 Pumps . . . . .	3000 psi (20.7 MPa, 207 bar)
Maximum air inlet pressure . . . . . 100 psi (0.7 MPa, 7.0 bar)	
Ratio . . . . . 15:1 or 30:1 (see <b>Models</b> , page 3)	
Maximum fluid temperature . . . . . 160°F, 71°C	
Ambient air temperature range . . . . . 35-120°F, 2-49°C	
Package air inlet size . . . . . 3/8 npt(f)	
Package fluid outlet size . . . . . 1/4 npsm(m)	
Maximum motor speed . . . . . 240 cycles per minute	
(Do not exceed maximum recommended speed of fluid pump, to prevent premature pump wear.)	
Maximum spray tip orifice size . . . . . .019 in. (0.483 mm)	
Sound data	
24G693 Air Motor	
Sound power* . . . . .	83.2 dBA
Sound pressure** . . . . .	76.5 dBA
24G694 Air Motor	
Sound power* . . . . .	84.5 dBA
Sound pressure** . . . . .	77.9 dBA
Wetted parts	
Plated steel pumps . . . . .	Stainless steel, nickel plated carbon steel, tungsten carbide, ptfе, acetal, leather, ultra-high molecular weight polyethylene
Stainless steel pumps . . . . .	Stainless steel, tungsten carbide, ptfе, acetal, leather, ultra-high molecular weight polyethylene
Spray guns . . . . .	See manual 3A0149 (G15 and G40 AA guns) or 311254 (Silver Plus airless gun)
Fluid hose . . . . .	Nylon, plated or stainless steel
Suction assembly . . . . .	Stainless steel, nylon, acetal, fluoroelastomer, polyethylene

\* Sound power at 70 psi (0.48 MPa, 4.8 bar), 80 cpm. Sound power measured per ISO-9614-2.

\*\* Sound pressure was tested 3.28 feet (1 m) from equipment.

# Performance Charts

## 15:1 Ratio Pumps

### KEY

<b>A</b>	= 100 psi (0.7 MPa, 7 bar)
<b>B</b>	= 70 psi (0.5 MPa, 5 bar)
<b>C</b>	= 40 psi (0.3 MPa, 3 bar)
<b>—</b>	= fluid flow
<b>- - -</b>	= air flow

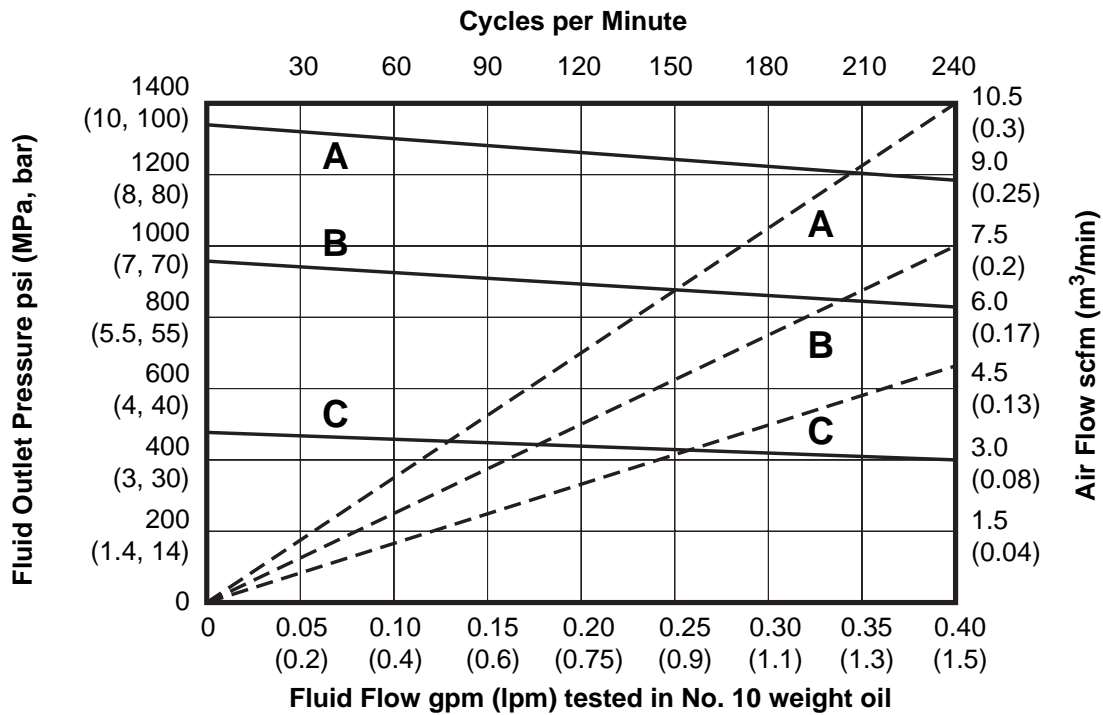

# 30:1 Ratio Pumps

## KEY

<b>A</b>	= 100 psi (0.7 MPa, 7 bar)
<b>B</b>	= 70 psi (0.5 MPa, 5 bar)
<b>C</b>	= 40 psi (0.3 MPa, 3 bar)
<b>—</b>	= fluid flow
<b>- - -</b>	= air flow

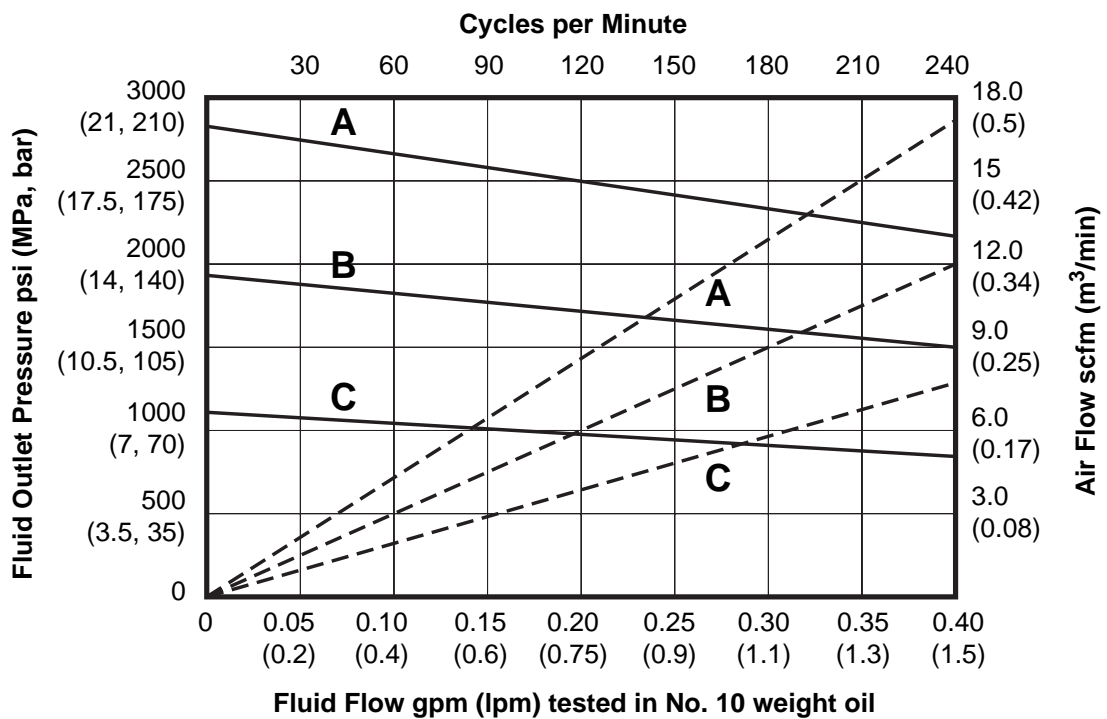

# Graco Standard Warranty

Graco warrants all equipment referenced in this document which is manufactured by Graco and bearing its name to be free from defects in material and workmanship on the date of sale to the original purchaser for use. With the exception of any special, extended, or limited warranty published by Graco, Graco will, for a period of twelve months from the date of sale, repair or replace any part of the equipment determined by Graco to be defective. This warranty applies only when the equipment is installed, operated and maintained in accordance with Graco's written recommendations.

This warranty does not cover, and Graco shall not be liable for general wear and tear, or any malfunction, damage or wear caused by faulty installation, misapplication, abrasion, corrosion, inadequate or improper maintenance, negligence, accident, tampering, or substitution of non-Graco component parts. Nor shall Graco be liable for malfunction, damage or wear caused by the incompatibility of Graco equipment with structures, accessories, equipment or materials not supplied by Graco, or the improper design, manufacture, installation, operation or maintenance of structures, accessories, equipment or materials not supplied by Graco.

This warranty is conditioned upon the prepaid return of the equipment claimed to be defective to an authorized Graco distributor for verification of the claimed defect. If the claimed defect is verified, Graco will repair or replace free of charge any defective parts. The equipment will be returned to the original purchaser transportation prepaid. If inspection of the equipment does not disclose any defect in material or workmanship, repairs will be made at a reasonable charge, which charges may include the costs of parts, labor, and transportation.

**THIS WARRANTY IS EXCLUSIVE, AND IS IN LIEU OF ANY OTHER WARRANTIES, EXPRESS OR IMPLIED, INCLUDING BUT NOT LIMITED TO WARRANTY OF MERCHANTABILITY OR WARRANTY OF FITNESS FOR A PARTICULAR PURPOSE.**

Graco's sole obligation and buyer's sole remedy for any breach of warranty shall be as set forth above. The buyer agrees that no other remedy (including, but not limited to, incidental or consequential damages for lost profits, lost sales, injury to person or property, or any other incidental or consequential loss) shall be available. Any action for breach of warranty must be brought within two (2) years of the date of sale.

**GRACO MAKES NO WARRANTY, AND DISCLAIMS ALL IMPLIED WARRANTIES OF MERCHANTABILITY AND FITNESS FOR A PARTICULAR PURPOSE, IN CONNECTION WITH ACCESSORIES, EQUIPMENT, MATERIALS OR COMPONENTS SOLD BUT NOT MANUFACTURED BY GRACO.** These items sold, but not manufactured by Graco (such as electric motors, switches, hose, etc.), are subject to the warranty, if any, of their manufacturer. Graco will provide purchaser with reasonable assistance in making any claim for breach of these warranties.

In no event will Graco be liable for indirect, incidental, special or consequential damages resulting from Graco supplying equipment hereunder, or the furnishing, performance, or use of any products or other goods sold hereto, whether due to a breach of contract, breach of warranty, the negligence of Graco, or otherwise.

## **FOR GRACO CANADA CUSTOMERS**

The Parties acknowledge that they have required that the present document, as well as all documents, notices and legal proceedings entered into, given or instituted pursuant hereto or relating directly or indirectly hereto, be drawn up in English. Les parties reconnaissent avoir convenu que la rédaction du présente document sera en Anglais, ainsi que tous documents, avis et procédures judiciaires exécutés, donnés ou intentés, à la suite de ou en rapport, directement ou indirectement, avec les procédures concernées.

# Graco Information

For the latest information about Graco products, visit [www.graco.com](http://www.graco.com).

For patent information, see [www.graco.com/patents](http://www.graco.com/patents).

**TO PLACE AN ORDER**, contact your Graco distributor or call to identify the nearest distributor.

**Phone:** 612-623-6921 **or Toll Free:** 1-800-328-0211 **Fax:** 612-378-3505

*All written and visual data contained in this document reflects the latest product information available at the time of publication.  
Graco reserves the right to make changes at any time without notice.*

Original instructions. This manual contains English. MM 3A0732

**Graco Headquarters:** Minneapolis

**International Offices:** Belgium, China, Japan, Korea

**GRACO INC. AND SUBSIDIARIES • P.O. BOX 1441 • MINNEAPOLIS MN 55440-1441 • USA**

**Copyright 2010, Graco Inc. All Graco manufacturing locations are registered to ISO 9001.**

[www.graco.com](http://www.graco.com)

Revision N, August 2017